

# Kia, The Company

---

Congratulations! Your selection of a Kia was a wise investment. It will give you years of driving pleasure. Now that you are the owner of a Kia vehicle, you'll probably be asked a lot of questions about your vehicle and the company like “What is a Kia?”, “Who is Kia?”, “What does ‘Kia’ mean?”.

Here are some answers. First, Kia is the oldest car company in Korea. It is a company that has thousands of employees focused on building high-quality vehicles at affordable prices.

The first syllable, **Ki**, in the word “Kia” means “to arise from to the world” or “to come up out of to the world.” The second syllable, **a**, means “Asia.” So, the word **Kia**, means “to arise from” or “to come up out of Asia to the world.”

*Drive safely and enjoy your Kia!*

FarmaSOS.com

# Foreword

---

Thank you for choosing a Kia vehicle.

When you require service, remember that your dealer knows your vehicle best. Your dealer has factory-trained technicians, recommended special tools, genuine Kia replacement parts and is dedicated to your complete satisfaction.

Because subsequent owners require this important information as well, this publication should remain with the vehicle if it is sold.

This manual will familiarize you with operational, maintenance and safety information about your new vehicle. It is supplemented by a Warranty & Consumer Information manual that provides important information on all warranties regarding your vehicle. If your vehicle is equipped with an audio system, you will also receive a Kia Integrated Audio System Manual. We urge you to read these manuals carefully.

Kia offers a great variety of options, components and features for its various models.

Therefore, the equipment described in this manual, along with the various illustrations, may not all be applicable to your particular vehicle. The information and specifications provided in this manual were accurate at the time of printing. Kia reserves the right to discontinue or change specifications or design at any time without notice and without incurring any obligation. If you have questions, always check with your Kia Dealer.

We assure you of our continuing interest in your motoring pleasure and satisfaction in your Kia vehicle.

© 2005 Kia Motors America, Inc.

All rights reserved. May not be reproduced or translated in whole or in part without the written consent of Kia Motors America, Inc.

Printed in Korea

---

## TABLE OF CONTENTS

<b>INTRODUCTION</b>	<b>1</b>
<b>YOUR VEHICLE AT A GLANCE</b>	<b>2</b>
<b>KNOWING YOUR VEHICLE</b>	<b>3</b>
<b>DRIVING YOUR VEHICLE</b>	<b>4</b>
<b>DRIVING TIPS</b>	<b>5</b>
<b>IN CASE OF AN EMERGENCY</b>	<b>6</b>
<b>MAINTENANCE</b>	<b>7</b>
<b>SPECIFICATIONS</b>	<b>8</b>
<b>CONSUMER ASSISTANCE</b>	<b>9</b>
<b>INDEX</b>	<b>10</b>

---

## INTRODUCTION

How To Use This Manual .....	1-2
Vehicle Break-In Process .....	1-3

امداد خودرو فارما

تلفن شبانه روزی: ۰۲۱-۸۸۸۶۲۰۸۵

FarmaSOS.com

# Introduction

---

## HOW TO USE THIS MANUAL

We want to help you get the greatest possible driving pleasure from your vehicle. Your Owner's Manual can assist you in many ways. **For your safety and the safety of your passengers, we strongly urge that you read the entire manual. In order to avoid death or injury, please review the WARNING and CAUTION sections contained throughout the manual. The WARNING and CAUTION sections are easily recognized by their special markings listed on this page.**

Illustrations complement the words in this manual to best explain how to enjoy your vehicle. By reading your manual, you will learn about features, important safety information, and driving under various road conditions.

The general layout of the manual is provided in the Table of Contents. In addition, an alphabetical index located at the back of the manual has been provided for you reference.

Sections: This manual has nine sections plus an index. Each section begins with a brief list of contents to provide you with an overview of what is contained in that section.

You will find various WARNING's, CAUTION's, and NOTICE's in this manual. These WARNING's, CAUTION's and NOTICE's are provided to enhance your safety and continued satisfaction with your Kia vehicle. You should carefully read and follow ALL procedures and recommendations provided in these WARNING's, CAUTION's and NOTICE's.

### **WARNING**

**A WARNING indicates a situation in which severe bodily injury or death is likely if the warning is ignored.**

### **CAUTION**

*A CAUTION indicates a situation in which injury, could result if the caution is ignored.*

### **NOTICE**

A NOTICE indicates a situation in which damage to your vehicle could result if the notice is ignored.

---

## VEHICLE BREAK-IN PROCESS

No special break-in period is needed. By following a few simple precautions for the first 600 miles (1 000 km) you may add to the performance, economy and life of your vehicle.

- Do not race the engine.
- Do not maintain a single speed for long periods of time, either fast or slow. Varying engine speed is needed to properly break in the engine.
- Avoid hard stops, except in emergencies, to allow the brakes to seat properly.
- Avoid full-throttle starts.

تلفن شبانه روزی: ۰۲۱-۸۸۸۶۲۰۸۵

FarmaSOS.com

---

## YOUR VEHICLE AT A GLANCE

Interior and Exterior Overview .....	2-2
Instrument Panel Overview .....	2-3

امداد خودرو فارما

تلفن شبانه روزی: ۰۲۱-۸۸۸۶۲۰۸۵

FarmaSOS.com

# Your Vehicle At A Glance

## INTERIOR AND EXTERIOR OVERVIEW

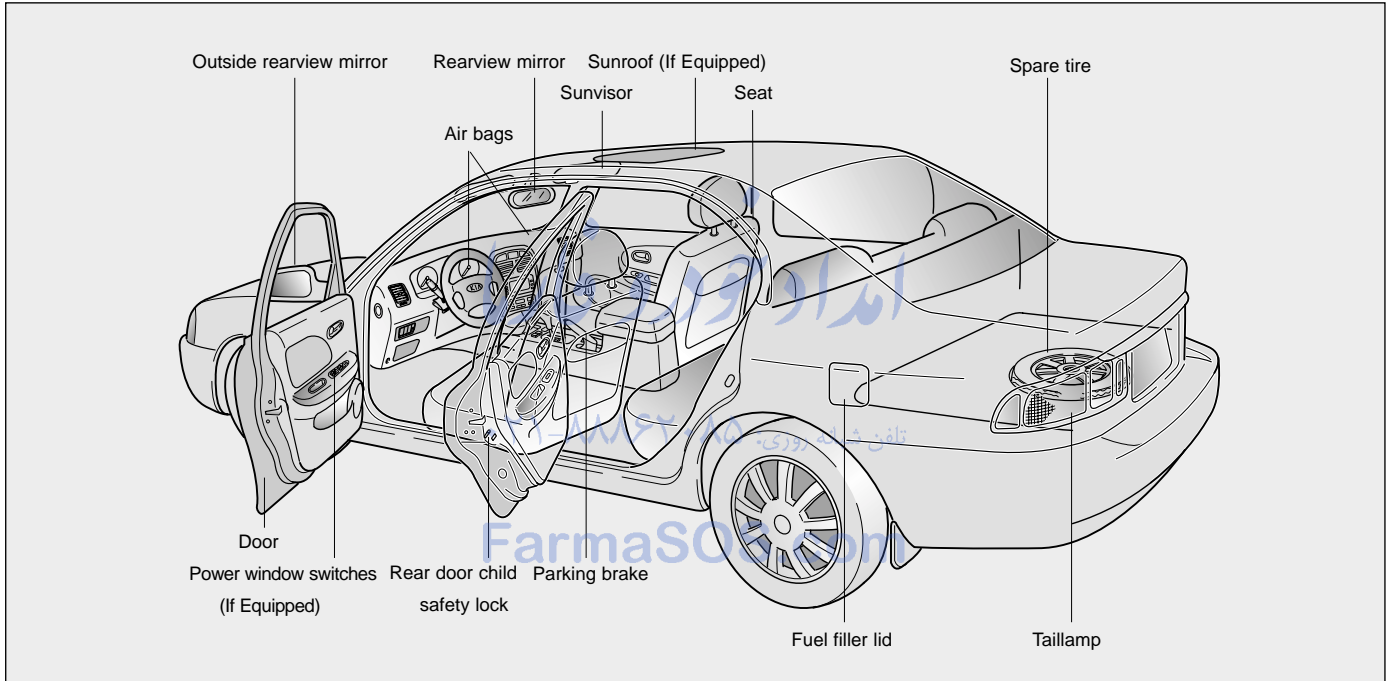

MMSA2001

# INSTRUMENT PANEL OVERVIEW

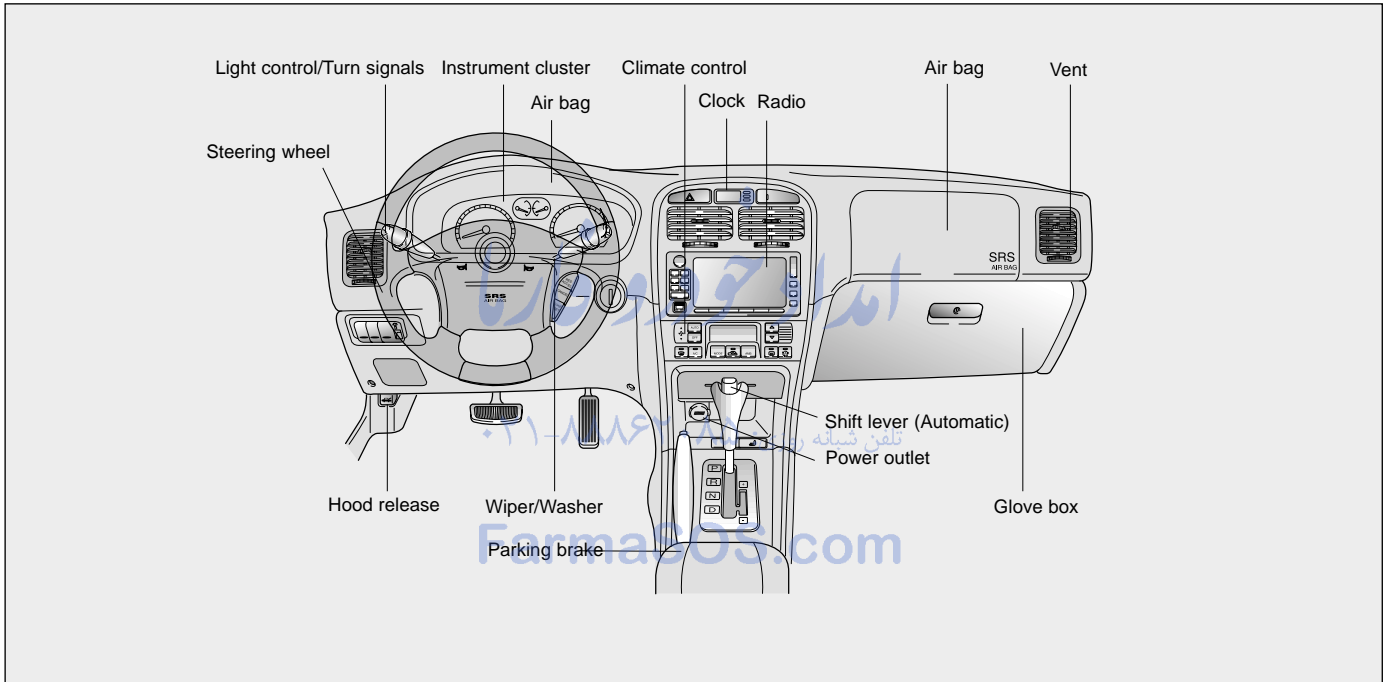

MMSA2002

---

## KNOWING YOUR VEHICLE

Keys . . . . .	3-2
Keyless Entry System . . . . .	3-3
Door Locks . . . . .	3-5
Windows . . . . .	3-9
Front Seat . . . . .	3-12
Rear Seat . . . . .	3-22
Safety Belts . . . . .	3-25
Air Bag - Supplemental Restraint System . . . . .	3-56
Trunk Lid . . . . .	3-68
Hood . . . . .	3-71
Fuel Filler Lid . . . . .	3-73
Steering Wheel . . . . .	3-76
Mirrors . . . . .	3-78
Interior Lights . . . . .	3-82
Cup Holder . . . . .	3-84
Sunglass Holder . . . . .	3-85
Console Storage Compartment . . . . .	3-85
Sunroof . . . . .	3-87
Antenna . . . . .	3-90
Luggage Net . . . . .	3-93

# Knowing Your Vehicle

## KEYS

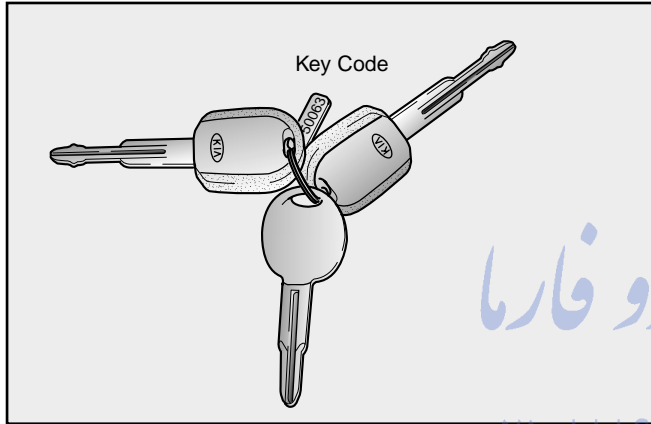

MMSA3070

The key code number is stamped on the plate attached to your key set. Should you lose your keys, this number will enable an authorized Kia dealer to duplicate your keys easily. Remove this plate from the key ring and store it in a safe place. Also, record the code number and keep it in a safe and handy place, but not in the vehicle.

### **⚠ WARNING - Ignition Key**

Leaving children unattended in a vehicle with the ignition key is dangerous even if the key is not in the ignition. Children could place the key in the ignition and operate the power windows or other controls, leading to a serious accident. Never leave a child alone in the vehicle, with or without keys.

Leaving your sub key with a parking attendant will ensure that your vehicle's trunk, trunk lid release, glove box compartment and rear trunk access may not be unlocked in your absence.

### **⚠ CAUTION**

*Use only Kia original parts for the ignition key in your vehicle. If an aftermarket key is used, the ignition switch may not return to ON after START. If this happens, the starter will continue to operate causing damage to the starter motor and possible fire due to excessive current in the wiring.*



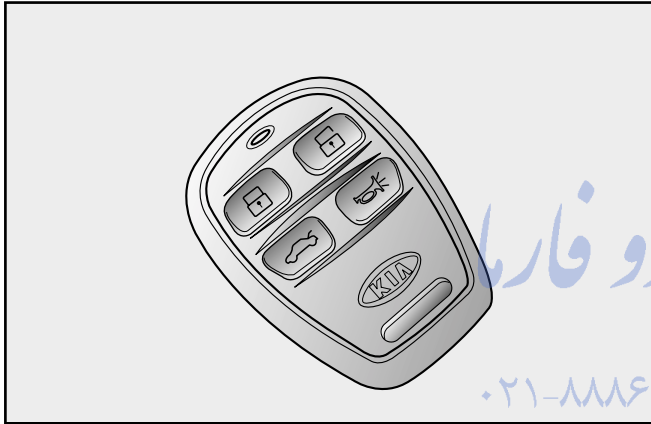

## KEYLESS ENTRY SYSTEM (IF EQUIPPED)



MMSA3067

You can also lock or unlock the door and open the trunk from outside with the keyless transmitter.

-  To lock the door, press this button once. (Hazard flasher lights are turned on once for about one second.)

-  To unlock the driver's door, press this button once. (Hazard flasher lights flash twice.) To unlock the other doors, press this button twice within three seconds.
-  To open the trunk, press this button.
-  If you depress the panic button () on the transmitter, the horn will sound and hazard lamp will flash.

The transmitter will not work if any of the following occur:

- Ignition key is in the ignition switch.
- The transmitter battery is discharged.
- The operational distance 15 feet (5 meters) is exceeded.
- The weather is very cold or when there are other vehicles or objects around the vehicle.

When the transmitter does not work correctly, open and close the door with the ignition key. If you have a problem with the transmitter, contact an Authorized Kia Dealer.

# Knowing Your Vehicle

This device complies with Part 15 of the FCC rules. Operation is subject to the following two conditions:

1. This device may not cause harmful interference, and
2. This device must accept any interference received, including interference that may cause undesired operation.

## **⚠ WARNING**

**Changes or modifications not expressly approved by the party responsible for compliance could void the user's authority to operate the equipment.**

## **Battery replacement**

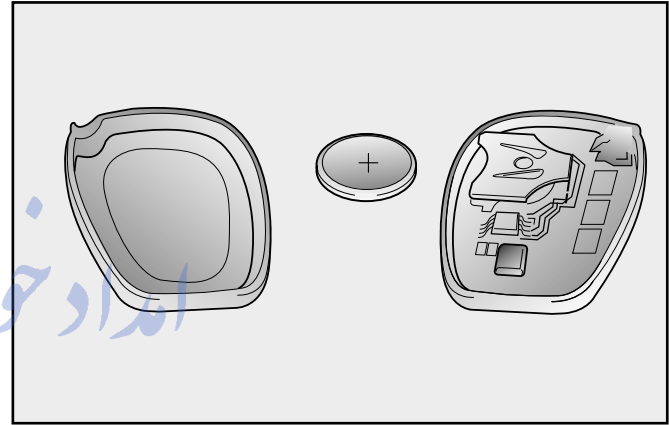

MMSA3068

Transmitter uses a 3 volt lithium battery which will normally last for several years.

When replacement is necessary, use the following procedure.

1. Using a screwdriver, loosen the screw on the backside of the transmitter then use a thin tool to pry open the transmitter.
2. Disassemble the transmitter and remove the battery.
3. Make sure the battery positive “(+)” symbol faces up as indicated in the illustration.

### **CAUTION**

*Using the wrong battery can cause the transmitter to malfunction. Be sure to use the correct battery.*

## **DOOR LOCKS**

### **Automatic Door Locks**

#### **Operating Door Locks - With the Key**

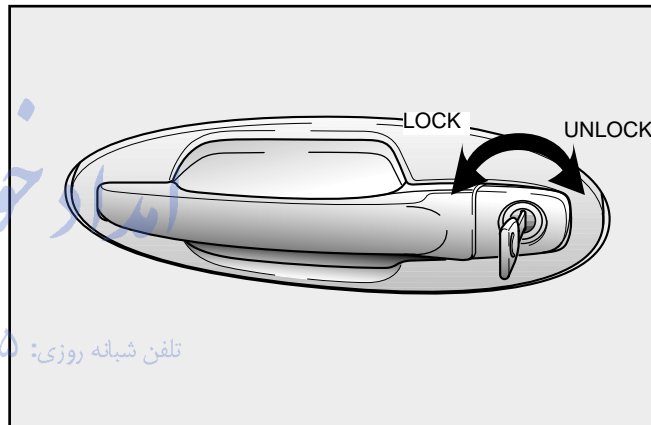

MMSA3001

- Both front doors can be locked and unlocked with the key.
- Turn the key to the left to lock and to the right to unlock the door.
- Once a door is unlocked, it may be opened by pulling the door handle.

# Knowing Your Vehicle

## Operating Door Locks - Without the Key

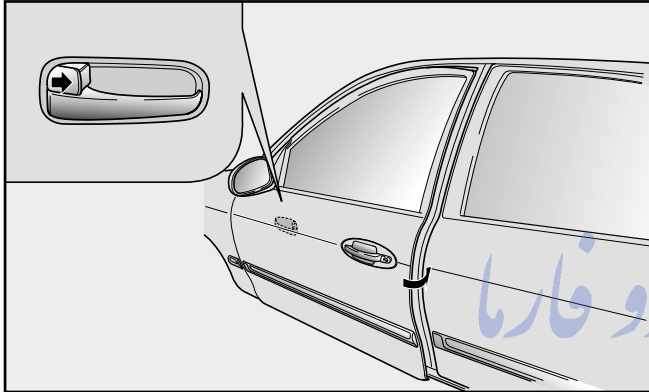

MMSA3002

To lock a door without the key, push the inside door lock button to the “LOCK” position and close the door.

### \* NOTICE

Always remove the ignition key, engage the parking brake, close all windows and lock all doors when leaving your vehicle unattended.

## Two Turn Unlock System

At the driver's door, if you would unlock the other doors, you must turn the key to the right twice within 3 seconds, but all doors can be locked by turn the key once.

3-6

## Operating Door Locks From Inside the Vehicle

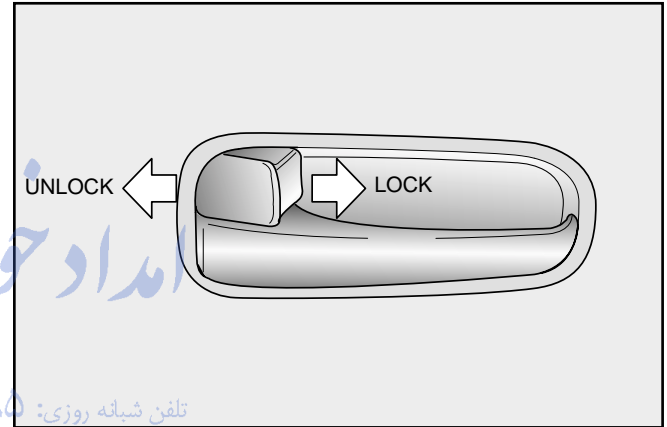

MMSA3003

- To lock a door, push the door lock button to the “LOCK” position.
- To unlock a door, push the door lock button to the “UNLOCK” position.
- To open a door, pull the door handle outward.

## Central door locks (if equipped)

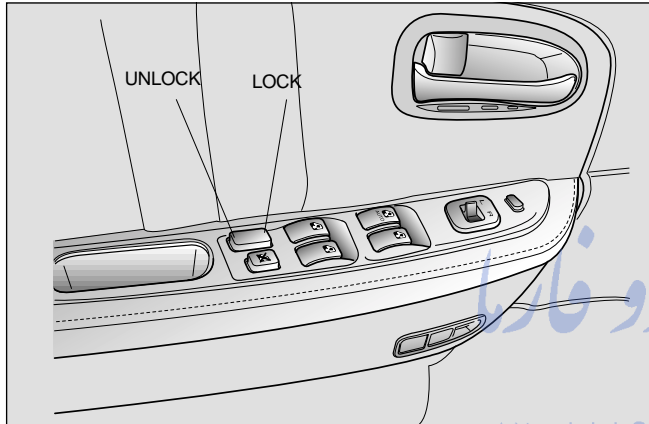

The central door locking switch is located on the driver's arm rest. It is operated by depressing the door lock switch. If any door is open when the switch is depressed, the door will remain locked when closed.

### \* NOTICE

- When pushing the front portion of the driver's door lock switch, all vehicle doors will lock.
- When pushing the rear portion of the switch, all vehicle doors will unlock.

### ⚠ WARNING

Leaving your vehicle unlocked can invite theft or possible harm to you or others from someone hiding in your vehicle while you are gone. Always remove the ignition key, engage the parking brake, close all windows and lock all doors when leaving your vehicle unattended.

# Knowing Your Vehicle

The door ajar warning light will illuminate when a door is not fully closed. Close the door completely and the light will go out.

## **⚠️ WARNING - Unattended Children**

An enclosed vehicle can become extremely hot, causing death or severe injury to unattended children or animals who cannot escape the vehicle. Furthermore, children might operate features of the vehicle that could injure them, or they could encounter other harm, possibly from someone gaining entry to the vehicle. Never leave children or animals unattended in your vehicle.

## **⚠️ CAUTION**

The doors should always be fully closed and locked while the vehicle is in motion to prevent accidental opening of the door. Locked doors will also discourage potential intruders when the vehicle stops or slows.

## Rear Door Child Safety Lock

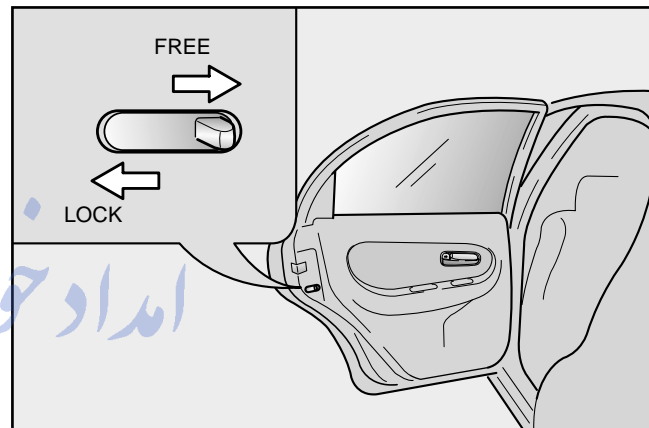

MMSA3005

The child safety lock is provided to help prevent children from accidentally opening the rear doors from inside the vehicle.

- To lock a rear door so that it cannot be opened from the inside, push the child safety lock located on the rear edge of the door to the “LOCK” position (toward rear of vehicle) before closing the door.
- To open a rear door while the child safety lock is engaged, push the door lock knob to the “UNLOCK” position (red mark is visible) then pull the outside door handle.

### **⚠ WARNING - Rear Door Locks**

If children accidentally open the rear doors while the vehicle is in motion, the child could fall out and be seriously injured. To prevent a child from opening the rear doors from the inside, the rear door safety locks should be used whenever children are in the vehicle.

## **WINDOWS**

### ***Power Windows (if equipped)***

The ignition switch must be in the ON position for power windows to operate. Each door has a power window switch that controls that door's window. However, the driver has a power window switch which can block the operation of the passenger windows.

### **\* NOTICE**

To prevent the possibility of damage to the power window system, do not open or close more than two windows at the same time. This will also ensure the longevity of the fuse.

### **⚠ WARNING - Windows**

- Do not allow children to play with the power windows. They may seriously injure themselves or others.
- Always double check to make sure all arms, hands, and other obstructions are safely out of the way before closing a window.

# Knowing Your Vehicle

## Driver's Door Power Window Controls

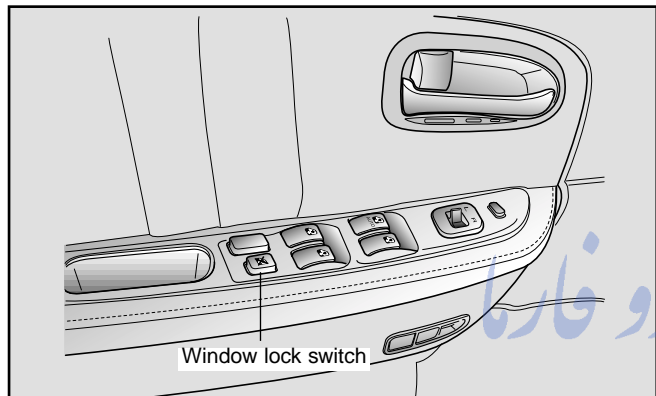

The driver's door has a master power window switch that controls all the windows in the vehicle. The ignition switch must be in the ON position for power windows to operate. To open a window, press down on the front portion of the corresponding switch. To close a window, pull up on the front portion of the corresponding power window switch.

## Power window timer (if equipped)

The power windows can be operated for approximately 30 seconds after the ignition key is removed or turned to the ACC or LOCK position. However, if the front doors are opened, the power windows cannot be operated even within the 30 seconds after the ignition key removal.

## Power Window Lock Switch Feature

The driver can lock the power window switches on all passenger doors by depressing the left side (flat portion) of the "WINDOW LOCK" switch located on the driver's door to ON (flat side down). When the power window lock switch is ON, the driver's master control can not operate the passenger door power windows either.

### **⚠ WARNING - Power Windows**

**Keep the power window lock switch in the driver's door in the ON/"LOCK" (left side/flat portion of switch down) position, except when someone is operating a passenger door window. Serious injury can result (especially to children) from unintentional window operation.**

## \* NOTICE

If you notice buffeting and pulsation (wind shock) with either side window open, you should open the opposite window slightly to reduce the condition.

## Passenger Doors Power Window Controls

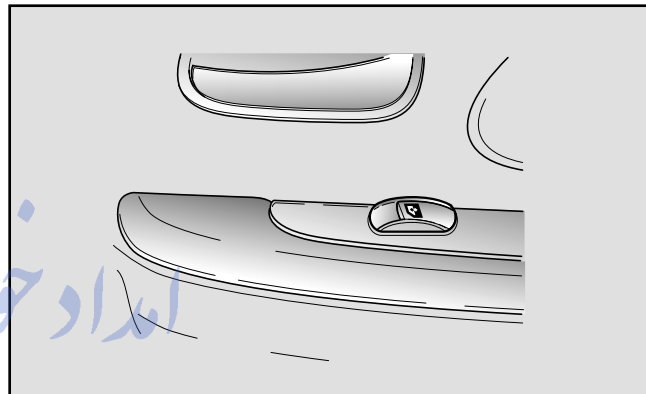

MMSA3006

To open a window, press down on the front portion of the power window switch. To close a window, pull up on the front portion of the power window switch.

## \* NOTICE

The driver's door window "LOCK" switch must be in the OFF position (not depressed) to operate the passenger door windows.

# Knowing Your Vehicle

## FRONT SEAT

### **⚠️ WARNING - Driver's Seat**

- Adjusting the driver's seat with the vehicle in motion could cause loss of control and a serious accident.
- Do not allow anything to interfere with the normal position of the seatback. Storing items against a seatback or in any other way interfering with proper locking of a seatback could result in serious or fatal injury in a sudden stop or collision.
- Always drive and ride with your seatback upright and the lap portion of the safety belt, or lap belt, snug and low across the hips. This position puts your safety belts in the best position to protect you in case of an accident.

(Continued)

(Continued)

- The National Highway Traffic Safety Administration (NHTSA) recommends that the driver sit at least 10 inches (250 mm) away from the steering wheel to avoid the risk of serious injury or death due to the deployment of the driver's airbag.

## Front Seat Adjustment - Manual

### Moving the Front Seat Forward and Backward

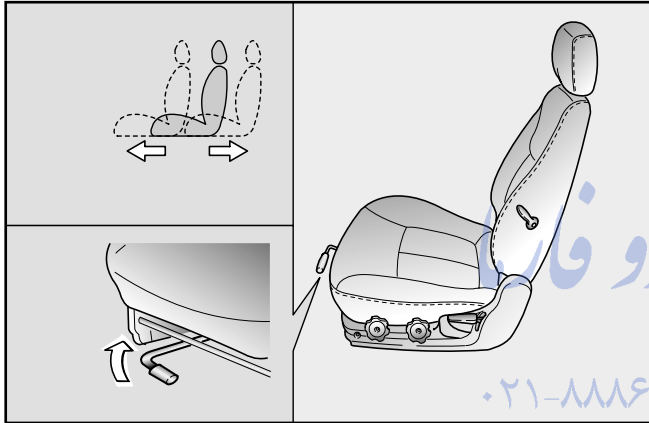

MMSA3007

To move the seat forward or backward, pull up on the lever under the front edge of the seat cushion, slide the seat to the desired position, and release the lever. To ensure the seat is locked in position, check for any seat movement.

## **⚠ WARNING**

Loose objects in the driver's foot area could interfere with the operation of the foot pedals, possibly causing an accident. Loose objects might interfere with the seat slide mechanism. Do not place anything under the front seats.

تلفن شبانه روزی: ۰۲۱-۸۸۶۲۰۸۵

FannaSOS.com

# Knowing Your Vehicle

## Adjusting the Front Seatback Recliner

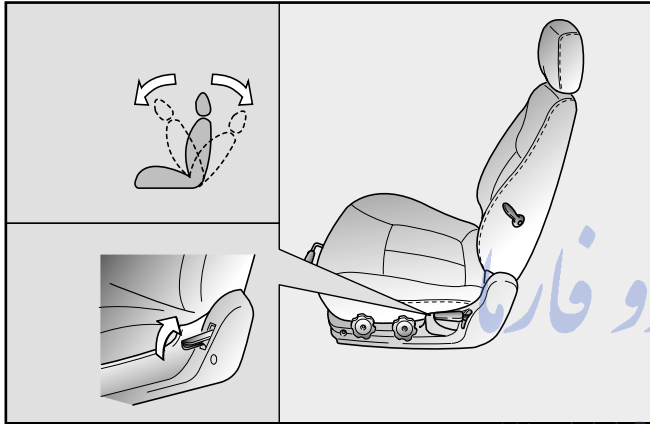

To change the seatback angle, lean forward slightly and raise the lever located on the outer portion of the seat. Slowly and carefully lean back to the desired angle and release the lever. After adjustment, make sure that the lever has returned to its original locked position.

### **⚠ WARNING - Front Seat**

Riding in a vehicle with a front seatback reclined could lead to serious or fatal injury in an accident. If a front seat is reclined, the occupant's hips may slide under the lap portion of the safety belt applying great force to the unprotected abdomen. Internal injuries could result. Keep the seatbacks in a comfortably upright position whenever the vehicle is in motion.

## Adjusting the height of front seat cushion (if equipped)

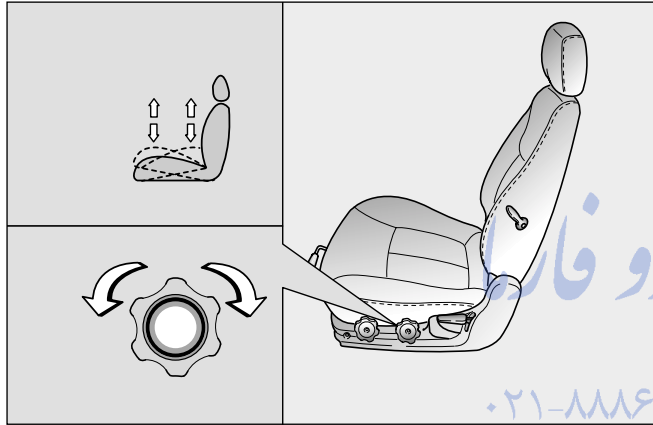

MMSA3009

To change the height (front portion) of the seat cushion, rotate the knob located on the outside of the seat cushion.

- To lower the seat cushion, rotate the knob toward the front of the vehicle.
- To raise the seat cushion, rotate the knob toward the rear of the vehicle.

To change the height (rear portion) of the seat cushion, rotate the knob located on the outside of the seat cushion.

- To lower the seat cushion, rotate the knob toward the front of the vehicle.
- To raise the seat cushion, rotate the knob toward the rear of the vehicle.

# Knowing Your Vehicle

## Lumbar Support (Driver's Seat Only)

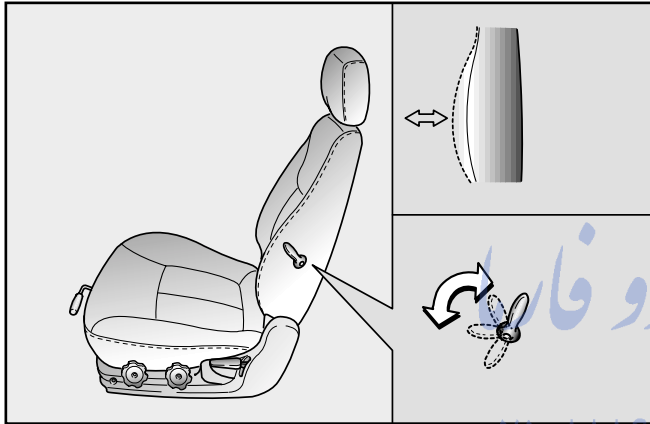

You can adjust the lumbar support by moving the lever on the right side of the driver's seatback. Pivoting the lever toward the front of the vehicle increases the lumbar support. Pivoting the lever toward the rear of the vehicle decreases the lumbar support.

## Front Seat Adjustment - Power (if equipped)

The driver's seat can be adjusted by using the control knob on the left side of the seat. Before driving, adjust the seat to the proper position so as to easily control the steering wheel, pedals and switches on the instrument panel.

### **CAUTION**

*Do not operate two knobs at the same time.*

## **⚠️ WARNING - Driver's Seat**

- **Never attempt to adjust seat while the vehicle is moving. This could result in loss of control, and an accident causing death, serious injury, or property damage.**
- **In order to avoid unnecessary airbag injuries including the possibility of severe injury or death, always sit as far back as possible from the steering wheel while still being able to maintain comfortable control of your vehicle.**
- **The National Highway Traffic Safety Administration (NHTSA) recommends that the driver sit at least 10 inches (250 mm) away from the steering wheel to avoid the risk of serious injury or death due to the deployment of the driver's airbag.**
- **The power seats are operable with the ignition OFF. Therefore, children should never be left unattended in the car.**

## **Moving the front seat forward and backward**

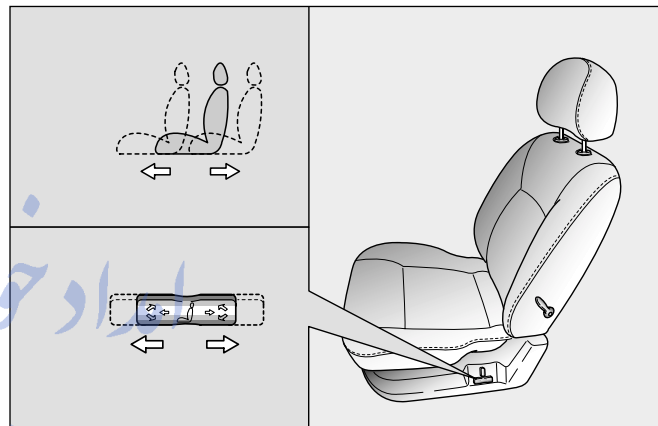

MMSA3011

تلفن شبانه روزی: ۰۸۵ ۰۸۶۲ ۰۸۵  
Push the control knob forward or backward to move the seat to the desired position. Release the knob and the seat will lock in that position.

1. Reclining Control Knob
2. Sliding and Height Adjusting Control Knob

# Knowing Your Vehicle

## \* NOTICE

Prior to operating the vehicle, ensure the seat is locked securely by trying to move the seat forward or backward without using the control knob. If the seat moves, it is not locked properly.

## Adjusting the front seatback recliner

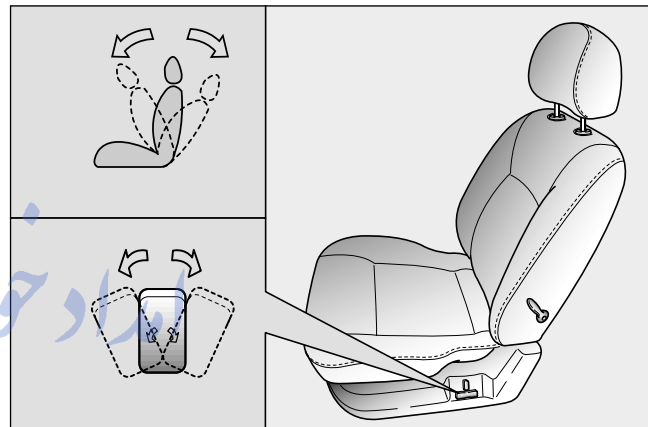

MMSA3012

Rotate the upper portion of the control knob forward or backward to recline the seatback to the desired position. Release the control knob and the seatback will lock in position.

## Adjusting the height of front seat cushion

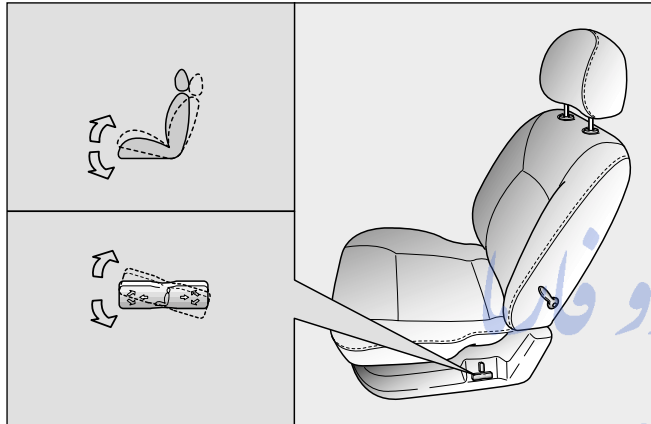

MMSA3013

### Front height of front seat cushion

Move the front portion of the control knob up to raise or down to lower the front part of the seat cushion.

## Rear height of front seat cushion

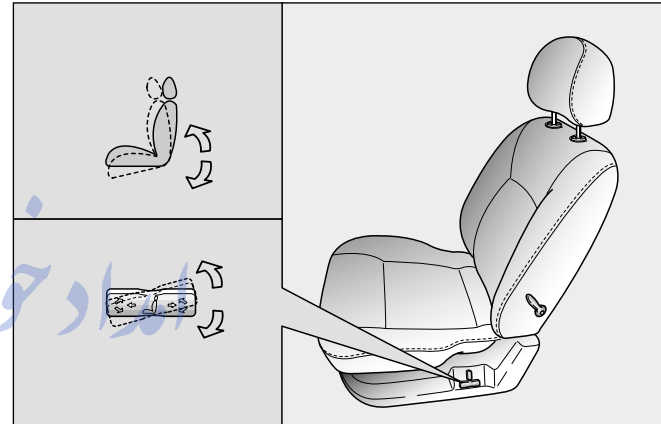

MMSA3014

Move the rear portion of the control knob up to raise or down to lower the rear part of the seat cushion.

# Knowing Your Vehicle

## Height of front seat cushion

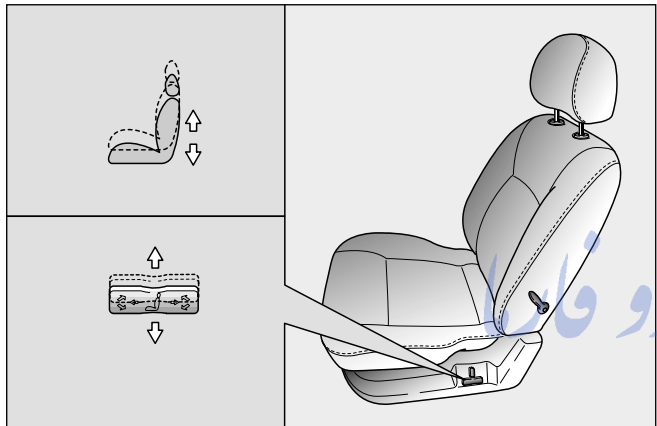

To raise or lower the seat cushion totally, pull up and push down on the center of the corresponding switch.

### **⚠ WARNING**

To minimize the risk of possible severe personal injury in the event of a collision, both the driver's and passenger's seatbacks should be in a normal seating position while the car is in motion. The protection provided by the vehicle's restraint system may be reduced significantly when the seatbacks are reclined. All parts of the restraint system are designed to absorb energy in an accident and this can best be accomplished if the seatback is in a normal seating position and the seatbelt is in close proximity to the occupant.

## Headrest

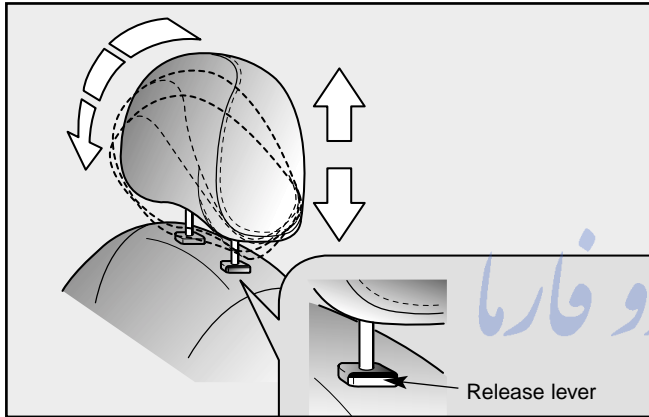

To raise the headrest, simply pull it up to the desired position. To lower the headrest, press the release lever on the left side grommet, while pushing the headrest down to the desired position. To remove the headrest, raise it as far as it can go then press the release lever while pulling upward.

The headrest may be adjusted forward to three positions by pulling it forward. To adjust the headrest backwards, pull it forward and release it.

### **⚠ WARNING - Headrests**

- To reduce the risk of head and neck injuries, don't operate the vehicle with the headrest removed or improperly positioned.
- For best protection, adjust the headrest so its center is as high as your ears.
- Do not adjust the driver's headrest while driving.

# Knowing Your Vehicle

## REAR SEAT

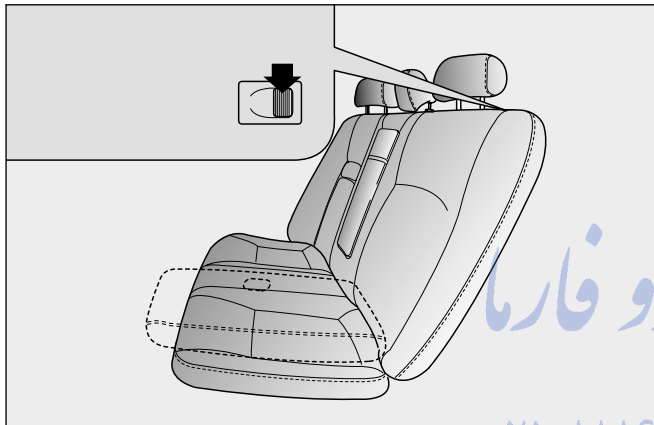

When you return the seatback to its upright position, reposition the rear safety belts so that they can be used by rear seat passengers.

### **⚠ WARNING - Cargo**

**Cargo should always be secured to prevent it from shifting and causing injury to the vehicle occupants.**

The rear seatbacks fold forward to provide additional cargo space and to provide access to the trunk area.

- To fold the rear seatback(s) down, press the unlock button located on top of the seatbacks, then fold the seatback forward and down.
- To raise the seatback, lift and push it firmly until it clicks into place.

## **CAUTION**

*Do not remove the floor carpet in your vehicle. Emission control system components cause high exhaust temperatures under the floor.*

## **\* NOTICE**

When returning the rear seat backs to the upright position, remember to return the rear shoulder belts to their proper position. Routing the safety belt webbing through the rear safety belt guides will help keep the belts from being trapped behind or under the seats.

## **Rear seatback lock**

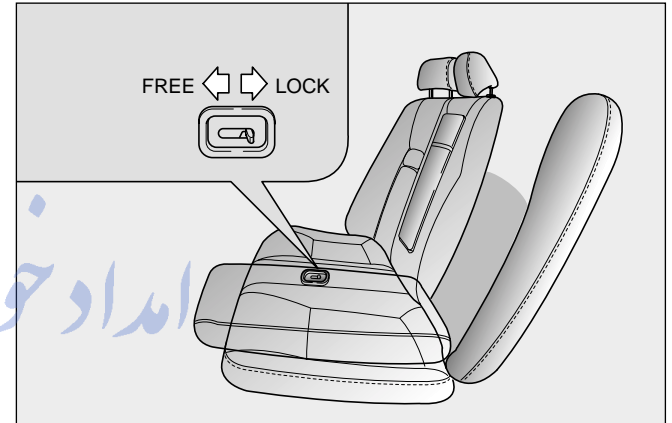

When the rear seatback lock lever (located on the backside of the rear seatback) is in the "LOCK" position, it is not possible to fold the rear seatback down by using the release lock lever. Should this happen, open the trunk and move the lock lever to the "FREE" position and use the release lock lever located on the top of the seatback to fold the rear seatback down. The rear seatback lock lever is designed to provide protection from unauthorized entry into the trunk.

# Knowing Your Vehicle

---

## Rear Seat Armrest

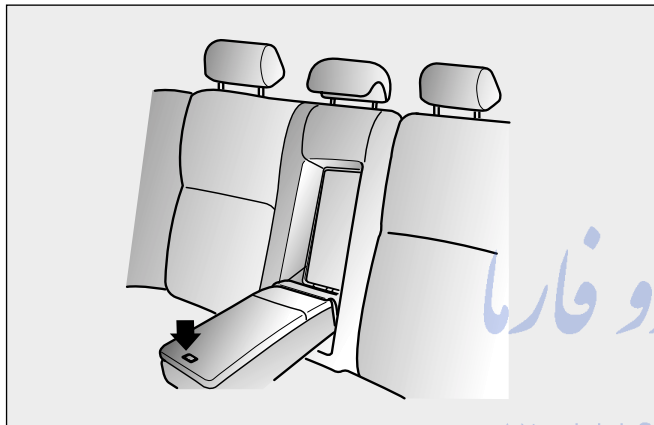

MMSA3019

This armrest is located in the center of the rear seatback. Pull the armrest down using the strap provided on the armrest.

To open the armrest cover, press the button on the top of the cover and pull the cover up. Inside you will find cup holders and a storage compartment.

## SAFETY BELTS

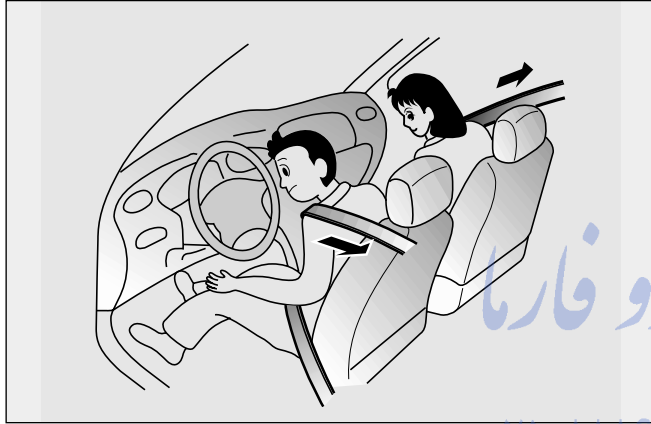

### **Pre-tensioner Seat Belt**

Your vehicle is equipped with driver's and front passenger's pre-tensioner seat belts. The purpose of the pre-tensioner is to make sure that the seat belts fit tightly against the occupant's body in certain frontal collisions.

The pre-tensioner seat belts can be activated alone or, together with the airbags, where the frontal collision is severe enough.

The pre-tensioner seat belt operates in the same way as an Emergency Locking Retractor (ELR) type of seat belt. When the vehicle stops suddenly, or if the occupant tries to lean forward too quickly, the seat belt retractor will lock into position. However, in certain frontal collisions, the pretensioner will activate and pull the seat belt into tighter contact against the occupant's body.

تلفن شبانه روزی: ۰۲۱-۸۸۳۲۰۸۵

FarmaSOS.com

# Knowing Your Vehicle

The seat belt pre-tensioner system consists mainly of the following components. Their locations are shown in the illustration.

1. SRS airbag warning light.
2. Seatbelt pre-tensioner assembly.
3. SRS control module.

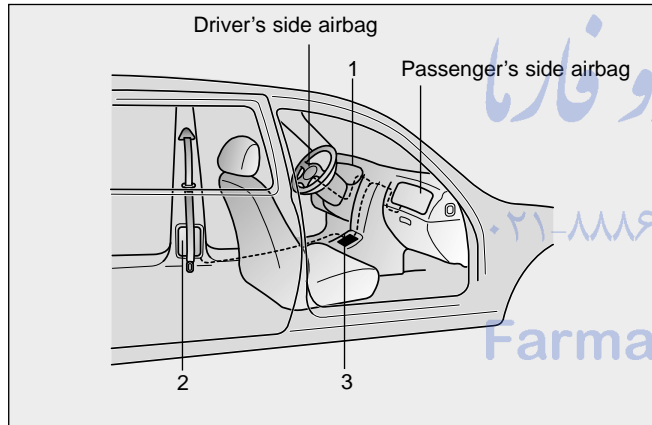

MMSA3021

## **⚠ WARNING**

**To obtain maximum benefit from a pre-tensioner seat belt:**

- **The seat belt must be worn correctly.**
- **The seat belt must be adjusted to the correct position.**

امداد خودرو فارما

تلفن شبانه روزی: ۰۲۱-۸۸۶۲۰۸۵

FarmaSOS.com

## \* NOTICE

- Both the driver's and front passenger's pretensioner seat belts will be activated in certain frontal collisions. The pretensioner seat belts can be activated alone or, where the frontal collision is severe enough, together with the airbags. The pretensioners will be activated under these conditions even if the seat belts are not being worn at the time of the collision.
- When the pretensioner seat belts are activated, a loud noise may be heard and fine dust, which may appear to be smoke, may be visible in the passenger compartment and are not toxic.
- Although it is harmless, the fine dust may cause skin irritation and should not be breathed for prolonged periods. Wash your hands and face thoroughly after an accident in which the airbags and/or pretensioner seat belts were activated.

## ⚠ CAUTION

- *Because the sensor that activates the SRS airbag is connected with pretensioner seat belt, the SRS airbag warning light on the instrument panel will blink for approximately 6 seconds after the ignition key has been turned to the "ON" or "ACC" positions, then it should go off.*
- *If the pretensioner seat belt is not working properly, this warning light will illuminate even if there is no malfunction of SRS airbag system. If the SRS airbag warning light does not illuminate when the ignition key is turned to "ON" or "ACC", or if it remains illuminated after blinking for approximately 6 seconds, or if it illuminates while the vehicle is being driven, please have an authorized Kia dealer inspect the pretensioner seat belt or SRS airbag system as soon as possible.*

# Knowing Your Vehicle

## **WARNING**

- Pre-tensioners are designed to operate once. After activation, pre-tensioner seat belts must be replaced. All seat belts, of any type, should always be replaced after they have been worn during a collision.
- The Pre-tensioner seat belt assembly mechanisms become hot during activation. Do not touch the pre-tensioner seat belt assemblies for several minutes after they have been activated.
- Do not attempt to inspect or replace the pre-tensioner seat belts yourself. This must be done by an authorized Kia dealer.
- Do not strike the pre-tensioner seat belt assemblies.

(Continued)

(Continued)

- Do not attempt to service or repair the pre-tensioner seat belt system in any manner.
- Improper handling of the pre-tensioner seat belt assemblies, and failure to heed the warnings not to strike, modify, inspect, place, service or repair the pre-tensioner seat belt assemblies may lead to improper operation or inadvertent activation causing serious injury.  
Always wear the seat belts when driving or riding in a motor vehicle.

## ***Safety Belt Restraint System***

### **⚠️ WARNING - Safety Belts**

**To minimize the risk of serious or fatal injury in an accident, the driver and all passengers should use the appropriate safety restraints for their age and size. The presence of airbags does not change the need to be properly restrained by a safety belt or size-appropriate child restraint. In fact, airbags can work properly when passengers are correctly restrained in the vehicle. Be sure you are familiar with the information in this section, including the information on infant and child restraints. Read the safety warnings on the sun visors of your vehicle also.**

We strongly recommend that the driver and all passengers be properly restrained at all times by using the safety belts provided with the vehicle. Proper use of the safety belts decreases the risk of severe injury or death in accidents or sudden stops. In most states, and in Canada, the law requires their use.

All seats, except the center rear seat, have lap/shoulder belts. The center rear seat has a lap belt.

Inertial locks in the safety belt retractors allow all of the lap/shoulder safety belts to remain unlocked during normal vehicle operation.

تلفن شبانه روزی: ۰۸۵-۸۸۶۲۰۸۵  
FarmaSOS.com

# Knowing Your Vehicle

---

This allows the occupants some freedom of movement and increased comfort while using the safety belts. If a force is applied to the vehicle, such as a strong stop, a sharp turn, or a collision, the safety belt retractors will automatically lock the safety belts.

Since the inertial locks do not require a collision to lock up, you may become aware of the safety belts locking while braking or going around sharp corners.

Whenever possible, use the center rear seat position to install your child restraint system. The center rear seat safety belt does not have an inertial lock, so it is always in a locked condition. If the center seat is unavailable, a child restraint system may be installed in an outboard rear seat position. Never install a rear-facing infant seat in the front passenger position, as an inflating airbag could cause serious or fatal injury to a child in that position.

The rear outboard safety belts use a special auto-lock feature designed to allow a child restraint to be used in these positions without an added locking clip. They normally lock only under extreme or emergency conditions (emergency lock mode). However they can be adjusted so that they remain fixed and locked when a child restraint system is placed in these positions. (Use this auto-lock mode only to secure a child restraint, never for passengers restrained by the safety belts.) Page 3-47 gives instructions on placing the safety belt in the auto lock mode.

The drivers safety belt can only operate in the emergency lock mode.

---

Safety belts provide the best restraint when:

- The seatback is upright
- The occupant is sitting upright (not slouched)
- The lap belt is snug across the hips
- The shoulder belt is snug across the chest
- The knees are straight forward

To help you remember to fasten your safety belt, a warning light will come on and a chime will sound. See Safety Belt Warning Light and Chime on page 3-34.

### **⚠ WARNING - After a Collision**

- **Lap/shoulder belt assemblies may be stretched or damaged when subjected to the stress and forces of a collision.**
- **A safety belt must be replaced if any part of the “Replace Belt” label is visible. You won’t see this label unless your restraint system has been heavily loaded in a collision. This “Replace Belt” label, is located on the front belts near the door opening. (see next page)**
- **The entire restraint system should be inspected following any collision. All belts, retractors, anchors and hardware damaged by a collision should be replaced before the vehicle is operated again.**

# Knowing Your Vehicle

## **⚠ WARNING - Cargo Area (if equipped)**

Passengers should never be allowed to ride in the cargo area of a vehicle. No safety belts are provided for the cargo area. Persons riding in the vehicle without a fastened safety belt are much more likely to suffer serious bodily injury or death during an accident.

## **⚠ WARNING - Twisted Belts**

A twisted or jammed safety belt cannot restrain you properly. If you cannot untwist or unjam the safety belt, have a qualified Kia technician repair it immediately. never drive or ride with a twisted or jammed safety belt.

## **⚠ WARNING - Belt Usage**

Safety belts must be used correctly to work properly in an accident. Each seating position in your vehicle has a specific safety belt assembly that includes a buckle and tongue designed to be used together.

For greatest effectiveness, follow these guidelines in using safety belts:

- Use the shoulder portion of the safety belt on the outside shoulder only. Never wear the shoulder portion under the arm.

(Continued)

(Continued)

- Never swing the safety belt around your neck to fit over the inside shoulder.
- Never wear the shoulder portion of the safety belt across the neck or face.
- Wear the lap portion as low as possible. Be sure that the lap belt fits snugly around the hips. never wear a lap belt or lap portion of a lap/shoulder belt over your waist; it should always go over the stronger area of your hips.
- Never use a single safety belt for more than one person.
- The front seatbacks should always remain in a comfortable, upright position when the vehicle is moving.

### **WARNING - Safety Belt Care**

- A damaged belt may not give you the protection you need in an accident.
- Inspect our safety belts periodically for excessive wear or damage. Pull out each belt fully and look for fraying, cuts, burns or other damage. Pull the safety belt out and let it retract a number of times. Make sure that the lap/shoulder belts return smoothly and easily into the retractor.
- Check the latches to make sure they latch and release without interference or delay.
- Never close the doors on any part of the lap or shoulder belt.
- Any belt not in good condition or in good working order should be promptly replaced.

# Knowing Your Vehicle

## **CAUTION**

*Never close the doors on any part of the lap or shoulder belt. It can damage the safety belt or buckle which could increase the risk of injury in case of an accident.*

## **Safety Belt Warning Light and Chime**

As a reminder to the driver and passenger, safety belt warning light will blink for approximately 6 seconds each time you turn the ignition switch ON.

If the driver's lap/shoulder belt is not fastened when the key is turned ON or if it is unfastened after the key is turned ON, the safety belt warning light blinks for approximately 6 seconds and safety belt warning chime sounds for approximately 6 seconds.

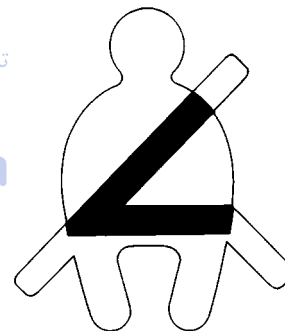

AN7B03016

تلفن شبانه روزی: ۰۲۱-۸۸۸۶۲۰۸۵

FarmaSOS.com

## **Front Lap/Shoulder Belt**

**To fasten the front lap/shoulder belt:**

1. Grasp the buckle and tongue plate.
2. Slowly pull the lap/shoulder belt out from the retractor.

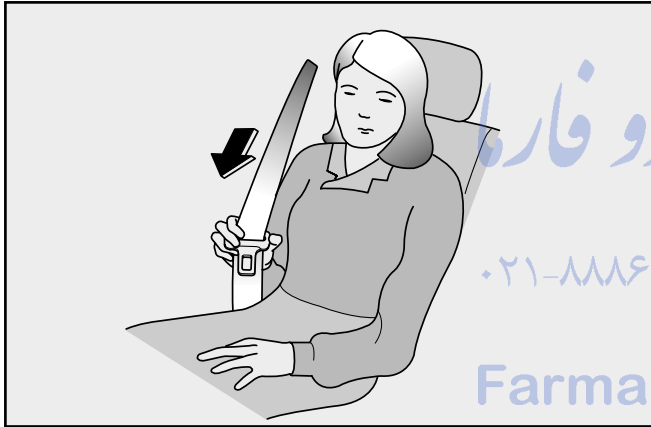

MMSA3022

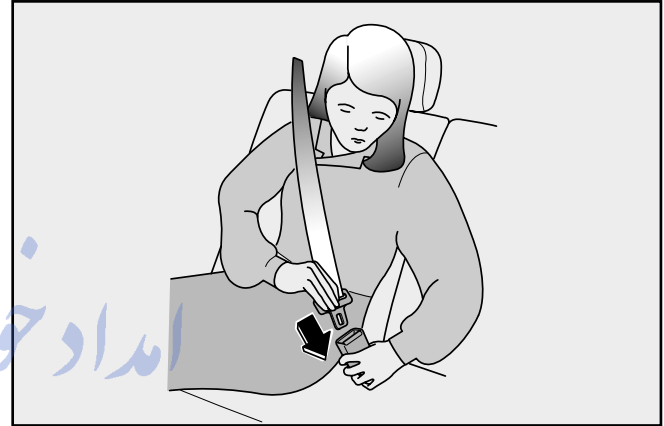

MMSA3023

3. Insert the tongue plate into the open end of the buckle until an audible “click” is heard, indicating the belt is locked in the buckle.

FarmaSOS.com

# Knowing Your Vehicle

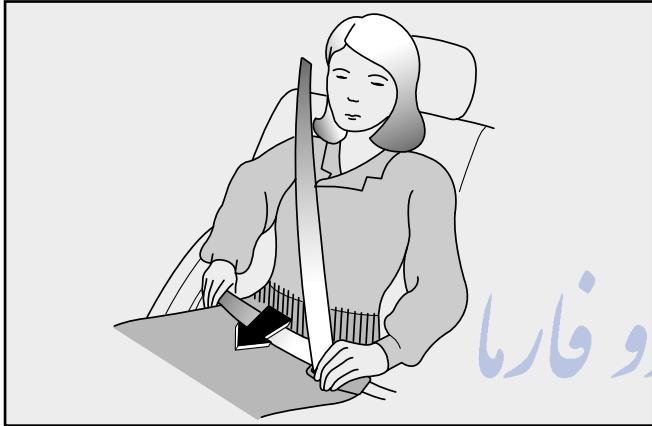

MMSA3024

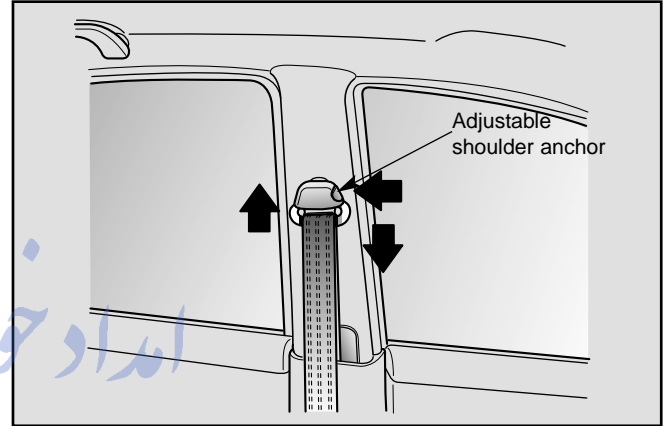

MMSA3025

4. Position the lap portion of the belt across your lap as **LOW ON THE HIPS** as possible to reduce the risk of sliding under it during an accident. Adjust the belt to a **SNUG FIT** by pulling up on the shoulder portion of the safety belt. The belt retractor is designed to take up excess webbing automatically and to maintain tension on the belt. For maximum safety, do not put any excess slack into the safety belt.

5. Adjust the shoulder anchor position to your size. To raise the anchor position, push the anchor up. To lower the anchor position, press the button and slide the anchor down. After adjustment, make sure the anchor is locked in position.



MMSA3026

### **To unfasten the front lap/shoulder belt:**

Press the release button on the buckle and allow the belt to slowly retract.

### **⚠ WARNING - Front Safety Belts**

- The front seatbacks should always remain in a comfortable, upright position while the vehicle is in motion. The safety belt system will provide the most protection with the seatbacks in an upright position.
- Never wear the shoulder portion of the safety belt under the outside arm or behind the back.
- Never wear the shoulder portion of the safety belt across the neck or face.
- Wear the lap portion of the safety belt as low as possible. Be sure the lap belt fits snugly around the hips. Never wear the lap belt over your waist.
- Make sure the safety belts are not twisted while in use.

*(Continued)*

# Knowing Your Vehicle

- Never use a single belt to restrain more than one person at a time.

**Failure to follow these warnings will increase the chance and severity of injury in an accident.**

## ***Rear safety belts***

Two kinds of belts are provided:

- Lap/shoulder belts for people who sit on the outboard sides of the rear seat.
- A lap belt for people who sit in the center of the rear seat.

## **Rear Lap/Shoulder Belt (Outboard Seats)**

**To fasten the rear lap/shoulder belt:**

1. Grasp the buckle and tongue plate.
2. Slowly pull the lap/shoulder belt out.



MMSA3022

3. Insert the tongue plate into the open end of the buckle until an audible “click” is heard, indicating the belt is locked in the buckle.



MMSA3023

4. Position the lap portion of the belt across your lap as **LOW ON THE HIPS** as possible to reduce the risk of sliding under it during an accident. Adjust the belt to a **SNUG FIT** by pulling up on the shoulder portion of the safety belt. The belt retractor is designed to take up excess webbing automatically and to maintain tension on the belt. This is for your safety. Do not put excess slack into the safety belt.

#### To unfasten:

Press the button on the buckle and allow the belt to slowly retract.

### **⚠ WARNING - Rear Lap/Shoulder Safety Belts**

- Never wear the shoulder portion of the safety belt under the outside arm or behind the back.
- Never wear the shoulder portion of the safety belt across the neck or face.
- Wear the lap portion of the safety belt as low as possible. Be sure the lap belt fits snugly around the hips. Never wear the lap belt over your waist.
- Make sure the safety belts are not twisted while in use.
- Never use a single belt to restrain more than one person at a time.

**Failure to follow these warnings could increase the chance and severity of injury in an accident.**

# Knowing Your Vehicle

## 3 Point Rear Center Belt (If equipped)

To fasten the rear center belt

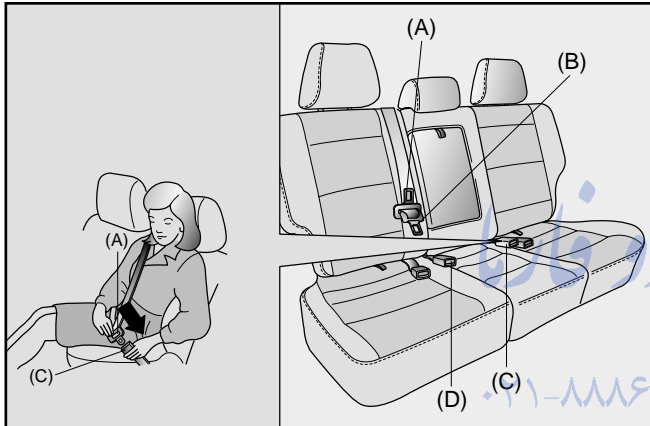

1. Slowly pull the tongue plates out from the retractor.
2. Insert the tongue plate (A) into the open end of the buckle (C) until an audible "click" is heard, indicating the latch is locked. Make sure the belt is not twisted.

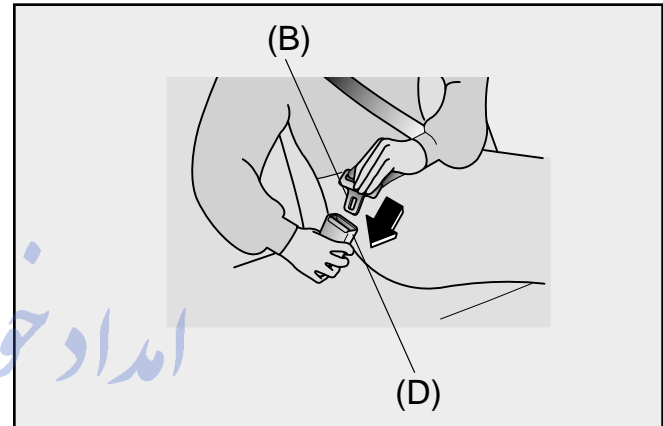

3. Pull the tongue plate (B) and insert the tongue plate into the open end of the buckle (D) until an audible "click" is heard, indicating the latch is locked. Make sure the belt is not twisted.

There will be an audible “click” when the tab locks in the buckle. The seat belt automatically adjusts to the proper length only after the lap belt is adjusted manually so that it fits snugly around your hips, if you lean forward in a slow, easy motion, the belt will extend and let you move around. If there is a sudden stop or impact, the belt will lock into position. It will also lock if you try to lean forward too quickly.

**⚠ WARNING**  
When using the rear seat center belt, you must lock all tongue plates and buckles. If any tongue plate or buckle is not locked, it will increase the chance of injury in the event of collision.

### To unfasten the rear center belt

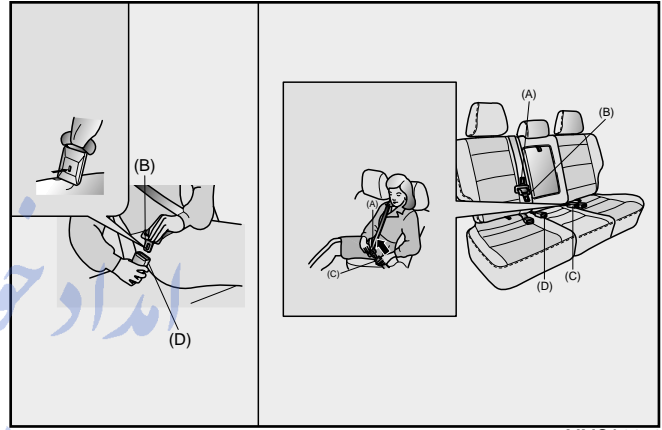

MMSA3073

1. Press the release button on the buckle (D) and remove the tongue plate (B) from the buckle (D).
2. Press the release button on the buckle (C) and remove the tongue plate (A) from the buckle (C).

The belt webbing will retract automatically.

# Knowing Your Vehicle

---

## ***Proper Use and Care of the Safety Belt System***

To ensure that the safety belts provide the maximum protection, please follow these instructions:

- Use the belts at all times - even on short trips.
- If the safety belt is twisted, straighten it prior to use.
- Keep sharp edges and damaging objects away from the belt.
- Periodically inspect belt webbing, anchors, buckles, and all other parts for signs of wear, and damage. Replace damaged, excessively worn or questionable parts immediately.
- To clean the belt webbing, use a mild soap solution recommended for cleaning upholstery or carpets. Follow the instructions provided with the soap. Do not bleach or dye the webbing because this may weaken the webbing fibers and allow them to fail when loaded in a collision.
- Do not make modifications or additions to the safety belt.
- After wearing a safety belt, make sure it fully retracts to the stowed position. Do not allow the belt to get caught in the door when you close it.

FarmaSOS.com

---

### ***Restraint of Pregnant Women***

Pregnant women should wear lap/shoulder belt assemblies whenever possible according to specific recommendations by their doctors. The lap portion of the belt should be worn AS SNUGLY AND AS LOW AS POSSIBLE.

#### **⚠ WARNING - Pregnant Women**

**Pregnant women must never place the lap portion of the safety belt over the area of the abdomen where the fetus is located or above the abdomen.**

### ***Restraint of Infants and Small Children***

To increase their safety, infants and young children should always be restrained by a restraint system approved for their age and size. for this reason, all states of The United States have laws governing the restraint of children.

#### **⚠ WARNING - Children on Lap**

**Never hold a child on your lap or in your arms in a moving vehicle. Even a very strong person cannot hold onto a child in the event of even a minor collision.**

Many companies manufacture child-restraint systems (often called child seats) for infants and small children. An acceptable child-restraint system must always satisfy U.S. Federal Motor Vehicle Safety Standards. Make sure that any child-restraint system you use in your vehicle is labeled as complying with those safety standards. The child restraint system should be chosen to fit both the size of the child and the size of the vehicle seat. Be sure to follow any instructions provided by the child restraint system manufacturer when installing the child-restraint system.

## **⚠️ WARNING - Infants and Young Children**

- Infants and young children are at much greater risk of serious injury or death in an accident or sudden stop if they are unrestrained or restrained improperly. follow all instructions in this section of your Kia manual and the instructions that came on and with an improved child safety restraint system. The child restraint must be correctly installed in the vehicle, and the child must be correctly installed in the child restraint.
- All children under 12 are safest in the back seat. The center rear position is best.
- Never install a rear-facing infant seat in the front passenger position. The baby will be injured or killed by the airbag if it deploys in an accident.

*(Continued)*

*(Continued)*

- Never allow a child to stand or kneel on the seat of a moving vehicle. Insist the child sit down in an approved restraint system.
- Never allow a safety belt to be placed around both a child and an adult or around two children. In an accident they will not be properly restrained and may receive worse injuries from being thrown forward or crushed against one another.
- Never allow a child to be held on a lap or in anyone's arms while the vehicle is moving. Even a very strong person cannot hold onto a child in even a minor collision.
- A child too large for a child restraint but too small for the vehicle safety belts should use an approved belt-positioning booster seat. this is safer than allowing a child to ride with a shoulder belt that touches their face or neck.

---

**⚠ WARNING - Hot Metal Parts**

**Since a safety belt or child restraint system can become very hot in a closed vehicle during warm sunny weather, be sure to check the seat cover and buckles before placing a child anywhere near them.**

***Restraint of Large Children***

As children grow, they may need to use new child restraints, including larger child seats or booster seats, which are appropriate for their increased size.

A child who has outgrown available child restraint systems should use the belts provided in the vehicle. When seated, the child should be restrained by the lap/shoulder belt.

If the shoulder belt slightly touches the child's neck or face, try placing the child closer to the center of the vehicle. If the shoulder belt still touches their face or neck, they may need to be returned to a child restraint system. In addition, after-market devices are available from independent manufacturers which help pull the shoulder belt lower and away from the child's face or neck.

امداد خود روفارما  
تلفن شبانه روزی: ۰۸۵ ۲۱ ۸۱۶۲  
FarmaSOS.com

# Knowing Your Vehicle

---

## ***Placement of a Child Restraint System***

We recommend that, whenever possible, you put the child restraint in the center position of the rear seat and secure it to the vehicle with the lap belt. If the center rear seat is not available, or you are using more than one child restraint system in the vehicle at the same time.

The rear outboard safety belts have been designed to allow a child restraint to be used in these positions. Since those safety belts normally lock only under extreme or emergency conditions (emergency lock mode) you must manually adjust those belts to the auto lock mode.

### **WARNING**

**When a child restraint is not in use, make sure that it is secured by a safety belt. In a sudden stop or accident, a loose child restraint could be thrown forward and injure someone.**

## **Installing a Child Restraint System in the Front Passenger Seat and Rear Outboard Seats**

For safety reasons, we recommend that the child restraint system be used in the center rear seat. If the center rear seat is unavailable, a rear-facing child restraint may be installed in the rear outboard seats. **Never place a rear-facing child restraint in the front passenger seat, because of the danger that an inflating passenger side air bag could impact the rear-facing child restraint and kill the child.**

Since all three of these safety belts move freely under normal conditions and only lock under extreme or emergency conditions (emergency lock mode), you must manually change these safety belts to the auto lock mode to secure a child restraint.

### **\* NOTICE**

The driver's safety belt incorporates the emergency lock mode only.

**⚠ WARNING - Restraint Instructions**

Failure to observe this manual's instructions regarding child restraint systems and the instructions provided with the child restraint system could increase the chance and/or severity of injury in an accident.

**⚠ WARNING - Child Restraint Placement**

Never use a rear-facing child restraint in the front passenger seat. In a collision the air bag inflates with great force. A child in a rear-facing restraint in the front passenger seat can be severely or fatally injured by the power of the air bag.

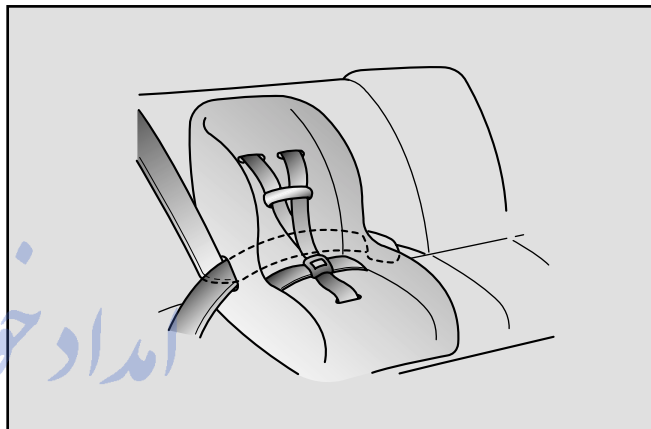

MMSA3027

***Placing a Passenger Safety Belt Into The Auto Lock Mode***

The use of the auto lock mode will ensure that the normal movement of the child in the vehicle does not cause the safety belt to be pulled out and loosen the firmness of its hold on the child restraint system. To secure a child restraint system in the front passenger seat or rear outboard seats, use the following procedure.

# Knowing Your Vehicle

## Installing a Child Restraint System in the Front Seat and Rear Outboard Seats

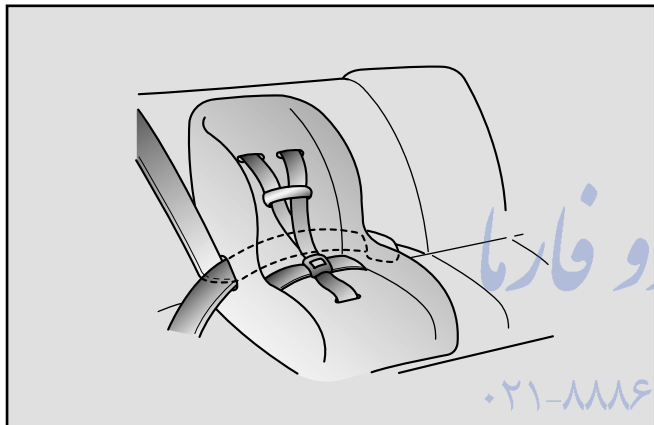

MMSA3027

1. Place the child restraint system in the seat and route the lap/shoulder belt around or through the restraint, following the restraint manufacturer's instructions. Be sure the safety belt webbing is not twisted.
2. Fasten the lap/shoulder belt latch into the buckle. Listen for the distinct "click" sound.

*Position the release button so that it is easy to access in case of an emergency.*

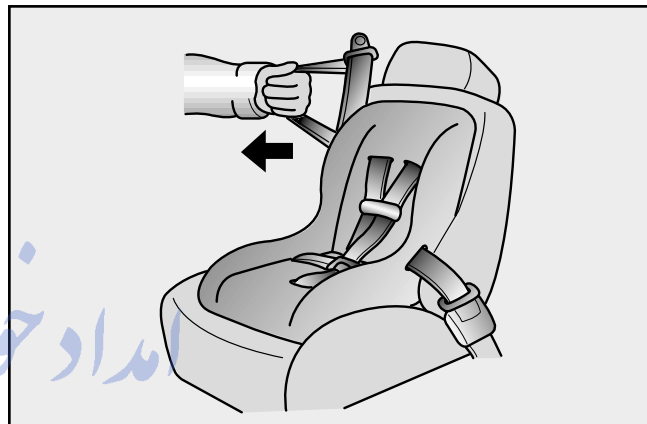

MMSA3028

3. Pull the shoulder portion of the safety belt all the way out. When the shoulder portion of the safety belt is fully extended, it will shift the retractor to the "Auto Lock" (child restraint) mode.

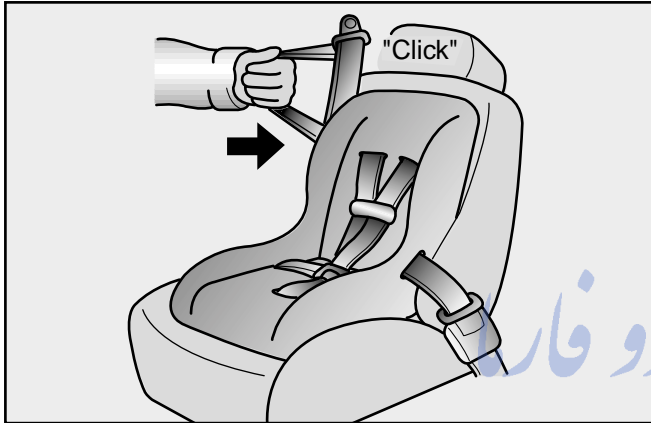

MMSA3029

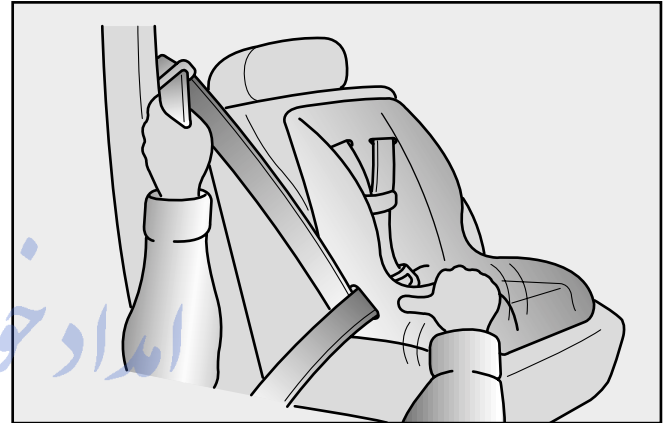

MMSA3030

4. Slowly allow the shoulder portion of the safety belt to retract and listen for an audible “clicking” or “ratcheting” sound. This indicates that the retractor is in the “Auto Lock” mode. If no distinct sound is heard, repeat steps 3 and 4.
5. Remove as much slack from the belt as possible by pushing down on the child restraint system while feeding the shoulder belt back into the retractor.
6. Push and pull on the child restraint system to confirm that the safety belt is holding it firmly in place. If it is not, release the safety belt and repeat steps 2 through 6.

# Knowing Your Vehicle

7. Double check that the retractor is in the “Auto Lock” mode by attempting to pull more of the safety belt out of the retractor. If you cannot, the retractor is in the “Auto Lock” mode.

To remove the child restraint, press the release button on the buckle and then pull the lap/shoulder belt out of the restraint and allow the safety belt to retract fully.

## **WARNING - Auto Lock Mode**

The lap/shoulder belt automatically returns to the “emergency lock mode” whenever the belt is allowed to retract fully. Therefore, the preceding seven steps must be followed each time a child restraint is installed.

If the safety belt is not placed in the “auto lock” mode, severe injury or death could occur to the child and/or other occupants in the vehicle in a collision, since the child restraint will not be effectively held in place.

## **\* NOTICE**

When the safety belt is allowed to retract to its fully stowed position, the retractor will automatically switch from the “Auto Lock” mode to the emergency lock mode for normal adult usage.

## ***Installing a Child Restraint System in the Rear Center Seat***



MMSA3031

To install a child restraint in the rear center seat, do the following:

1. Place the child-restraint in the desired position. Route the lap/ shoulder belt through the restraint according to the seat manufacturer's instructions.
2. Insert the tongue plate into the buckle.
3. Adjust the lap/ shoulder safety belt for a snug hold on the child restraint by pulling on the loose end of the belt.

## **Child seat anchorage position**

For small children and babies, the use of a child seat or infant seat is strongly recommended. This child seat or infant seat should be of appropriate size for the child and should be installed in accordance with the manufacturer's instructions. It is further recommended that the seat be placed in the vehicle's rear seat since this can make an important contribution to safety. Your vehicle is provided with three child restraint hook holders on the package tray behind the rear seat for installing the child seat or infant seat.

### **⚠ WARNING - Child Restraint Placement**

**Never use a child restraint in the front passenger seat. A child in a child restraint installed in the front passenger seat can be severely or fatally injured by an air bag which could impact the child restraint with great force when the air bag inflates.**

# Knowing Your Vehicle

## Child restraint anchorage position

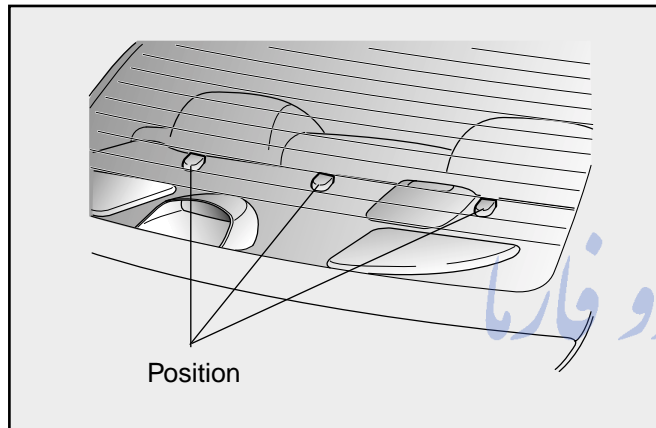

Your vehicle is equipped with an anchor for securing the tether strap of a child restraint system (child seat).

The child restraint anchor fittings are installed on the shelf behind the rear seat.

### **⚠ WARNING**

**If the tether strap is clipped incorrectly, the child restraint seat may not be restrained properly in the event of a collision.**

Installing a child restraint seat ;

1. Position the child restraint seat on the rear passenger seat cushion.
2. Route the child restraint seat tether strap over the back of the seat.

For vehicles with adjustable head restraints, route the tether strap under the head restraint and between the head restraint posts, otherwise route the tether strap over the top of the seatback.

3. Locate the correct anchor on the package tray behind the rear seat for the selected seating position.
4. Open the tether anchor cover.
5. Clip the tether strap hook to the tether strap hook holder.
6. Tighten the tether strap to secure the seat.

### **⚠ WARNING - Child Restraint**

Check that the child restraint system is secure by pushing and pulling it in different directions. Incorrectly fitted child restraints may swing, twist, tip or come away causing death or injury.

### **⚠ WARNING - Child Restraint Anchorage**

- Child restraint anchorages are designed to withstand only those loads imposed by correctly fitted child restraints. Under no circumstances are they to be used for adult seat belts or harnesses or for attaching other items or equipment to the vehicle.
- The tether strap may not work properly if attached somewhere other than the correct tether anchor.

### **Child seat lower anchors**

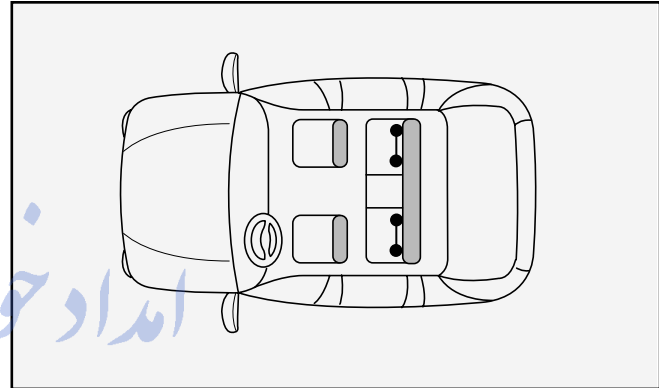

MMSA3082

Some child seat manufacturers make child restraint seats that are labeled as ISOFIX or ISOFIX-compatible child restraint seats. These seats include two rigid or webbing mounted attachments that connect to two ISOFIX anchors at specific seating positions in your vehicle. This type of child restraint seat eliminates the need to use seat belts to attach the child seat for forward-facing child restraint seats.

# Knowing Your Vehicle

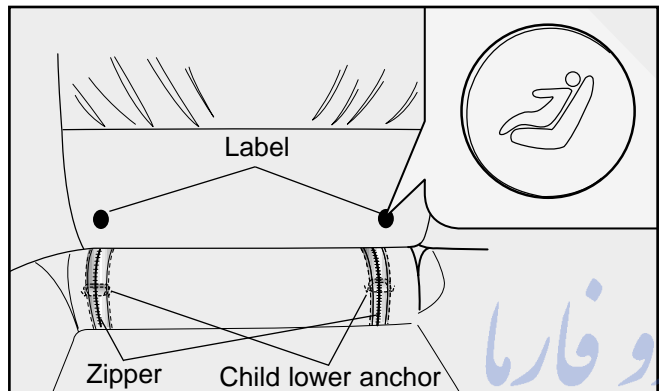

MMSB3035

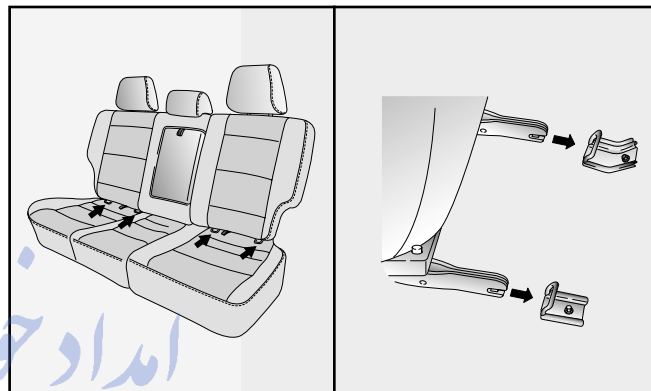

S2BLC354/MMSA3036

There is a symbol located on the lower portion of each side of the rear seatbacks. These symbols indicate the position of the lower anchors for child restraints so equipped. A zipper is located directly beneath each indicator, which when opened will expose the metal anchor.

ISOFIX anchors have been provided in your vehicle. The ISOFIX anchors are located in the left and right outboard rear seating positions. Their locations are shown in the illustration. There is no ISOFIX anchor provided for the center rear seating position.

The ISOFIX anchors are located between the seatback and the seat cushion of the rear seat left and right outboard seating positions.

Follow the child seat manufacturer's instructions to properly install child restraint seats with ISOFIX or ISOFIX-compatible attachments.

Once you have installed the ISOFIX child restraint, assure that the seat is properly attached to the ISOFIX and tether anchors. Also, test the child restraint seat before you place the child in it. Tilt the seat from side to side. Also try to tug the seat forward. Check to see if the anchors hold the seat in place.

**⚠ WARNING**

- If the child restraint is not anchored properly, the risk of a child being seriously injured or killed in a collision greatly increases.
- Do not mount more than one child restraint to a single tether or to a child restraint lower anchorage point. The improper increased load may cause the anchorage points or tether anchor to break, causing serious injury or death.

- Do not install a child restraint seat at the rear center seating position using the vehicle's ISOFIX anchors. The ISOFIX anchors are only provided for the left and right outboard rear seating positions. Do not misuse the ISOFIX anchors by attempting to attach a child restraint seat in the middle rear seating position to the ISOFIX anchors. In a crash, the child restraint seat ISOFIX attachments may not be strong enough to secure the child restraint seat improperly in the rear center seating position and may break, causing serious injury or death.
- Attach the ISOFIX or ISOFIX-compatible child restraint seat only to the appropriate locations shown in the illustration.
- Always follow the installation and use instructions provided by the manufacturer of the child restraint.

# Knowing Your Vehicle

---

## **AIR BAG - SUPPLEMENTAL RESTRAINT SYSTEM**

### **What Your Air Bag System Does**

Your vehicle is equipped with a dual Supplemental Restraint System (SRS), which includes an airbag for the driver and another airbag for the front seat passenger. The airbag for the driver is in the steering wheel and is designed to help restrain the forward movement of the driver's head and chest in certain frontal collisions. The passenger airbag is designed to help restrain the forward movement of the passenger's head and chest in certain frontal collisions.

### **What Your Air Bag System Does Not Do**

The air bag system is designed to supplement or add to the protection offered by the safety belt system. IT IS NOT A SUBSTITUTE FOR THE SAFETY BELT.

### **Why Didn't My Air Bag Go Off in a Collision?**

There are many types of accidents in which the air bag would not be expected to provide additional protection. These include side or rear impacts, rollovers, and second or third collisions in multiple-impact accidents, as well as low speed impacts.

Remember, air bags are only designed to inflate when the impact would throw the occupant into the air bags – generally from an area a little to the left to a little to the right of straight ahead.

In other words, just because your vehicle is damaged and even if it is totally unusable, don't be surprised that the air bags did not inflate.

## ***The Importance of Using Safety Belts***

There are four very important reasons to use safety belts even with an air bag supplemental restraint system. They:

- help keep you in the proper position (away from the air bag) when it inflates.
- reduce the risk of harm in rollover, side or rear impact collisions, because an air bag is not designed to inflate in such situations.
- reduce the risk of harm in frontal collisions which are not severe enough to actuate the air bag supplemental restraint system.
- reduce the risk of being thrown from your vehicle.

### **\* NOTICE**

Your vehicle's Supplemental Restraint System Control Module is equipped with a recording device that may record the use or status of the seat belt restraint system by the driver and front passenger in certain collisions.

## **⚠ WARNING - Air Bags & Safety Belts**

- **Even in vehicles with air bags, you and your passengers must always wear the safety belts provided in order to minimize the risk and severity of injury in the event of a collision or rollover.**
- **Always wear your safety belt. It can help keep you away from the air bags during heavy braking just before a collision.**
- **Air bags are designed to inflate only in certain frontal collisions and will generally not provide protection in side or rear impacts, rollovers or less severe frontal collisions. They will not provide protection from later impacts in a multi-impact collision.**
- **If your vehicle has been subjected to flood conditions (e.g. soaked carpeting/standing water on the floor of the vehicle, etc.) or if your vehicle has become flood damaged in any way, do not**

***(Continued)***

# Knowing Your Vehicle

**(Continued)**

**attempt to start the vehicle or put the key in the ignition before disconnecting the battery. This may cause air bag deployment, which could result in serious personal injury or death. Have the vehicle towed to an authorized Kia dealer for inspection and necessary repairs.**

## ***Air Bag System Components***

The main components of your SRS are:

- An air bag in the steering wheel.
- A second air bag in the passenger's side dashboard.
- A diagnostic system that continually monitors system operation.
- An indicator light to warn you of a possible problem with the system.
- Emergency power backup in case the electrical system in your car is disconnected in a crash.

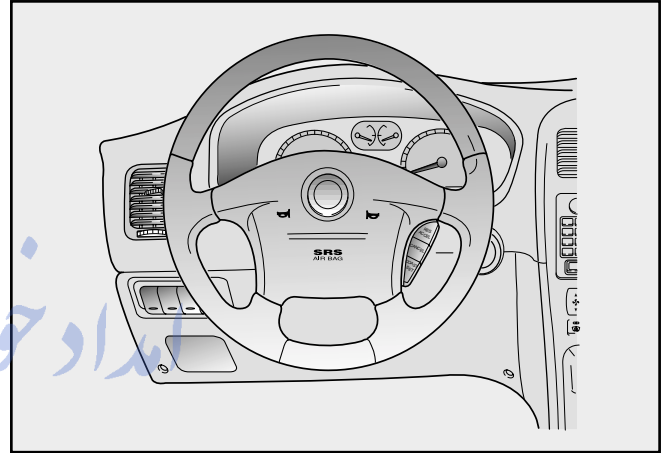

MMSA3037A

To indicate that your vehicle is equipped with driver's and passenger's side air bags, the air bag covers on the steering wheel and on the dashboard are marked "SRS AIR BAG."

Passenger's side air bag

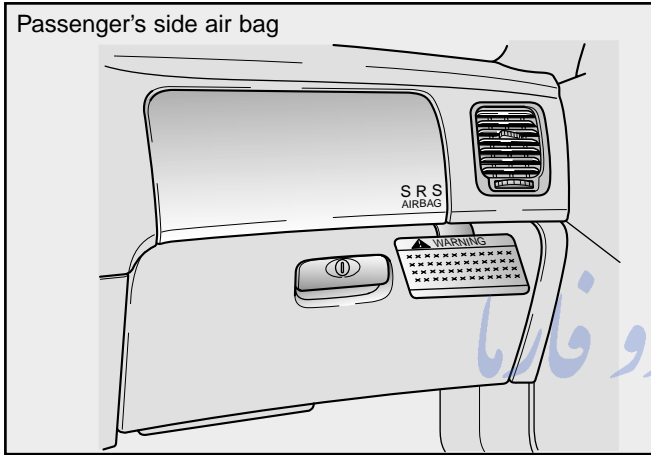

MMSA3038

### ***How the Driver's Air Bags (SRS) Work***

The driver's air bags are stored in the steering wheel hub. The passenger's air bag is stored in the dashboard above the glove box.

In certain frontal collisions, your air bags will instantly inflate to help protect you from serious physical injury or death.

There is no single vehicle speed at which the air bags will inflate. Generally, air bags are designed to inflate in certain frontal collisions. The air bag Supplemental Restraint System (SRS) reacts to the severity of a collision and its direction. These two factors determine whether the sensors send out an electronic deployment/inflation signal. Whether the air bags will inflate depends on a number of factors including vehicle speeds, angles of impact and the density and stiffness of the vehicles or objects which your vehicle hits in the collision.

The air bags are designed to inflate instantly in the event of a certain frontal collisions in order to help protect the driver and passenger from serious physical injury.

# Knowing Your Vehicle

The air bags will completely inflate and deflate in less than 1/10 of a second. The speed of inflation and deflation protects the driver's ability to operate the vehicle. This is important in crashes where a vehicle continues to move after an impact and the driver still has some control of the vehicle's steering, braking, throttle and/or transaxle systems.

It is virtually impossible for you to see the air bags inflate during an accident. It is much more likely that you will simply see the deflated air bags hanging out of their storage compartments after the collision.

In order to help provide protection in a severe collision, the air bags must inflate rapidly. However, that speed also causes the air bags to expand with a great deal of force. The speed of air bag inflation is a consequence of the extremely short time in which a collision occurs and the need to get the air bag between the occupant and the vehicle structures before the occupant impacts those structures. This speed of inflation reduces the risk of serious or life-threatening injuries in a severe collision and is thus a necessary part of air bag design.

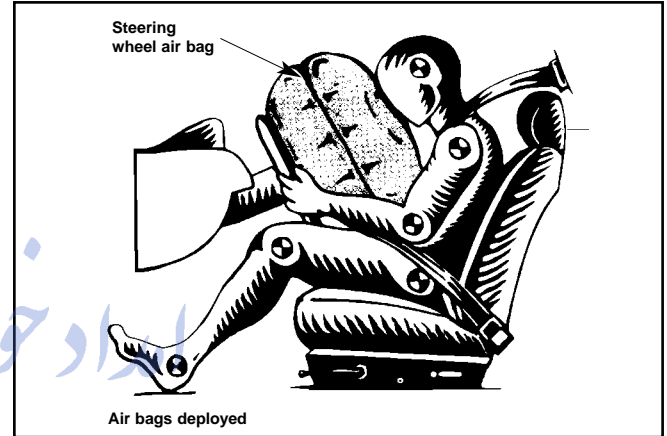

AS2B03033  
However, air bag inflation can also cause injuries which normally can include facial abrasions, bruises and broken bones.

**There are even circumstances under which contact with the steering wheel air bag can cause fatal injuries, especially if the occupant is positioned excessively close to the steering wheel.**

### **⚠ WARNING - Air Bag Injuries**

- You must always sit as far back from the steering wheel air bag as possible, while still maintaining a comfortable seating position for good vehicle control, in order to reduce the risk of injury or death in a collision.
- Never place objects over the air bag storage compartments or between the air bags and yourself. Due to the speed and force of the air bag inflation, such objects could hit your body at high speed and cause severe bodily injury and even death.
- Do not put stickers or ornaments or the steering wheel cover. These may interfere with the deployment of the air bag.

### **Noise and Smoke**

When the air bags inflate, they make a loud noise and they leave smoke and powder in the air inside of the vehicle. This is normal and is a result of the ignition of the air bag inflator.

After the air bags inflate, you may feel substantial discomfort in breathing due to the contact of your chest to both the safety belt and the air bag, as well as from breathing the smoke and powder.

**We strongly urge you to open your doors and/or windows as promptly as possible after impact in order to reduce discomfort and prevent prolonged exposure to the smoke and powder.** تلفن ۰۸۰۲۰۶۳۸۳

### **⚠ WARNING - Hot Metal Parts**

When the air bags deploy, the air bag inflators in the steering wheel and/or below the dashboard are very hot. To prevent injury, do not touch the air bag storage areas internal components immediately after an air bag has inflated.

# Knowing Your Vehicle

## *The Importance of the Passenger Being Properly Seated*

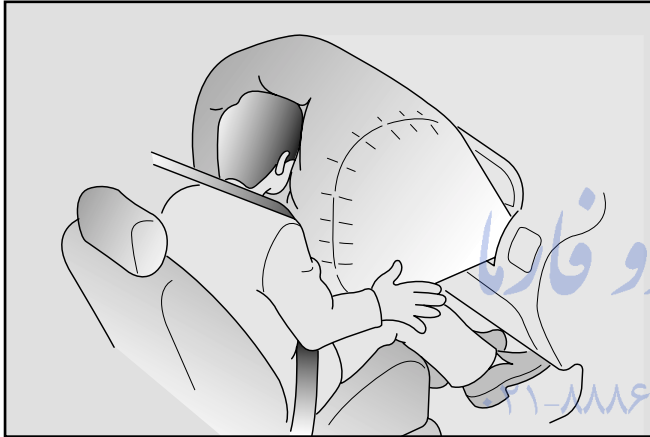

The front seat passenger's air bag is much larger than the steering wheel air bag and inflates with considerably more force. It can seriously hurt or kill a passenger who is not in the proper position and wearing the safety belt properly. The front passenger should always move their seat as far back as practical and sit back in their seat.

It is essential that the front passenger always wear their safety belt, even when the vehicle is moving in a parking lot or up a driveway into a garage. The reason for this is that in most frontal impacts, the occupants are thrown forward. If the right front passenger is not wearing their safety belt, they will be directly in front of the storage compartment when inflation occurs. In that situation, serious injury or death is possible.

**⚠ WARNING - Right Front Seat**  
Pre-impact braking could throw an unbelted passenger toward or onto the air bag storage compartment. In the collision, the air bag would rapidly inflate and could severely injure or kill the unbelted occupant.

## **⚠ WARNING - Front Passengers**

- **Never place a rear-facing child restraint in the front seat. A rear-facing child restraint would be positioned too close to the air bag. If the air bag deploys, it would impact the rear-facing child restraint, causing serious or fatal injury.**
- **Failure to observe the instructions provided with the child restraint system could increase the risk and/or severity of injury in an accident.**

## ***Air Bag Warning Light***

The purpose of the air bag warning light in your instrument panel is to alert you of a potential problem with your Air Bag - Supplemental Restraint System (SRS).

Have the system checked if:

- The light does not illuminate briefly when you turn the ignition ON.
- The light stays on after the engine starts.
- The light comes on or flashes while you are driving.

Air Bag Warning Light

**AIR  
BAG**

تلفن شبانه روزی: ۰۲۱-۸۸۸۶۲۰۸۵

FarmaSOS.com

# Knowing Your Vehicle

## ***Supplemental Restraint System Service***

Your Supplemental Restraint System is virtually maintenance-free. There are no parts which you can service.

You must have the system serviced under the following circumstances:

- If an air bag ever inflates, the air bag must be replaced. Do not try to remove or discard the air bag by yourself. This must be done by an authorized Kia dealer or service representative.
- If the air bag warning indicator light alerts you to a problem, have the air bag system checked as soon as possible. Otherwise, your air bag may not perform properly.

The entire SRS system must be inspected by an authorized Kia dealer 10 years after the vehicle manufacture date.

### **⚠ WARNING - No modifications**

- Do not modify any part of the airbag system. Modification could make the airbag system ineffective.

*(Continued)*

*(Continued)*

- Manufacturers are required by government regulations to provide a contact point concerning modifications to the vehicle for persons with disabilities, which modifications may affect the vehicle's air bag system. That contact is Kia's toll-free Customer Assistance hotline at 1-800-333-4KIA.

### **⚠ WARNING - No maintenance or repair**

- Do not work on the airbag system's components or wiring. This could cause the airbags to inflate inadvertently, possibly seriously injuring someone. Working on the system could also disable the system so that the airbags would not deploy in a collision.
- Any work on the airbag system, such as removing, installing, or repairing the steering wheel must be performed by a qualified Kia technician. Improper handling of the airbag system including the steering wheel may result in serious personal injury or death.

---

### ***Passenger Presence Detection***

The passenger presence detection system detects the presence of a passenger in the front seat. If no passenger is recognized on the front passenger seat, the deployment of the front passenger and/or side airbag will be prevented. This system is designed to prevent the replacement of airbag components that deploy needlessly in an accident.

### **⚠ WARNING**

**The Passenger Presence Detection system is not intended to prevent airbag deployment while a child is in the front passenger's seat. It is intended only as a means to reduce unnecessary collision damage repair expense by preventing airbag and seat belt pretensioner deployment when the right front passenger seat is unoccupied. Deployment is still possible if only a few pounds are placed upon the seat. Therefore, children must not be seated in the front seat. All children must be seated in the rear seat and properly restrained with the vehicle's restraint system or a child restraint system appropriate for the child's size and weight.**

# Knowing Your Vehicle

## Side Airbag (if equipped)

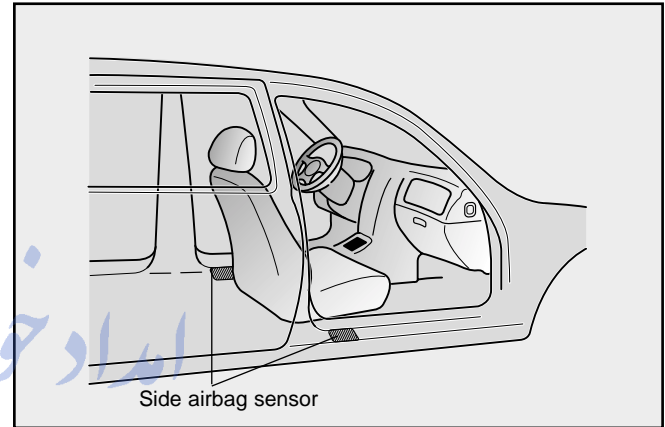
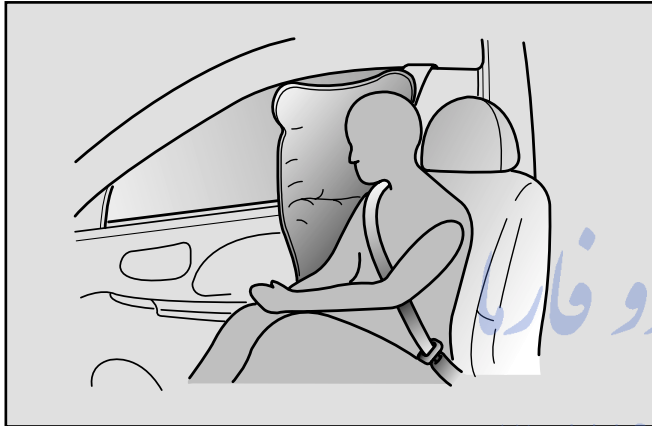

Your vehicle is equipped with a side airbag in each front seat. The purpose of the airbag is to provide the vehicle's driver and/or the front passenger with additional protection other than that offered by the seatbelt alone. The side impact airbags are designed to deploy only during certain side-impact collisions, depending on the crash severity, angle, speed and point of impact. The air bags are not designed to deploy in all side impact situations.

### **⚠ WARNING**

- For best protection from the side airbag system and to avoid being injured by the deploying side airbag, both front seat occupants should sit in an upright position with the seat belt properly fastened.

(Continued)

(Continued)

Side airbags are relatively new to vehicle design and the National Highway Traffic Safety Administration is still collecting data on their effectiveness. However, they can provide the most protection - and you can reduce your risk of airbag caused injuries - if you maintain a proper seating position.

- Do not use any accessory seat covers. Use of seat covers could reduce the effectiveness of the system.
- Do not install any accessories on the side or near the side airbag.
- Do not place any objects (umbrella, bag, etc.) between the front door and the front seat. Such objects may either interfere with the side airbag deployment or could become potentially dangerous projectiles.

### **Airbag Warning Label (sunvisor)**



MMSA3042

To remind you of the dangers of the airbag, airbag warning labels which are now required by the U.S. National Highway Traffic Safety Administration (NHTSA) are adhered to the driver's and passenger's sunvisors and attached to the glove box.

Note that these government warnings focus on the risk to children, Kia also wants you to be aware of the risks which adults are exposed to. Those have been described in previous pages.

# Knowing Your Vehicle

## TRUNK LID

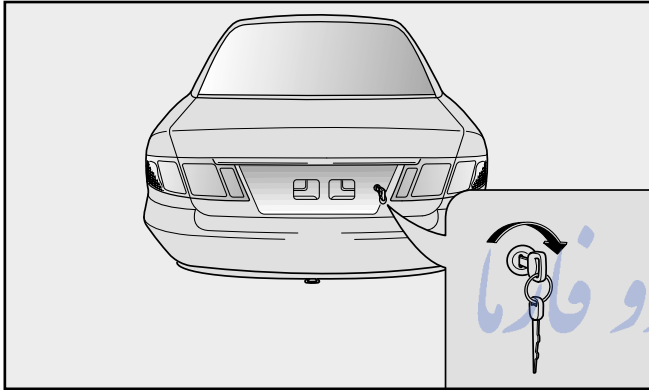

MMSA3043

- To open the trunk, insert the key into the lock and turn it clockwise until an audible “click” is heard.
- To close the trunk, use both hands to push the trunk lid down until the lock “snaps” shut.
- Do not slam the trunk lid.
- Pull up on the trunk lid to make sure it is securely latched.

To prevent premature wear or damage to the trunk lid lift cylinders and attaching hardware, the trunk lid must be fully closed before you drive your vehicle.

### **⚠ WARNING - Exhaust Fumes**

If you drive with the trunk lid open, you will draw dangerous exhaust fumes into your vehicle.

If you must drive with the trunk lid open, keep the air vents open so that additional outside air comes into the vehicle.

### **⚠ PROPOSITION 65 WARNING**

Engine exhaust and a wide variety of automobile components and parts, including components found in the interior furnishings in a vehicle, contain or emit chemicals known to the State of California to cause cancer and birth defects and reproductive harm. In addition, certain fluids contained in vehicles and certain products of component wear contain or emit chemicals known to the State of California to cause cancer and birth defects or other reproductive harm.

## Emergency Trunk Safety Release (If Equipped)

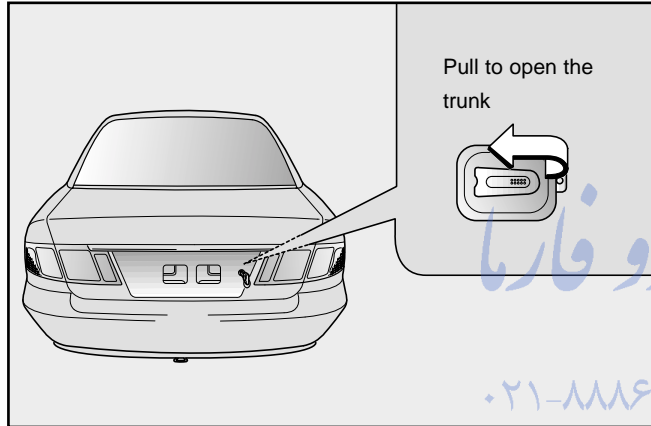

MMSA3044A

Your vehicle is equipped with an emergency trunk release cable located inside the trunk inside of the right tail light. If someone is inadvertently locked in the trunk, when pulled, this cable will release the trunk latch mechanism and open the trunk.

## **⚠ WARNING**

No one should be allowed to occupy the trunk of the vehicle at any time. If the trunk is partially or totally latched and the person is unable to get out, severe injury or death could occur due to lack of ventilation, exhaust fumes and rapid heat build-up, or because of exposure to cold weather conditions. The trunk is also a highly dangerous location in the event of a crash because it is not a protected occupant space but merely a part of the vehicle's crush zone.

# Knowing Your Vehicle

## \* NOTICE

- If a person is locked in the trunk, they can pull the emergency release to open the trunk lid.
- We recommend that cars be kept locked and keys be kept out of the reach of children, and that parents teach their children about the dangers of playing in trunks.

## Remote Trunk Lid Release

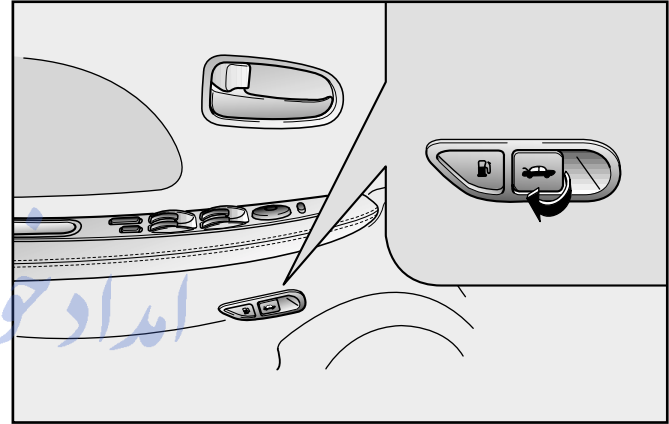

MMSA3045

To open the trunk, pull the release switch toward you.

FarmaSOS.com

## Trunk Lid Knob Lock

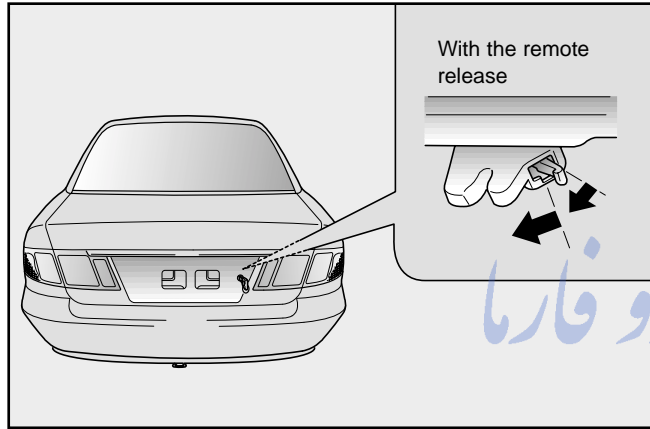

MMSA3046A

If the trunk lid lock knob (located near the latch) is in the “LOCK” position when the trunk lid is closed, it will not be possible to open the trunk lid by using the remote release. In this instance, use the master key to unlock and open the trunk lid. To allow the trunk lid to be opened with the remote release, push the trunk lid lock knob down, then to the opposite direction of the “LOCK” position.

## HOOD

### Opening the Hood:

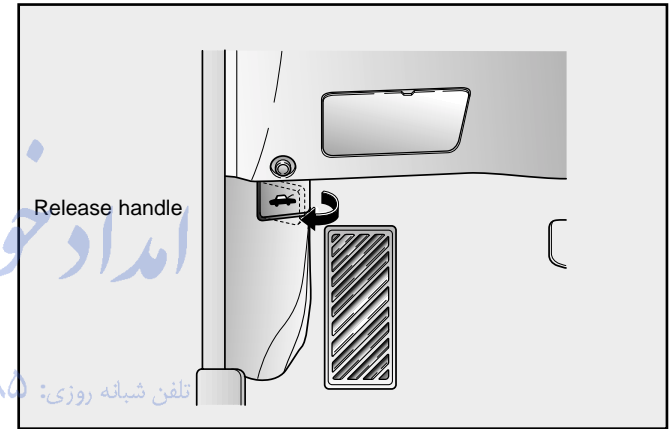

MMSA3047

1. Pull the release lever on the lower left side of the instrument panel to unlatch the hood.

# Knowing Your Vehicle

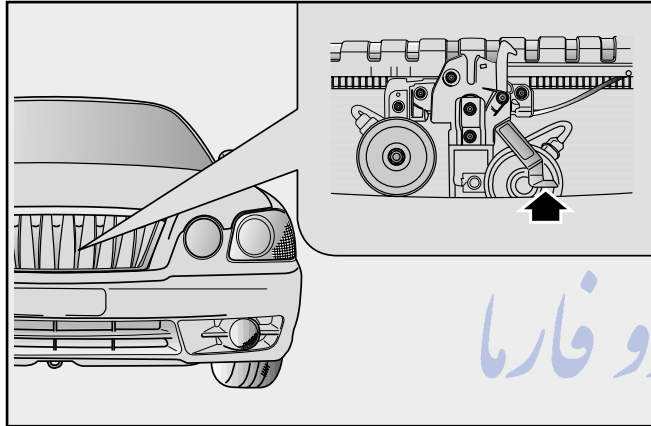

MMSA3074

2. Go to the front of the vehicle, slightly raise the hood, pull up on the secondary latch and lift the hood.
3. Raise the hood. It will raise completely by itself after it has been raised halfway.

## ***Closing the Hood:***

- Check the area under the hood to make certain all filler caps are in place and that all loose items have been removed.
- Lower the hood then push down to properly lock in place.
- Check to make sure the hood is closed.

### **⚠ WARNING**

- Before closing the hood, make sure that all engine parts and tools have been removed from the engine area and that no one's hands are near the hood opening.
- Do not leave gloves, rags or any other combustible material in the engine compartment. Doing so may cause a heat-induced fire.

## FUEL FILLER LID

### Remote Fuel Filler Lid Release (If equipped)

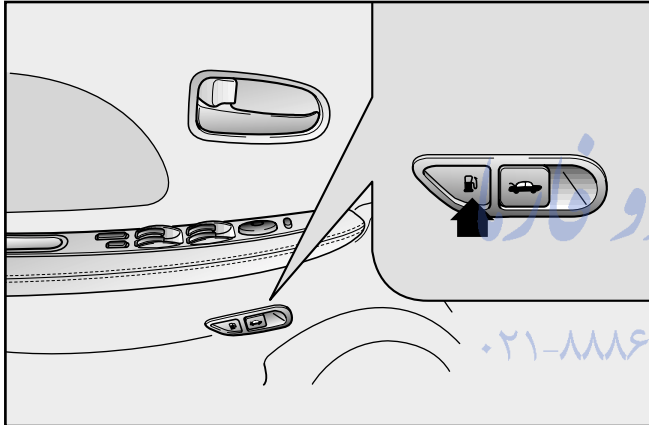

MMSA3048

Depress on the release button located on the driver's door to open the fuel filler lid.

### **⚠ WARNING**

To avoid injury from sharp objects, it is recommended that protective gloves be worn when opening the fuel filler door manually.

### **⚠ WARNING - Refueling**

If pressurized fuel sprays out, it can cause serious injuries. Always remove the fuel cap carefully and slowly. If the cap is venting fuel or if you hear a hissing sound, wait until the condition stops before completely removing the cap.

### **⚠ WARNING**

Automotive fuels are flammable/explosive materials. When refueling, please note the following guidelines carefully. Failure to follow these guidelines may result in severe personal injury, severe burns or death by fire or explosion.

- Before refueling always note the location of the Emergency Gasoline Shut-Off, if available, at the gas station facility.

(Continued)

# Knowing Your Vehicle

---

**(Continued)**

- Before touching the fuel nozzle or fuel filler cap, you should eliminate potentially dangerous static electricity discharge by touching another metal part of the front of the vehicle, a safe distance away from the fuel filler neck, nozzle, or other gas source.
- Do not get back into a vehicle once you have begun refueling. Do not touch, rub or slide against any item or fabric (polyester, satin, nylon, etc.) capable of producing static electricity. Static electricity discharge can ignite fuel vapors resulting in explosion. If you must re-enter the vehicle, you should once again eliminate potentially dangerous static electricity discharge by touching a metal part of the vehicle, away from the fuel filler neck, nozzle or other gasoline source.

**(Continued)**

**(Continued)**

- When using a portable fuel container be sure to place the container on the ground prior to refueling. Static electricity discharge from the container can ignite fuel vapors causing a fire. Once refueling has begun, contact with the vehicle should be maintained until the filling is complete. Use only portable fuel containers designed to carry and store gasoline.
- Do not use cellular phones around a gas station or while refueling any vehicle. Electric current and/or electronic interference from cellular phones can potentially ignite fuel vapors causing a fire. If you must use your cellular phone, use it in a place away from the gas station.

**(Continued)**

**(Continued)**

- **When refueling always shut the engine off. Sparks produced by electrical components related to the engine can ignite fuel vapors causing a fire. Always insure that the engine is OFF before and during refueling. Once refueling is complete, check to make sure the fuel filler cap and door are securely closed, before starting the engine.**
- **Do not light any fire around a gas station. DO NOT use matches or a lighter and DO NOT SMOKE or leave a lit cigarette in your vehicle while at a gas station especially during refueling. Automotive fuel is highly flammable and can, when ignited, result in explosion by flames.**
- **If a fire breaks out during refueling, leave the vicinity of the vehicle, and immediately contact the manager of the gas station or contact the police and local fire department. Follow any safety instructions they provide.**

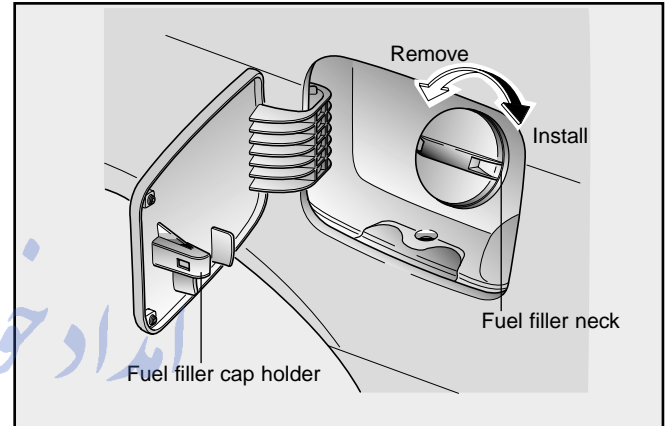

MMSA3049

- To remove the cap, turn it counter-clockwise.
- To install the cap, turn it clockwise until it “clicks.” This indicates that the cap is securely tightened.

# Knowing Your Vehicle

## \* NOTICE

- If the fuel filler cap requires replacement, use only a genuine Kia cap or the equivalent specified for your vehicle. An incorrect fuel filler cap can result in a serious malfunction of the fuel system or emission control system. Correct replacement caps are available at authorized Kia dealers.
- Do not spill fuel on the exterior surfaces of the vehicle. Any type of fuel spilled on painted surfaces may damage the paint.
- A loose fuel filler cap may cause the “Check Engine” (Malfunction Indicator) light in the instrument panel to illuminate unnecessarily.
- If the fuel filler lid will not open in cold weather because the area around it is frozen, push or lightly tap the lid.
- The fuel filler neck is designed to prevent filling the fuel tank with anything but unleaded fuel.

## STEERING WHEEL

### Horn

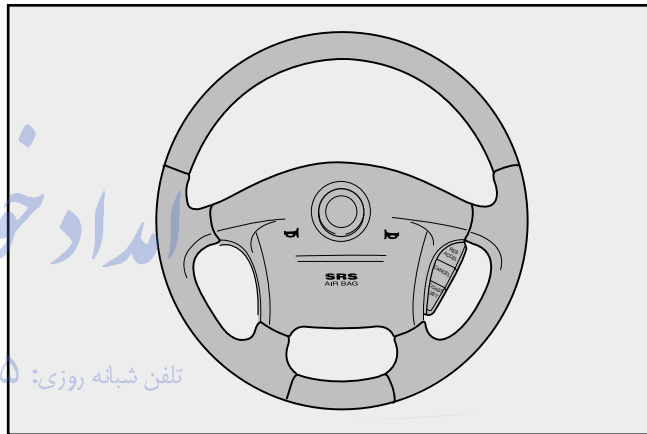

MMSA3050

To sound the horn, press the horn symbol on your steering wheel.

Check the horn regularly to be sure it operates properly.

## Tilt Steering (If equipped)

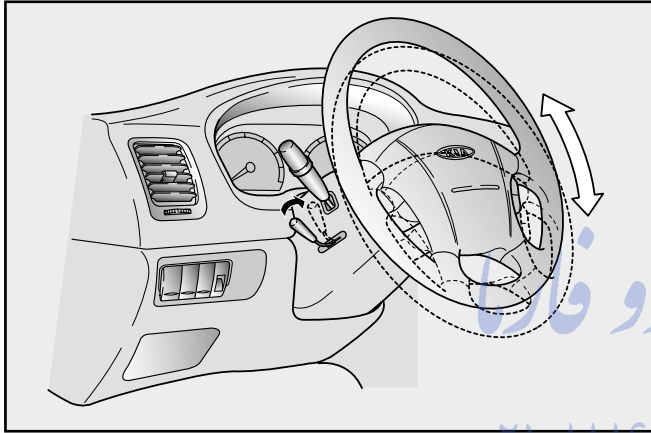

### **⚠ WARNING - Tilt Steering**

- Never adjust the position of the steering wheel while the vehicle is in motion, or you may lose control of the vehicle.
- After adjusting, push the steering wheel up and down to be certain it is locked in position.

To change the steering wheel angle, pull up on the lock release (located beneath the steering column), adjust the steering wheel to the desired angle, then release the lock-release to lock the steering wheel in place. The steering wheel should be positioned so that it feels comfortable to you when driving, while permitting you to see the instrument panel warning lights and gauges.

MMSA3051

تلفن شبانه روزی: ۰۸۵-۰۲۱۲۲۲۲۲۲۲

www.asos.com

# Knowing Your Vehicle

## Mirrors

### Outside Rearview Mirrors

Be sure to adjust mirror angles before driving.

#### **⚠ WARNING - Convex Mirror**

- The right outside rearview mirror is convex. Objects seen in the mirror are closer than they appear. When changing lanes, use your inside rearview mirror or direct observation to determine the actual distance of following vehicles.

#### **\* NOTICE**

Do not scrape ice off the mirror face; this may damage the surface of the glass. If ice should restrict movement of the mirror, do not force the mirror for adjustment. To remove ice, use a de-icer spray, or a sponge or soft cloth with very warm water.

### Outside Rearview Mirrors Electric Remote Control (If equipped)

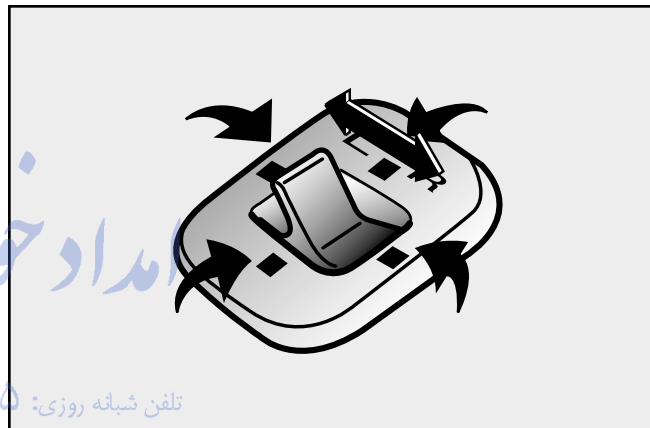

MMSA3052

The electric remote control mirror switch, located on the left side of the instrument panel on the drivers door, allows you to adjust the position of the left and right outside rearview mirrors. To adjust the position of either mirror, move the lever to R or L to select the right side mirror or the left side mirror, then press a mark (■) on the mirror adjustment control to position the selected mirror up, down, left or right.

## \* NOTICE

The mirrors stop moving when they reach the maximum adjusting angles, but the motor continues to operate while the switch is depressed. Do not depress the switch longer than necessary, the motor may be damaged.

## ***Outside Rearview Mirror Heater (If equipped)***

The outside door mirror heater is actuated in connection with the rear window defroster. To heat the outside door mirror glass, push the switch for the rear window defroster.

The outside door mirror glass will be heated for defrosting or defogging and will give you improved rear vision in inclement weather conditions. Push the switch again to turn the heater off. The outside door mirror heater automatically turns itself off after 15 minutes. (Refer to Defroster)

تلفن شبانه روزی: ۰۲۱-۸۸۸۶۲۰۸۵

FarmaSOS.com

# Knowing Your Vehicle

## Day/Night Rearview Mirror

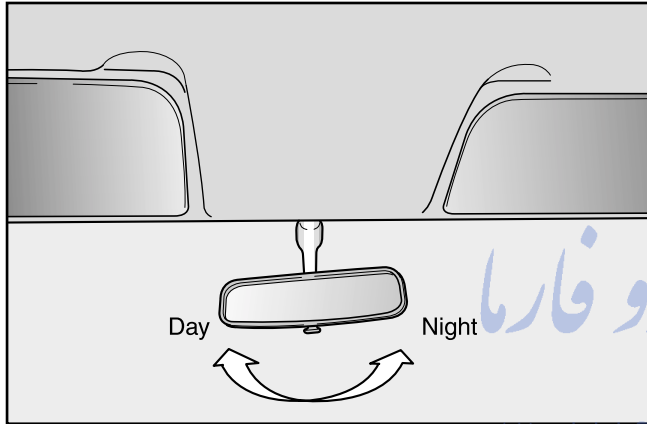

### **CAUTION**

*Do not place objects in the rear seat or cargo area which would interfere with your vision out the rear window.*

Adjust the rearview mirror to center on the view through the rear window. Make this adjustment before you start driving and while the day/night lever is in the day position.

Pull the day/night lever toward you to reduce glare from the headlights of vehicles behind you during night driving. Remember that you lose some rearview clarity in the night position.

## Electric type (if equipped)

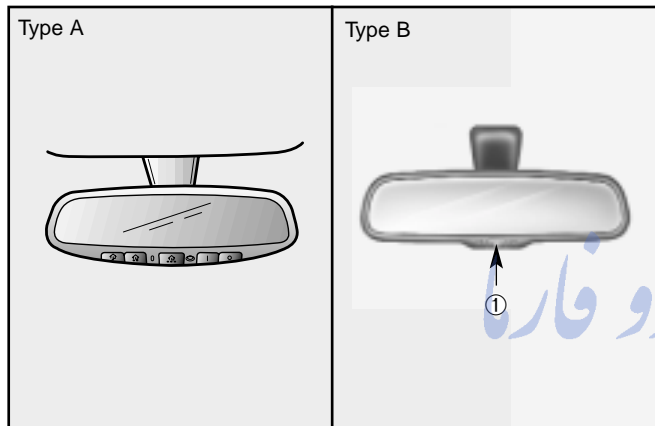

MMSA3075A/1KMA3084

The electric day/night rearview mirror automatically controls the glare from the headlights of the car behind you. Adjust the rearview mirror to the desired position.

### Type A

Press the “O” button to turn the automatic-dimming function off. The mirror indicator light will turn off.

Press the “I” button to turn the automatic-dimming function on, The mirror indicator light will illuminate.

### Type B

When the ignition switch is ON, the automatic-dimming function will turn on automatically.

Press the ON/OFF button (①) to turn the automatic- dimming function off. The mirror indicator light will turn off.

Press the ON/OFF button (①) once again to turn the automatic- dimming function on. The mirror indicator light will illuminate.

### **CAUTION**

*Do not place objects in the rear seat or cargo area which would interfere with your vision out the rear window.*

### **\* NOTICE**

When cleaning the mirror, use a paper towel or similar material dampened with glass cleaner. Do not spray glass cleaner directly on the mirror as that may cause the liquid cleaner to enter the mirror housing.

# Knowing Your Vehicle

## INTERIOR LIGHTS

### *Dome Light*

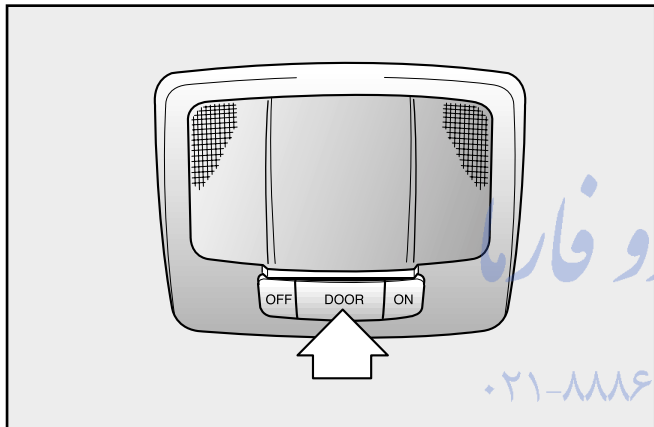

MMSA3054

The dome light switch, located in the light assembly, has three positions:

- OFF - The light stays off even when a door is open.
- DOOR - The light turns on or off when a door is opened or closed.
- ON - The light turns on and stays on even when the doors are all closed.

### *Map Light (sunroof)*

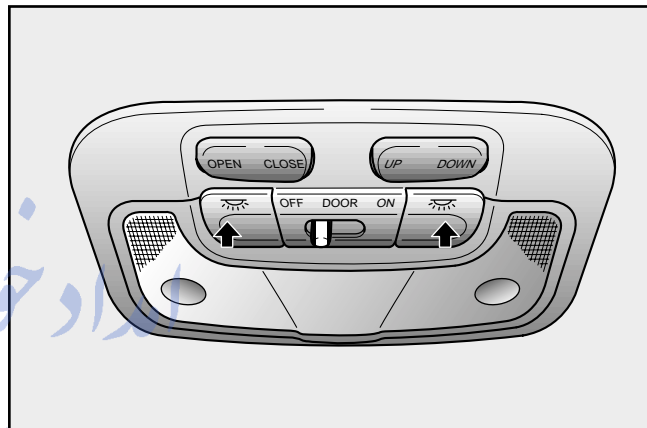

MMSA3055

This light switch has three positions:

- OFF - The light stays OFF even when a door is open.
- DOOR - The driver's side light turns ON when the door opens and light turns OFF when the door closes.
- ON - The light turns ON and stays ON position even when the doors are all closed.

The map lights are switched ON or OFF by pressing the corresponding switches.

### **Map Light (Sun Glasses Holder)**

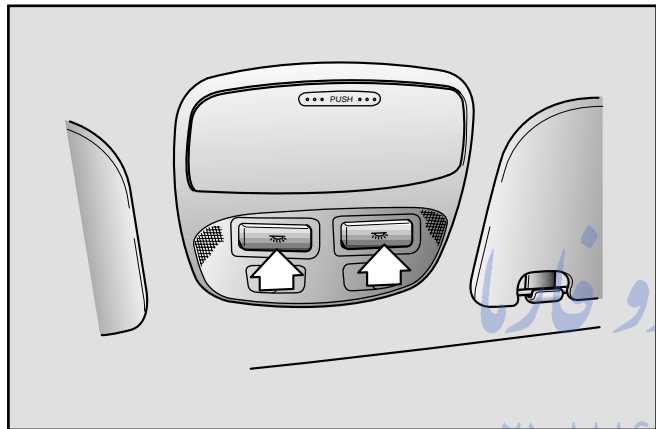

The lights are switched ON or OFF by pressing the corresponding switches.

### **Front Door Edge Warning Light (If Equipped)**

A red light comes on when the front door is opened. The purpose of this light is to assist when you get in or out and also to warn passing vehicles.

تلفن شبانه روزی: ۰۸۵-۰۲۱-۴۴۴۴۴۴۴۴  
MMSA3056

FarmaSOS.com

# Knowing Your Vehicle

## CUP HOLDER

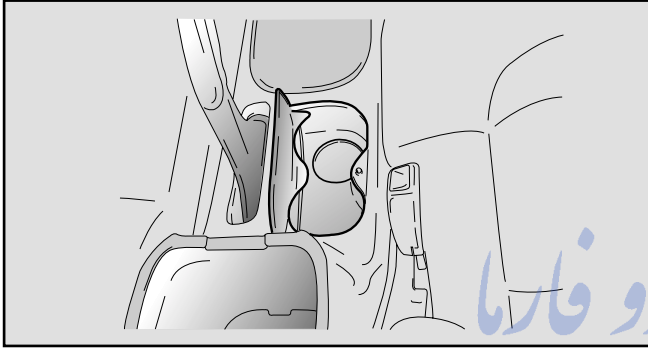

MMSA3057

The cup holder can be opened by pressing. The cover will slowly open.

### **⚠ WARNING - Hot Liquids**

- Do not place uncovered cups of hot liquid in the cup holder while the vehicle is in motion. If the hot liquid spills, you could be burned. Such a burn to the driver could cause a loss of control of the vehicle.
- To reduce the risk of personal injury in the event of a sudden stop or collision, do not place uncovered or insecure bottles, glasses, cans, etc., in the cup holder while the vehicle is in motion.

تلفن شبانه روزی: ۰۲۱-۸۸۸۶۲۰۸۵

[FarmaSOS.com](http://FarmaSOS.com)

## SUNGLASS HOLDER (IF EQUIPPED)

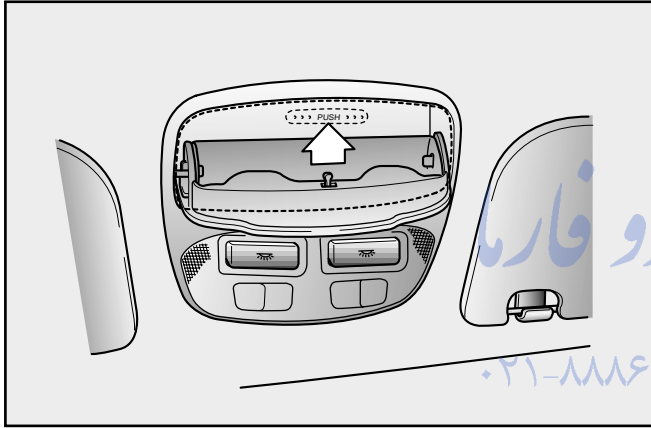

A compartment is provided at the overhead console to store sunglasses. To open the sunglass holder, press the cover and the holder will slowly open. Place your sunglasses in the compartment door with the lenses facing out.

### \* NOTICE

Close the sunglass holder while driving.

## CONSOLE STORAGE COMPARTMENT (IF EQUIPPED)

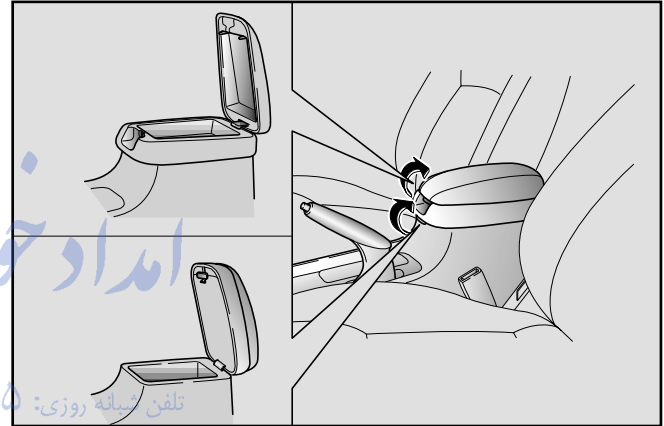

To access the console storage compartment, pull up on the locking tab at the forward end of the console lid and lift center console lid.

# Knowing Your Vehicle

## Electrical Power Outlet (If equipped)

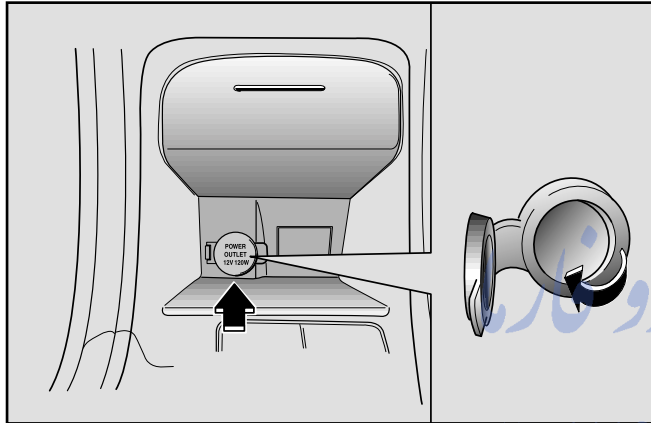

To plug in auxiliary electrical equipment, flip the outlet cover open from the edge of the cover and follow the proper installation instructions that are included with any electrical equipment you install. Maximum electrical must not exceed 10 ampere at 12 volts after engine is started.

### \* NOTICE

- Use when the engine is running, and remove a plug from the power outlet after using the electric appliance. Using when the engine stops or remaining the electric appliance with plugged in for many hours may cause the battery to be discharged.
- Adjust the air-conditioner or heater to the lowest operation level when you have to use the power socket while using air-conditioner or heater.
- If you have to use to the electrical accessories that draw higher power (vacuum cleaner, lights, cooler, etc.) only use the power outlet intermittently and with greater caution.
- Long periods of the vehicle not being started (with electrical accessories plugged in) will discharge the vehicle's battery and degrade the battery life.
- Cap the cover of power outlet when not in use.
- Some electronic devices can cause electronic interference when plugged into a vehicle's power outlet. These devices may cause excessive audio static and malfunctions in other electronic systems or devices used in your vehicle.

## SUNROOF (IF EQUIPPED)

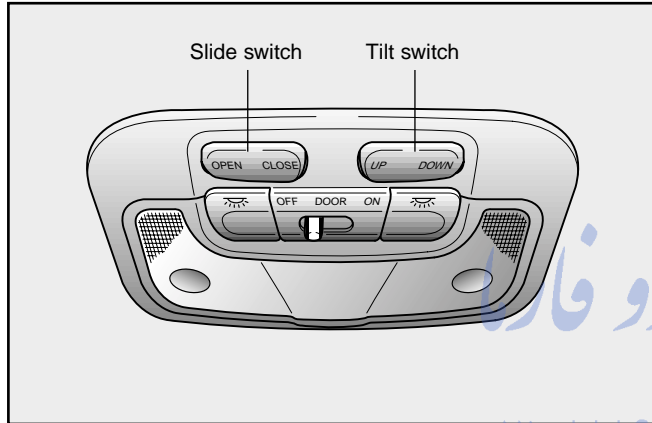

MMSA3061

Your sunroof can be opened or closed electrically when the ignition switch is in the “ON” position. You can slide or tilt the sunroof by depressing the corresponding switch located on the dome light assembly.

To tilt the sunroof, press “UP” on the tilt switch located on the dome light assembly. To close it, press “DOWN” on the tilt switch.

### • Type A

To slide the sunroof, press OPEN on the slide switch located on the dome light assembly. Hold the slide switch until the sunroof reaches the desired position then release the switch.

To close the sunroof, press CLOSE on the slide switch and hold it until it is closed completely.

### • Type B (If equipped)

To use the autoslide feature, momentarily press the “SLIDE OPEN” button on the overhead console. The sunroof will slide all the way open.

To stop the sunroof sliding at any point, press any sunroof control button.

To close the sunroof, press CLOSE on the slide switch and hold it until it is closed completely.

# Knowing Your Vehicle

## \* NOTICE

- The sunroof is made to slide together with sun shade. Make sure that sun shade is not closed when the sunroof is open.
- Release the switch button as soon as the sunroof is fully opened or closed. If kept on, the sunroof may be damaged.
- Make sure that the sunroof is fully closed when leaving the vehicle unattended.

## **⚠ WARNING -**

**Never stick your head, arms, etc. out of the sliding sunroof.**

## *Manual operation*



MMSA3062

---

If the sunroof does not operate electrically

1. Remove the rectangular plastic lens in the front of the roof panel.
2. Turn the cross bolt with a Phillips screw driver counterclockwise to remove the front dome light assembly.
3. Insert the hex head wrench (provided with the vehicle) into the socket. This wrench can be found in the glove box.
4. Turn the wrench clockwise to open or counterclockwise to close.

### ***Recalibrating the sunroof motor***

If your battery is disconnected or you manually open the sunroof using the hex head wrench, you have to re-set your sunroof motor as follows :

- Turn the ignition key to the ON position.
- Pull the sunroof fuse out of the main fuse box in engine compartment and reinstall it.
- Press CLOSE on the sunroof slide switch and hold it for 5 seconds.

#### ***CAUTION***

*If you try to open the sunroof when the temperature is below freezing or when the sunroof is covered with snow or ice the glass pane or the sunroof motor could become damaged.*

تلفن شبانه روزی: ۰۲۱-۸۸۶۲۰۸۵

maSOS.com

# Knowing Your Vehicle

## *Sunshade (if equipped)*

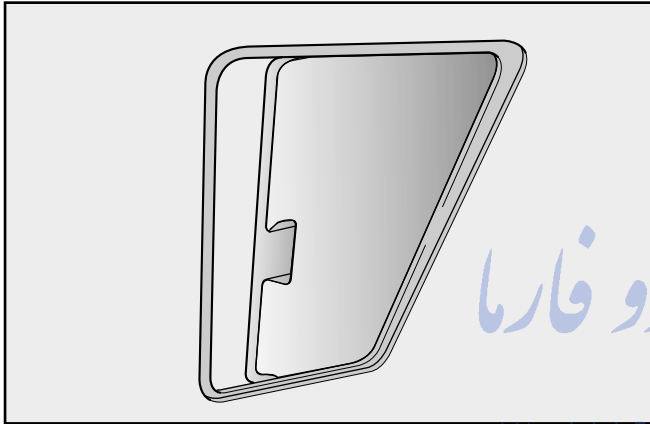

MMSA3063

The sunshade can be opened with the glass panel automatically when the glass panel is slid. But it must be closed manually.

## **ANTENNA**

### *Manual Antenna (If equipped)*

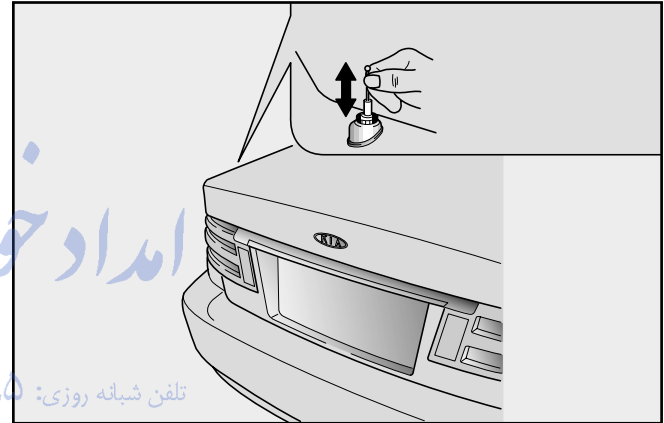

MMSA3064

Your car uses a manual stainless steel antenna to receive both AM and FM broadcast signals. Pull up the antenna using your fingers, as shown in the drawing.

### **\* NOTICE**

Before entering an automatic car wash be sure that the antenna is fully retracted.

## Power Antenna (If Equipped)

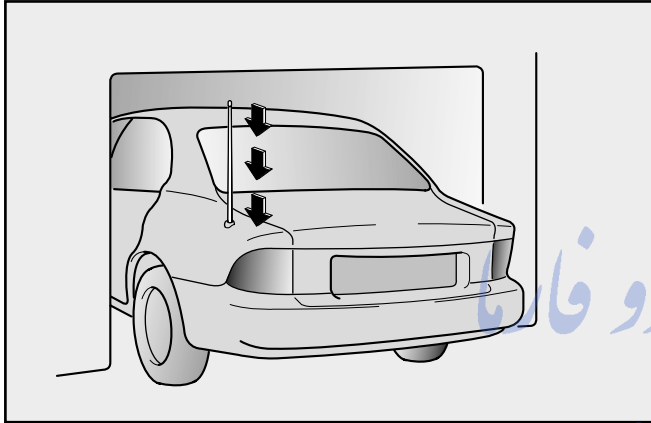

MMSA3065

The antenna will automatically be extended when the radio power switch is turned “ON” while the ignition key is either in the “ON” or “ACC” position. The antenna will automatically be retracted and stored when either the radio power switch is turned “OFF” or the ignition key is set to the “LOCK” position.

### **CAUTION**

*Before turning on the radio while stopped, make sure that no one is near the antenna.*

### **\* NOTICE**

- Before entering an automatic car wash, be sure that the antenna is retracted and stored.
- If the antenna is dirty, be sure to clean it before turning off the radio or the vehicle engine in order to prevent jamming the antenna.

# Knowing Your Vehicle

## Glass antenna (If equipped)

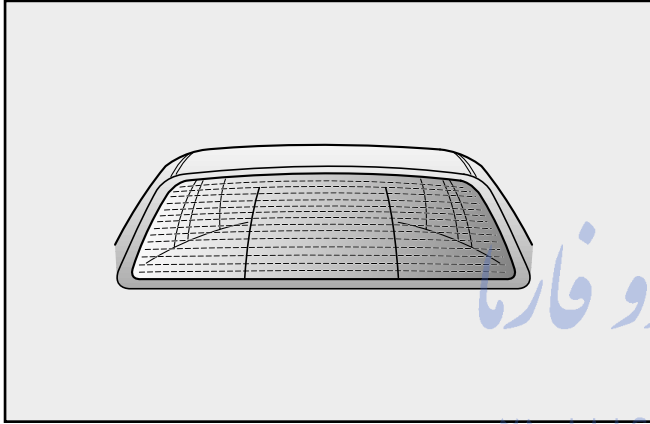

### **CAUTION**

- Do not clean the inside of the rear window glass with a cleaner or use a scraper to remove the foreign deposits as this may cause damage to the antenna elements.
- Avoid adding metallic coating such as Ni, Cd, and so on. These can disturb receiving AM and FM broadcast signals.

When the radio power switch is turned on while the ignition key is in either the "ON" or "ACC" position, your car will receive both AM and FM broadcast signals through the antenna in the rear window glass.

## LUGGAGE NET (IF EQUIPPED)

### Cargo net

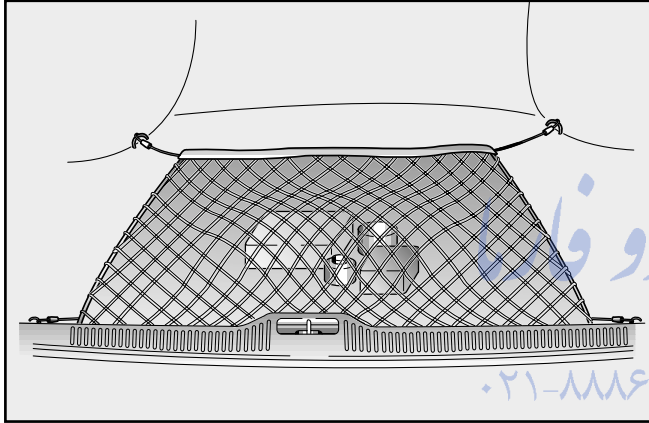

MMSA3066

To keep items from shifting in the trunk, you can use the four rings located in the trunk to attach the cargo net.

### **CAUTION**

*Do not put fragile, bulky or excessive items into cargo net. The items could be damaged.*

### **WARNING**

**Avoid eye injury. DO NOT overstretch. ALWAYS keep face and body out of recoil path. DO NOT use when strap has visible signs of wear or damage.**

تلفن شبانه روزی: ۰۲۱-۸۸۸۶۲۰۸۵

For SOS.com

---

## DRIVING YOUR VEHICLE

Ignition Switch .....	4-2
Starting the Engine .....	4-4
Manual Transaxle .....	4-6
Automatic Transaxle .....	4-9
Brake System .....	4-17
Power Steering .....	4-25
Cruise Control .....	4-26
Traction Control System .....	4-30
Instrument Cluster (Manual Transaxle) .....	4-33
Instrument Cluster (Automatic Transaxle) .....	4-34
Gauges .....	4-35
Warnings and Indicators .....	4-38
Lighting .....	4-44
Wipers and Washers .....	4-49
Rear Window Defroster .....	4-52
Hazard Warning Flasher .....	4-53
Interior Features .....	4-54
Manual Climate Control System .....	4-60
Automatic Heating and Cooling Control System ...	4-68
Windshield Defrosting and Defogging (Manual Type) .....	4-76
Windshield Defrosting and Defogging (Automatic Type) .....	4-79
Theft-Alarm System .....	4-81

# Driving Your Vehicle

## IGNITION SWITCH

### *Illuminated Ignition Switch*

Whenever a door is opened, the ignition switch will be illuminated for your convenience. The light will go off approximately 30 seconds after closing the door or when the ignition key is inserted into the ignition key cylinder.

### *Ignition Switch and Anti-Theft Steering Column Lock*

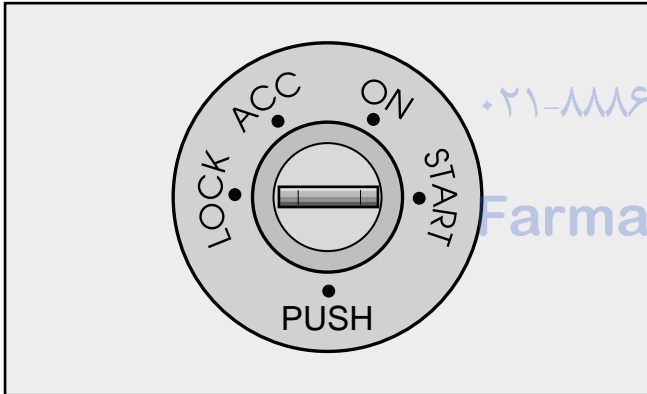

MMSA4001

## Ignition Switch Positions

### **LOCK**

The steering wheel locks to protect against theft. The ignition key can be removed only in the LOCK position. When turning the ignition switch to the LOCK position, push the key inward at the ACC position and turn the key toward the LOCK position.

### **ACC (Accessory)**

The steering wheel is unlocked and some electrical accessories, such as the radio, are operative.

### **ON**

The warning lights can be checked before the engine is started. This is the normal running position after the engine is started.

*Do not leave the ignition switch ON if the engine is not running. The battery will discharge.*

## START

Turn the ignition key to the START position to start the engine. The engine will crank until you release the key; then it returns to the ON position. The brake warning lamp can be checked in this position.

*If difficulty is experienced in turning the ignition key to the START position, turn the steering wheel right and left to release the tension and then turn the key.*

### \* NOTICE - Manual Transmission

For your safety, the engine will not start if the clutch pedal is not fully depressed.

### WARNING - Ignition Key

- It is dangerous to turn the ignition switch to LOCK or ACC while the vehicle is moving. You could lose control of steering and braking.

*(Continued)*

- The anti-theft steering column lock (if equipped) is not a substitute for the parking brake. Before leaving the driver's seat, always make sure the shift lever is engaged in 1st gear for manual transmission, or P (Park) for automatic transmission. Set the parking brake fully AND shut the engine off. If you do not take these precautions, the vehicle may move suddenly and unexpectedly. Take the ignition key with you.
- Never reach through the steering wheel for the ignition switch or any other controls while the vehicle is moving. The presence of your hand or arm in this area could cause a loss of vehicle control, an accident and serious bodily injury or fatal injury.

### Automatic Transaxle

When turning the ignition switch to the LOCK position, the shift lever must be in the P (Park) position.

### Manual Transaxle

When turning the ignition switch to the LOCK position, push the key inward at the ACC position and turn the key toward the LOCK position.

# Driving Your Vehicle

---

## STARTING THE ENGINE

1. Make sure the parking brake is applied.
2. **Manual Transmission** - Depress the clutch pedal fully and shift the transmission into Neutral. Keep the clutch pedal depressed while turning the ignition switch to the start position. The starter will not operate if the clutch pedal is not fully depressed.

**Automatic Transmission** - Place the transmission shift lever in P (Park). Depress the brake pedal fully.

*You can also start the engine when the shift lever is in the N (Neutral) position.*

3. Turn the ignition switch to START and hold it there until the engine starts (a maximum of 10 seconds), then release the key.
4. In extremely cold weather – below 0°F (–18°C) – or after the vehicle has not been operated for several days, let the engine warm up without depressing the accelerator.

*Whether the engine is cold or warm, it should be started without depressing the accelerator.*

### \* NOTICE

If the engine stalls while you are in motion, do not attempt to move the shift lever to the P (Park) position. If traffic and road conditions permit, you may put the shift lever in the N (Neutral) position while the vehicle is still moving and turn the ignition switch to the START position in an attempt to restart the engine.

### **If the engine fails to start when the engine is cold:**

The engine is “cold” when the engine coolant temperature drops below 32°F/0°C. A no-start condition may be caused by an engine that has become flooded (has excessive fuel in the cylinders). If this is the case, use the starting procedure on the following pages.

- 
1. Make sure the parking brake is applied.
  2. **Manual Transaxle** - Depress the clutch pedal fully and shift the transaxle into Neutral. Keep the clutch pedal depressed while turning the ignition switch to the start position. The starter will not operate if the clutch pedal is not fully depressed.

**Automatic Transaxle** - Place the transaxle shift lever in P (Park) or N (Neutral). Depress the brake pedal fully.

3. While fully depressing the accelerator, turn the ignition switch to the START position and hold it (a maximum of 10 seconds) to discharge the excess fuel.

If the engine starts, the engine speed will increase suddenly; release the key and the accelerator immediately.

4. If the engine has not yet started, release the accelerator after cranking the engine. Without depressing the accelerator, crank the engine until it starts (a maximum of 10 seconds).

### **If the engine fails to start when the engine is warm:**

A no-start condition, characterized by failure to restart a warmed engine despite repeated attempts may be eliminated by using the following procedure.

1. Make sure the parking brake is applied.
2. **Manual Transmission** - Depress the clutch pedal fully and shift the transmission into Neutral. Keep the clutch pedal depressed while turning the ignition switch to the start position. The starter will not operate if the clutch pedal is not fully depressed.

**Automatic Transmission** - Place the transmission shift lever in P (Park) or N (Neutral). Depress the brake pedal fully.

3. While depressing the accelerator about halfway, turn the ignition switch to the START position and hold it (a maximum of 10 seconds).
4. Permit the engine to idle for about 10 seconds before driving.

# Driving Your Vehicle

## \* NOTICE

Do not engage the starter for more than 10 seconds. If the engine stalls or fails to start, wait 5 to 10 seconds before re-engaging the starter. Improper use of the starter may damage it.

The starter will not operate if:

- Manual transaxle - the clutch pedal is not fully depressed.
- Automatic transaxle - the shift lever is NOT in the P (Park) or N (Neutral) position.

*Excessive engine noise may occur if the engine has not been operated for an extended period. The noise should stop after the engine has reached normal operating temperature. If the noise does not stop, have the vehicle inspected by an authorized Kia dealer.*

## MANUAL TRANSAXLE

### Manual Transaxle Operation (If equipped)

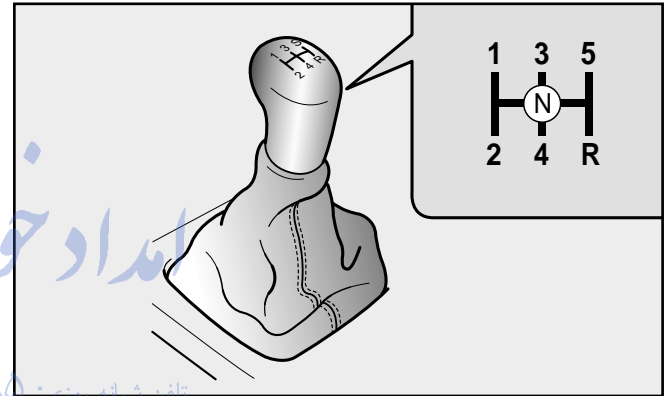

The manual transaxle has five forward gears.

Press the clutch pedal down fully while shifting, then release it slowly.

---

A special safety feature prevents inadvertent shifting from 5 (Fifth) to R (Reverse). The gearshift lever must be returned to the neutral position before shifting into R (Reverse).

*Make sure the vehicle is completely stopped before shifting into R (Reverse).*

**\* NOTICE**

To avoid premature clutch wear and damage, do not drive with your foot resting on the clutch pedal. Also, don't use the clutch to hold the vehicle stopped on an upgrade, while waiting for a traffic light, etc.

**⚠ WARNING - Manual Transaxle**

Before leaving the driver's seat, always set the parking brake fully and shut the engine off. Then make sure the transaxle is shifted into 1st gear. Unexpected and sudden vehicle movement can occur if these precautions are not followed in the order identified.

تلفن شبانه روزی: ۰۲۱ ۸۸۸۶۲۰۸۵  
FarmaSOS.com

# Driving Your Vehicle

---

## ***Recommended Shifting***

Drive the vehicle in the highest gear that allows the engine to run and accelerate smoothly without hesitating or stalling. This will give you the most efficient fuel economy and emission control.

However, never operate the engine with the tachometer (RPM) in the red area.

## ***Downshifting***

When you must slow down in heavy traffic or while driving up steep hills, downshift before the engine starts to “labor”. Downshifting reduces the chance of stalling and gives better acceleration when you again need to increase your speed. When the vehicle is traveling down steep hills, downshifting helps maintain safe speed and prolongs brake life.

امداد خودرو فارما

تلفن شبانه روزی: ۰۲۱-۸۸۸۶۲۰۸۵

FarmaSOS.com

## AUTOMATIC TRANSAXLE (IF EQUIPPED)

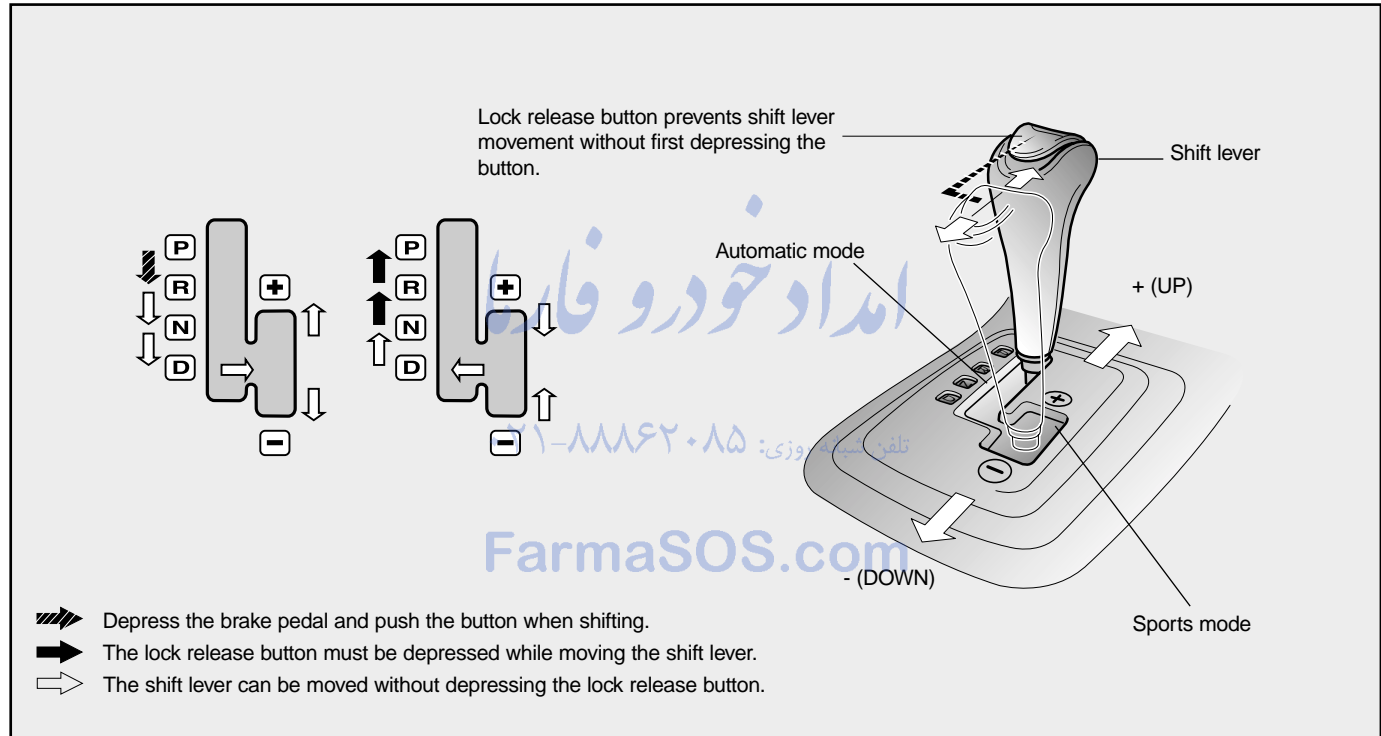

MMSA4004A

# Driving Your Vehicle

## Automatic Transaxle Operation

The optional automatic transaxle is electronically controlled.

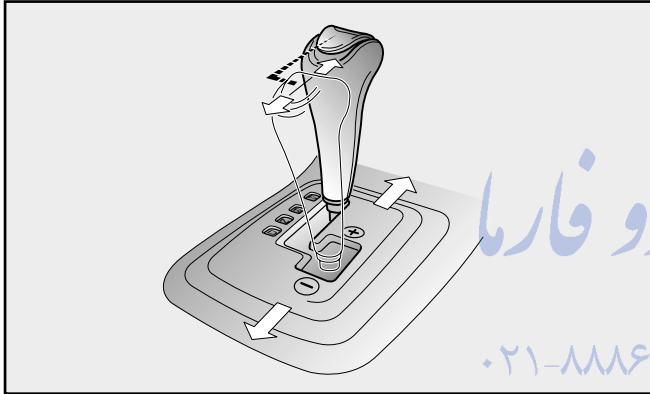

MMSA4006

All normal forward driving is done with the shift lever in the D (Drive) position.

To move the shift lever from the P (Park) position, the ignition switch must be in the ON position, the brake pedal must be depressed and the lock release button must be depressed.

*For smooth operation, depress the brake pedal when shifting from N (Neutral) to a forward or reverse gear.*

## **⚠ WARNING - Automatic Transaxle**

Before leaving the driver's seat, always make sure the shift lever is in the P (PARK) position; then set the parking brake fully and shut the engine off. Unexpected and sudden vehicle movement can occur if these precautions are not followed in the order identified.

## **\* NOTICE**

- *To avoid damage to your transaxle, do not accelerate the engine in R (Reverse) or any forward gear position with the brakes on.*
- *When stopped on an upgrade, do not hold the vehicle stationary with engine power. Use the service brake or the parking brake.*
- *Do not shift from N (Neutral) or P (Park) into D (Drive), or R (Reverse) when the engine is above idle speed.*

## ***Transaxle Ranges***

### **P (Park)**

Always come to a complete stop before shifting into P. This position locks the transaxle and prevents the front wheels from rotating. Always come to a complete stop before shifting into this position.

### **⚠ WARNING**

- **Shifting into P (Park) while the vehicle is in motion will cause the drive wheels to lock which will cause you to lose control of the vehicle.**
- **Do not use the P (Park) position in place of the parking brake. Always make sure the shift lever is latched in the P (Park) position so that it cannot be moved unless the lock release button is pushed in, AND set the parking brake fully.**

تلفن شبانه روزی: ۰۲۱-۸۸۸۶۲۰۸۵

[FarmaSOS.com](http://FarmaSOS.com)

# Driving Your Vehicle

---

- Before leaving the driver's seat, always make sure the shift lever is in the P (PARK) position. Set the parking brake fully, shut the engine off and take the key with you. Unexpected and sudden vehicle movement can occur if you do not follow these precautions in the order specified.
- Never leave a child unattended in a vehicle.

## **CAUTION**

*The transaxle may be damaged if you shift into P (Park) while the vehicle is in motion.*

## **R (Reverse)**

Use this position to drive the vehicle backward.

## **\* NOTICE**

*Always come to a complete stop before shifting into or out of R (Reverse); you may damage the transaxle if you shift into R while the vehicle is in motion, except as explained in "Rocking the Vehicle", in this manual.*

## **N (Neutral)**

With the gearshift in the N position, the wheels and transaxle are not locked. The vehicle will roll freely even if the transfer case is in gear, unless the parking brake or service brakes are applied.

---

## D (Drive)

This is the normal forward driving position. The transaxle will automatically shift through a four-gear sequence, providing the best fuel economy and power.

For extra power when passing another vehicle or climbing grades, depress the accelerator fully, at which time the transaxle will automatically downshift to the next lower gear.

For improved engine performance, the transaxle will not shift into 4th gear until the engine coolant temperature reaches approximately 155°F.

امداد خودرو فارما

تلفن شبانه روزی: ۰۲۱-۸۸۸۶۲۰۸۵

FarmaSOS.com

# Driving Your Vehicle

## Sports Mode

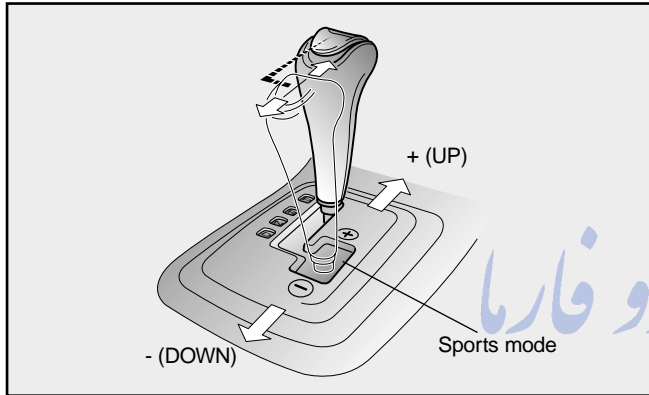

MMSA4006

Whether the vehicle is stationary or in motion, sports mode is selected by pushing the shift lever from the “D” position into the manual gate. To return to “D” range operation, push the shift lever back into the main gate.

In sports mode, moving the shift lever backwards and forwards will allow you to make gearshifts rapidly. In contrast to a manual transaxle, the sports mode allows gearshifts with the accelerator pedal depressed.

Up (+) : Push the lever forward once to shift up one gear.

Down (-) : Pull the lever backwards once to shift down one gear.

### \* NOTICE

- Upshifts do not take place automatically in sports mode. The driver must execute upshifts in accordance with road conditions, taking care to keep the engine speed below the red zone.
- In sports mode, only the four forward gears can be selected. To reverse or park the vehicle, move the shift lever to the “R” or “P” position as required.
- In sports mode, downshifts are made automatically when the vehicle slows down. When the vehicle stops, 1st gear is automatically selected.
- In sports mode, when the engine rpm approaches the red zone shift points are varied to upshift automatically.

(Continued)

(Continued)

- To maintain the required levels of vehicle performance and safety, the system may not execute certain gearshifts when the shift lever is operated.
- When driving on a slippery road, push the shift lever forward into the +(up) position. This causes the transaxle to shift into the 2nd gear which is better for smooth driving on a slippery road. Push the shift lever to the -(down) side to shift back to the 1st gear.

### ***Moving Up a Steep Grade From a Standing Start***

To move up a steep grade from a standing start, depress the brake pedal, shift the shift lever to D (Drive). Select the appropriate gear depending on load weight and steepness of the grade, and release the parking brake. Depress the accelerator gradually while releasing the service brakes.

**When accelerating from a stop on a steep hill, the vehicle may have a tendency to roll backwards.**

**Shifting the shift lever into 2 (Second Gear) while in Sport mode will help prevent the vehicle from rolling backwards.**

تلفن شبانه روزی: ۰۸۵-۸۸۸۶۲۰۲۱

FarmaSOS.com

# Driving Your Vehicle

---

## **Shift Lock System**

For your safety, the Automatic Transaxle has a shift lock system which prevents shifting the transaxle out of P (Park) unless the brake pedal is depressed.

To shift the transaxle out of P (Park):

1. Depress and hold the brake pedal.
2. Start the engine or turn the ignition to the ON position.
3. Depress the lock release button and move the shift lever.

When the ignition switch is in the ACC or LOCK position, the transaxle cannot be shifted from P (Park).

If the brake pedal is repeatedly depressed and released with the shift lever in the P (Park) position, a chattering noise near the shift lever may be heard. This is a normal condition.

Also, the ignition key cannot be removed unless the shift lever is in the P (Park) position. If the ignition switch is in any other position, the key cannot be removed.

تلفن شبانه روزی: ۰۲۱-۸۸۸۶۲۰۸۵

FarmaSOS.com

---

## BRAKE SYSTEM

### ***Power Brakes***

Your vehicle has power-assisted brakes that adjust automatically through normal usage.

In the event that the power-assisted brakes lose power because of a stalled engine or some other reason, you can still stop your vehicle by applying greater force to the brake pedal than you normally would. The stopping distance, however, will be longer. Refer to the scheduled maintenance guide for scheduled maintenance intervals.

When the engine is not running, the reserve brake power is partially depleted each time the brake pedal is applied. Do not pump the brake pedal when the power assist has been interrupted. Pump the brake pedal only when necessary to maintain steering control on slippery surfaces.

### ***In the Event of Brake Failure***

If the service brakes should fail to operate while the vehicle is in motion, you can make an emergency stop with the parking brake. The stopping distance, however, will be much greater than normal.

#### **⚠ WARNING - Parking Brake**

**Pulling on the parking brake while the vehicle is moving at normal speeds can cause a sudden loss of control of the vehicle. If you must use the parking brake to stop the vehicle, use great caution in applying the brake.**

# Driving Your Vehicle

---

## **⚠️ WARNING - Brakes**

- Do not drive with your foot resting on the brake pedal. This will create abnormally high brake temperatures, excessive brake lining and pad wear, and increased stopping distances.
- When descending a long or steep hill, shift to a lower gear and avoid continuous application of the brakes. Continuous brake application will cause the brakes to overheat and could result in a temporary loss of braking performance.
- Wet brakes may result in the vehicle not slowing down at the usual rate and pulling to one side when the brakes are applied. Applying the brakes lightly will indicate whether they have been affected in this way. Always test your brakes in this fashion after driving through deep water. To dry the brakes, apply them lightly while maintaining a safe forward speed until brake performance returns to normal.

## ***Disc Brake Wear Indicators***

Your vehicle has disc brakes.

When your front brake pads are worn and it's time for new pads, you will hear a high-pitched warning sound from your front brakes. You may hear this sound come and go or it may occur whenever you depress the brake pedal.

## **⚠️ WARNING - Brake Wear**

This brake wear warning sound means your vehicle needs service. If you ignore this audible warning, you will eventually lose braking performance, which could lead to a serious accident.

## \* NOTICE

To avoid costly brake repairs, do not continue to drive with worn brake pads. Always replace brake pads or linings as a complete front or rear axle sets.

Please remember that some driving conditions or climates may cause a brake squeal when you first apply (or lightly apply) the brakes. This is normal and does not indicate a problem with your brakes.

## Parking Brake

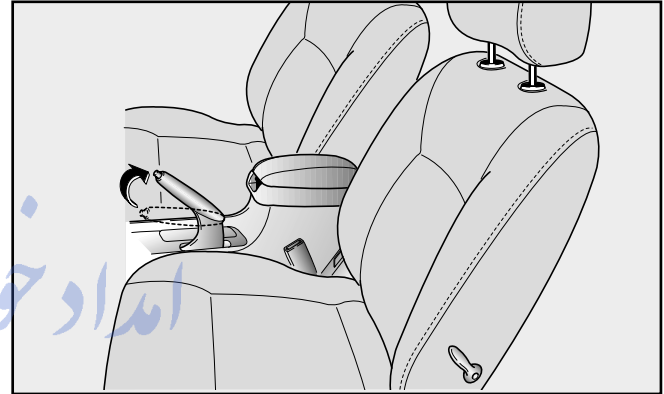

MMSA4011

- To set the parking brake, pull the parking brake handle fully and firmly upward while applying the service brake.

FarmaSOS.com

# Driving Your Vehicle

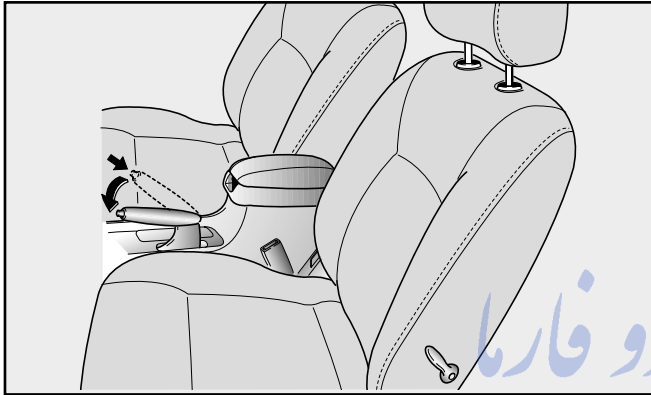

MMSA4012

- To release the parking brake, pull the handle up slightly and push the release button. Then lower the handle to the released position while holding the button in.

## **⚠ WARNING**

To prevent unintentional movement when stopped and leaving the vehicle, do not use the gearshift lever in place of the parking brake. Set the parking brake AND make sure the gearshift lever is securely positioned in 1st (First) gear or R (Reverse) for manual transaxle equipped vehicles and in P (Park) for automatic transaxle equipped vehicles.

تلفن شبانه روزی: ۰۸۵-۶۲۰۸۵-۷۷۷۷۷۷۷۷  
FarmaSOS.com

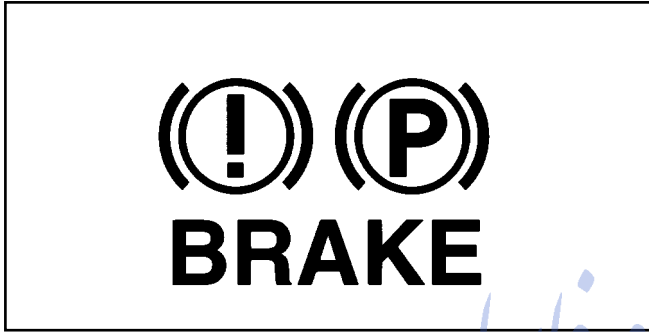

AN7B04014

Check the brake warning light each time you start the engine. This warning light will be illuminated when the engine is running and the parking brake is set.

Before driving, be sure the parking brake is fully released and the brake warning light is off.

If the brake warning light remains on after the parking brake is released, there may be a malfunction in the brake system. Immediate attention is necessary.

If at all possible, cease driving the vehicle immediately. If that is not possible, use extreme caution while operating the vehicle and only continue to drive the vehicle until you reach the first safe location or repair shop.

### ***Parking on Curbed Streets***

- When parking your vehicle on an uphill grade, park as close to the curb as possible and turn the front wheels away from the curb so that the front wheels will contact the curb if the vehicle moves backward.
- When parking your vehicle on a downhill grade, park as close to the curb as possible and turn the front wheels toward the curb so that the front wheels will contact the curb if the vehicle moves forward.

# Driving Your Vehicle

---

## ***Anti-Lock Brake System (ABS) (If equipped)***

### **⚠ WARNING - ABS Brakes**

**Your ABS is not a substitute for good driving judgement. You can still have an accident. In fact, your ABS system will probably not be able to prevent an accident in the following driving conditions:**

- **Dangerous driving, such as neglecting safety precautions, speeding, or driving too close to the vehicle in front of you.**
- **Driving at high speed in situations providing considerably less traction, such as wet conditions where hydroplaning could occur.**
- **Driving too fast on poor road surfaces. The ABS is designed to improve maximum braking effectiveness on typical highways and roads in good condition. On poor road surfaces in poor condition, the ABS may actually reduce braking effectiveness.**

The ABS system continuously senses the speed of the wheels. If the wheels are going to lock, the ABS system repeatedly modulates the hydraulic brake pressure to the wheels.

When you apply your brakes under conditions which may lock the wheels, you may hear a “tik-tik” sound from the brakes, or feel a corresponding sensation in the brake pedal. This is normal and it means your ABS system is active.

In order to obtain the maximum benefit from your ABS system in an emergency situation, do not attempt to modulate your brake pressure and do not try to pump your brakes. Press your brake pedal as hard as possible or as hard as the situation warrants and allow the ABS system to control the force being delivered to the rear brakes.

- 
- Even with the anti-lock brake system, your vehicle still requires sufficient stopping distance. Always maintain a safe distance from the vehicle in front of you.
  - Always slow down when cornering. The anti-lock brake system cannot prevent accidents resulting from excessive speeds.
  - On loose or uneven road surfaces, operation of the anti-lock brake system may result in a longer stopping distance than for vehicles equipped with a conventional brake system.

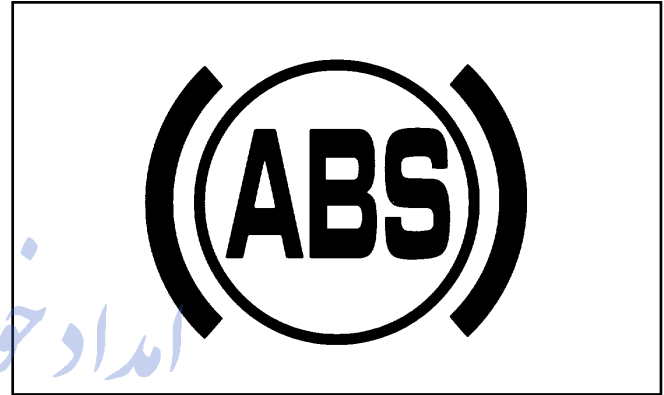

AN7B04015

تلفن شبانه روزی: ۰۲۱-۸۸۸۶۲۰۸۵

FarmaSOS.com

# Driving Your Vehicle

---

## \* NOTICE

- If the ABS warning light is on and stays on, you may have a problem with the ABS system. In this case, however, your regular brakes will work normally.
- The ABS warning light will stay on for 2-3 seconds after the engine starts. During that time, the ABS will go through self-diagnosis and the light will go off if everything is normal. If the light stays on, you may have a problem with your ABS system. Contact an authorized Kia dealer or another competent service center as soon as possible.

## \* NOTICE

- When you drive on a road having poor traction, such as an icy road, and operate your brakes continuously, the ABS will be active continuously and the ABS warning light may illuminate. Pull your car over to a safe place and stop the engine.
- Restart the engine. If the ABS warning light is off, then your ABS system is normal. Otherwise, you may have a problem with the ABS. Contact an authorized Kia dealer or another competent service center as soon as possible.

FarmaSOS.com

### **\* NOTICE**

When you jump start your vehicle because of a drained battery, the engine may not run as smoothly and the ABS warning light may blink at the same time. This happens because of the low battery voltage. It does not mean your ABS is malfunctioning.

- Do not pump your brakes!
- Have the battery recharged before driving the vehicle.

### **POWER STEERING (IF EQUIPPED)**

Power steering uses energy from the engine to assist you in steering the vehicle. If the engine is off or if the power steering system becomes inoperative, the vehicle may still be steered, but it will require increased steering effort.

Should you notice any change in the effort required to steer during normal vehicle operation, have the power steering system checked by an authorized Kia dealer or another competent service center.

### **\* NOTICE**

If the vehicle is parked for extended periods outside in cold weather (below 14 °F (-10 °C)), the power steering may require increased effort when the engine is first started. This is caused by increased fluid viscosity due to the cold weather and does not indicate a malfunction.

When this happens, increase the engine RPM to 1500rpm then release or let the engine idle for two or three minutes to warm up the fluid.

# Driving Your Vehicle

---

## \* NOTICE

- Never hold the steering wheel against a stop (extreme right or left turn) for more than five seconds with the engine running. Holding the steering wheel for more than five seconds in either position may cause damage to the power steering pump.
- If the power steering drive belt breaks or if the power steering pump malfunctions, the steering effort will greatly increase.

## CRUISE CONTROL (IF EQUIPPED)

The cruise control system allows you to program the vehicle to maintain a constant speed without resting your foot on the accelerator pedal.

With cruise control, you can set and automatically maintain any speed of more than about 25 mph (40 km/h).

## WARNING - Cruise Control

Do not use the cruise control feature under the following conditions:

- Heavy or unsteady traffic
- Slippery or winding roads
- Situations that involve varying speeds

## To set cruise control speed:

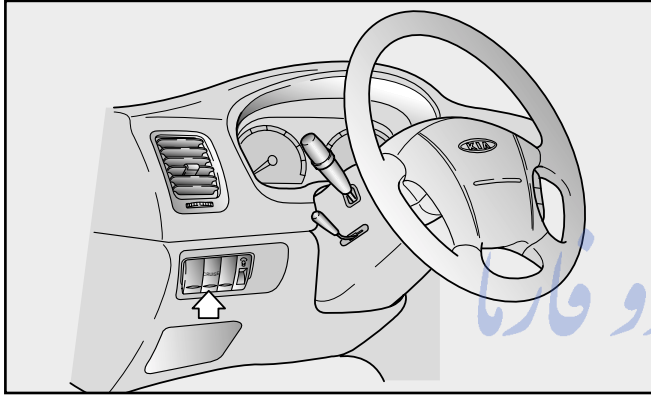

MMSA4013

1. Push in the cruise control main switch. This turns the system on.
2. Accelerate to desired cruising speed above 25 mph (40 km/h).

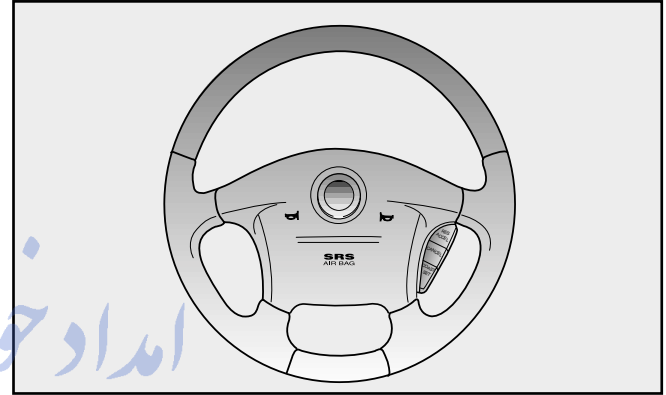

MMSA4014

3. Push the "COAST/SET" control switch and release it. The "CRUISE" indicator light in the instrument cluster will illuminate after you have set the vehicle speed at the desired speed.
4. Remove your foot from the accelerator pedal and the desired speed will automatically be maintained.
5. To increase speed, temporarily depress the accelerator pedal enough for the vehicle to exceed the preset speed. When you remove your foot from the accelerator pedal, the vehicle will return to the speed you have set.

# Driving Your Vehicle

---

## To cancel the cruise speed

*Do one of the following:*

- Depress the brake pedal.
- Depress the clutch pedal (Manual transaxle).
- Shift the shift lever to “N” position (Automatic transaxle).
- Depress the CANCEL switch located on the steering wheel.
- Decrease the vehicle speed lower than memorized speed by 12 mph (20 km/h).
- Decrease the vehicle speed approximately to less than 25 mph (40 km/h).
- Release the main switch.

## To Resume the Preset Speed

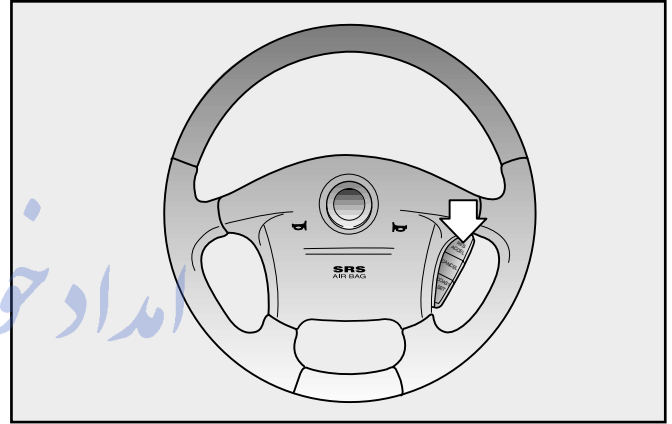

MMSA4015

The vehicle will automatically resume the speed set prior to cancellation when you press and release the RES/ACCEL switch, providing the vehicle speed is above 25 mph (40 km/h).

### ***To Reset at a Faster Speed***

1. Push the RES/ACCEL switch and hold it.
2. Accelerate to desired speed and release the RES/ACCEL switch. While the switch is pressed, the vehicle will gradually gain speed.

### ***To Reset at a Slower Speed***

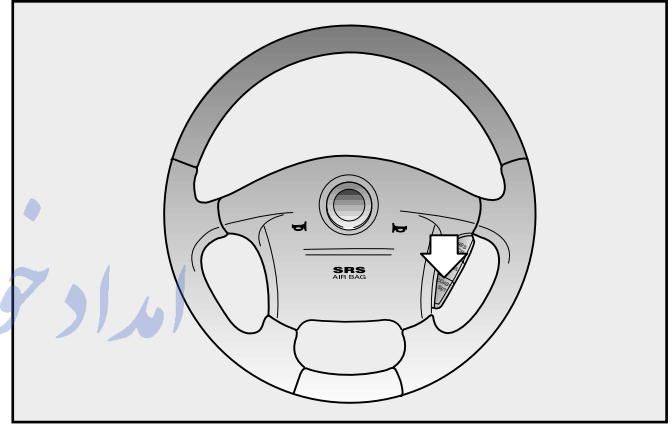

MMSA4016

1. Press the COAST/SET switch and hold it. While the switch is pressed, the vehicle speed will gradually decrease.
2. When the desired speed is obtained, release the COAST/SET switch.

# Driving Your Vehicle

## \* NOTICE

- During cruise-speed driving with a manual transaxle vehicle, do not shift into neutral without depressing the clutch pedal, since the engine will be over-revved. If this happens, depress the clutch pedal or release the main switch.
- During normal cruise control operation, when the set button is activated or reactivated after applying the brakes, the cruise control will energize after approximately 3 seconds. This delay is normal.

## TRACTION CONTROL SYSTEM (IF EQUIPPED )

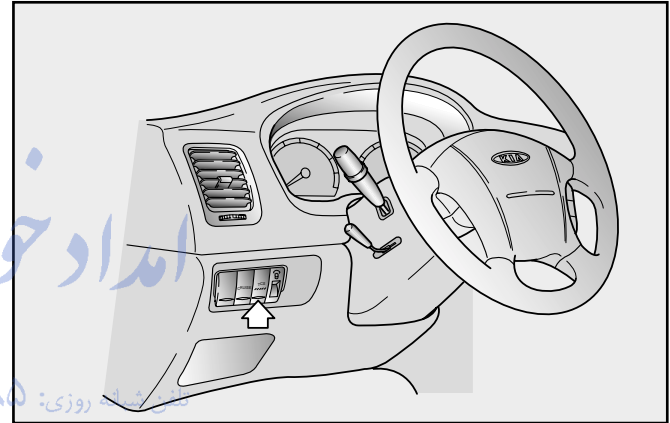

MMSA4017

On slippery road surfaces, the traction control system (TCS) limits the drive wheels from spinning excessively, thus helping the car to accelerate. It also provides improved driving force and steering performance as the car turns at accelerated speeds.

## CAUTION

*When the TCS indicator blinks, SLIP control function has been activated. It also means that the road is slippery or your car is accelerating excessively. In this situation, release foot pressure from the accelerator pedal and maintain moderate speed.*

## WARNING

**Traction control is a driving aid; all normal precautions for driving in inclement weather and on slippery road surfaces should be observed.**

## **TCS ON/OFF MODE**

In the TCS ON mode, the indicator in the instrument cluster will not be illuminated.

The indicator will illuminate when the ignition key is turned to the “ON” position, but should go off after 3 seconds. It means the TCS is in the stand-by status and at the moment of the actual operation of the TCS, the indicator will blink.

To switch to TCS OFF mode, press the TCS switch. System will be deactivated and the TCS indicator in the instrument cluster will illuminate.

If the TCS indicator stays on in the TCS ON mode, take your car to your Authorized Kia Dealer and have the system checked.

# Driving Your Vehicle

---

## \* NOTICE

- Stop the engine once. Then restart the engine, and the TCS mode will automatically turn ON.
- When the traction control is operating properly, you can feel a slight pulsation in the vehicle. This is only the effect of brake control and indicates nothing unusual.
- When the engine starts, a click is heard from the engine compartment; however, this is only the sound of traction control being checked.
- When moving out of the mud or fresh snow, pressing the accelerator pedal may not cause the engine speed to increase.

FarmaSOS.com

# INSTRUMENT CLUSTER (MANUAL TRANSAXLE)

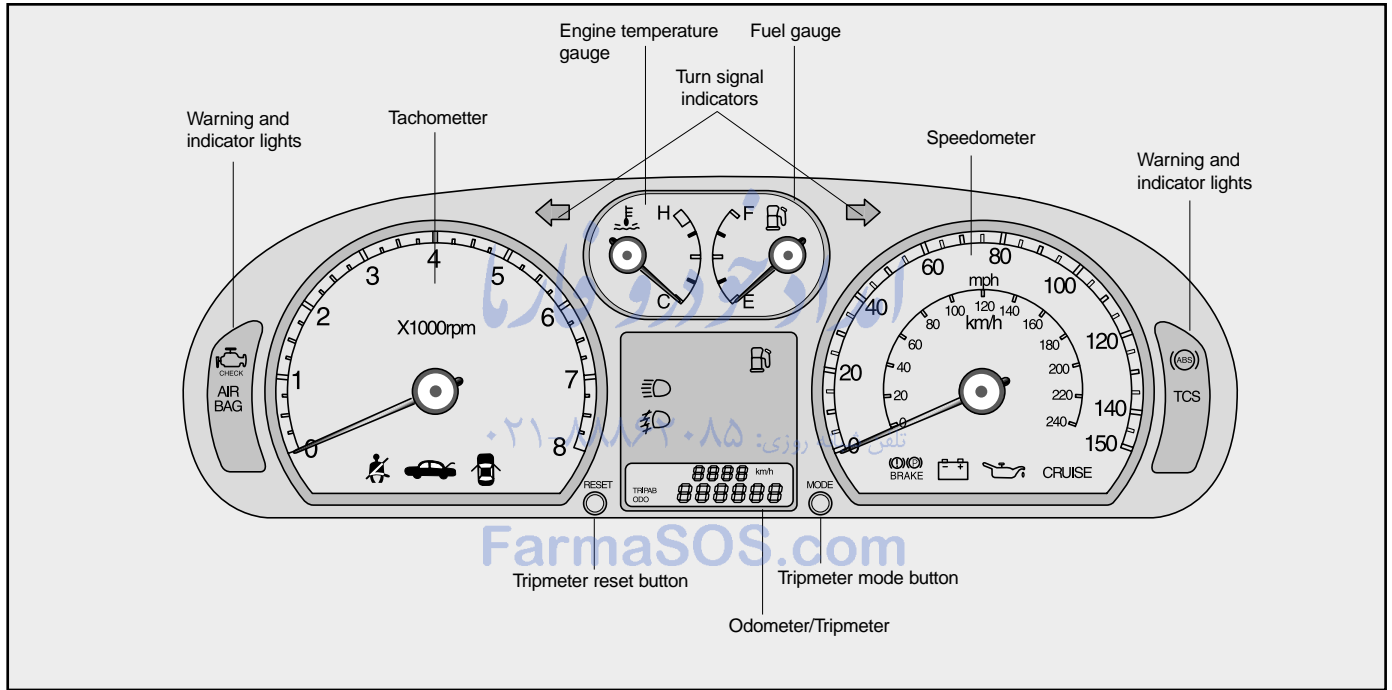

MMSA4018

# Driving Your Vehicle

## INSTRUMENT CLUSTER (AUTOMATIC TRANSAXLE)

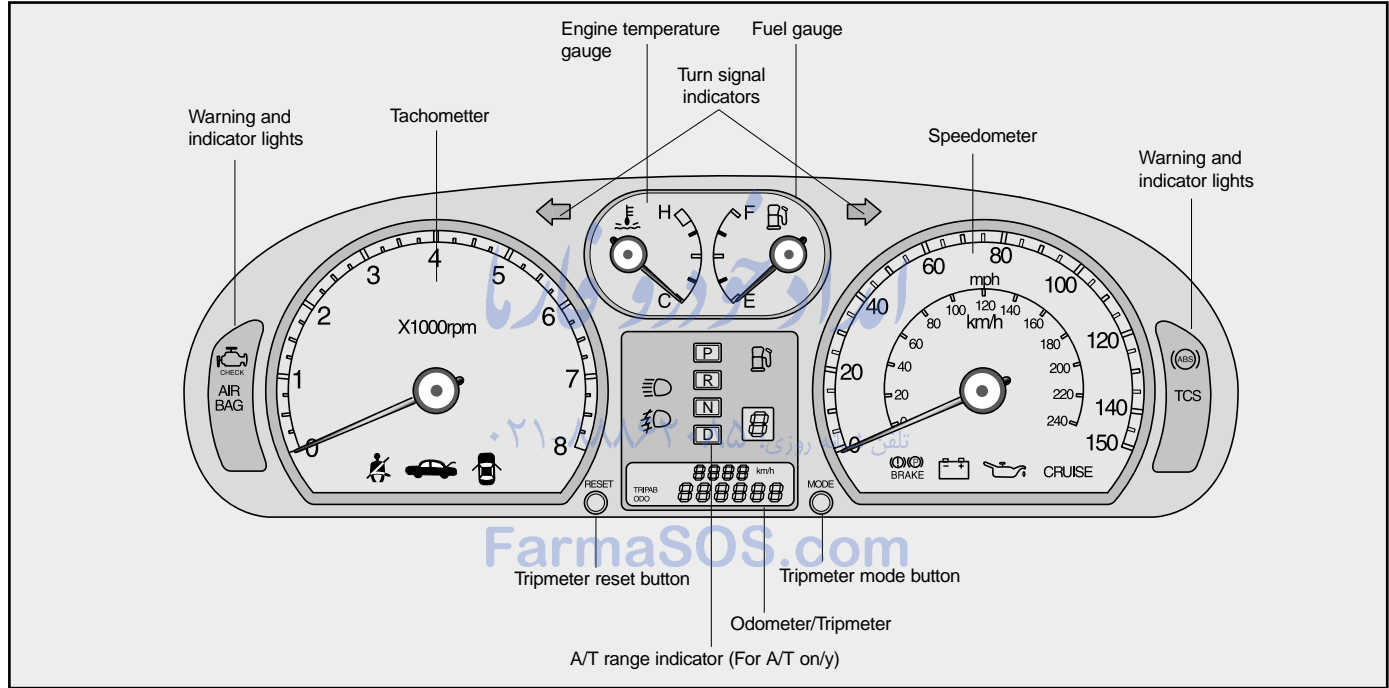

MMSA4019

## GAUGES

### **Speedometer**

The speedometer indicates the forward speed of the vehicle.

### **ODOMETER/TRIPMETER**

You can choose the odometer, tripmeter A and tripmeter B by pressing the mode selection button.

#### **Odometer**

The odometer indicates the total distance the vehicle has been driven.

#### **Tripmeter (If equipped)**

TRIP A : Tripmeter A

TRIP B : Tripmeter B

The tripmeter indicates the distance of individual trips selected by the driver. Tripmeter A and B can be reset to zero by pressing the mode selection button for one second or more then releasing.

#### **Engine Temperature Gauge**

This gauge shows the temperature of the engine coolant when the ignition switch is ON.

If the gauge pointer moves beyond the normal range area toward the H position, it indicates overheating that may damage the engine.

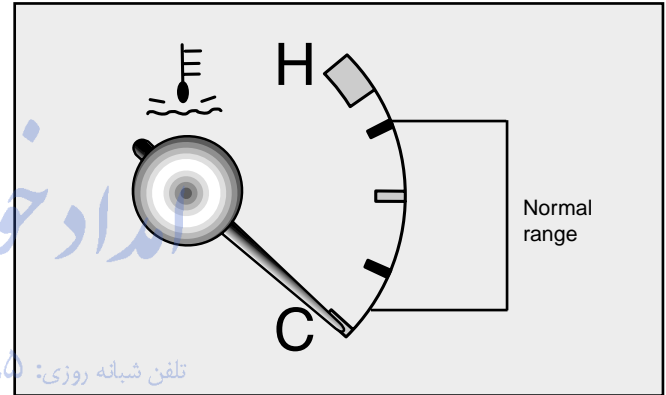

Do not continue driving with an overheated engine. If your vehicle overheats, refer to “Overheating” in the Index.

# Driving Your Vehicle

## Fuel Gauge

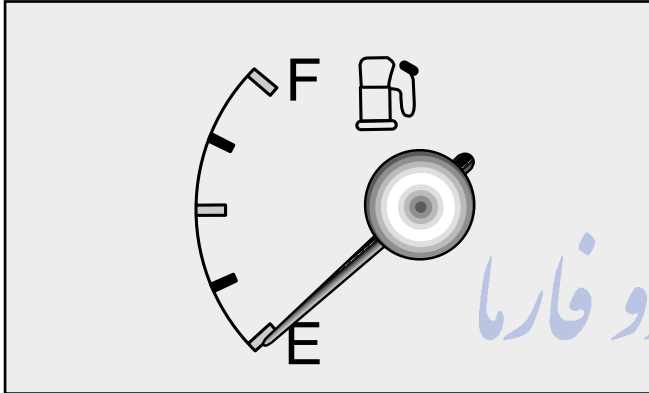

The fuel gauge indicates the approximate amount of fuel remaining in the fuel tank.

Fuel tank capacity - 16.9 gal. (65 liters).

The fuel gauge is supplemented by a low fuel warning light, which will illuminate when the fuel level has dropped to about 2.2 gal. (8.5 liters).

## Tachometer

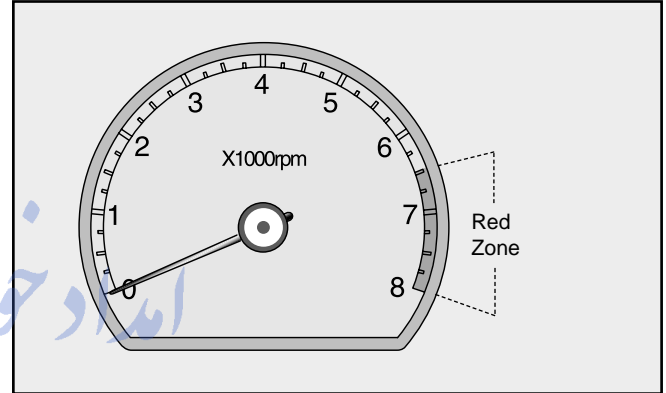

The tachometer indicates the approximate number of engine revolutions per minute (rpm).

Use the tachometer to select the correct shift points and to prevent lugging the engine and/or over-revving the engine.

The tachometer pointer may move slightly when the ignition switch is in ACC or ON position with the engine OFF. This movement is normal and will not affect the accuracy of the tachometer once the engine is running.

**\* NOTICE**

Do not operate the engine within the tachometer's RED ZONE.  
This may cause severe engine damage.

**Instrument Panel Illumination (If equipped)**

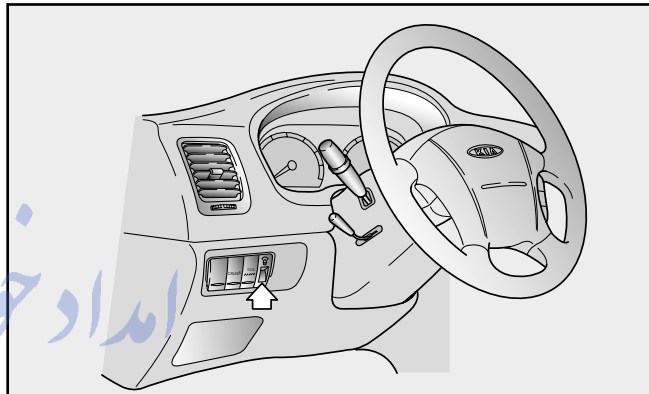

MMSA4023

When the vehicle's parking lights or headlights are on, the instrument panel lights activate. This makes the instruments and controls visible in darkness. To adjust the instrument panel illumination intensity, use the following procedure.

# Driving Your Vehicle

---

1. Depress the illumination control knob to pop it out.
2. Turn the knob up to brighten the lights or down to dim them.
3. Push the knob in after you select a brightness setting.

## WARNINGS AND INDICATORS

### *Warning Lights/Audible Indicators*

#### **Checking Operation**

All the warning lights, except the brake warning light, are checked by turning the ignition switch ON (you do not need to start the engine). Any light that does not come on should be checked by an Authorized Kia Dealer.

If the brake system warning light does not come on when the ignition switch is in the START position, have the system checked by an Authorized Kia Dealer.

After starting the engine, check to make sure that all warning lights are off. If any are still on, this indicates a situation that needs attention. When releasing the parking brake, the brake system warning light should go off.

## **Parking Brake and Brake Fluid Warning**



### **Parking Brake Warning**

This light comes ON when the parking brake is applied with the ignition switch in the START or ON position. The warning light should go off when the parking brake is released.

### **Low Brake Fluid Level Warning**

If the warning light remains ON when the parking brake is released, it may indicate that the brake fluid level in the reservoir is low. If the warning light remains ON:

1. Drive to the nearest safe location and carefully stop your vehicle.
2. With the engine stopped, check the brake fluid level immediately and add fluid as required. All brake components should also be checked immediately for fluid leaks.

3. If leaks are found, if the warning light remains on, or if the brakes do not operate properly, do not drive the vehicle. Have it towed to an Authorized Kia Dealer or other competent repair shop for a brake system inspection and necessary repairs.

### **⚠ WARNING - Brake Warning Lights**

**Driving the vehicle with a warning light ON is dangerous. If the brake warning light remains ON, have the brakes checked and repaired immediately.**

*To check bulb operation, the warning light illuminates when the ignition switch is in the ON position.*

# Driving Your Vehicle

---

## **Safety Belt Warning**



As a reminder to the driver and passenger, safety belt warning light will blink for approximately 6 seconds each time you turn the ignition switch ON.

If the driver's lap/shoulder belt is not fastened when the key is turned ON or if it is unfastened after the key is turned ON, the safety belt warning light blinks for approximately 6 seconds.

## **Safety Belt Warning Chime**

If the driver's lap/shoulder belt is not fastened when the key is turned ON or if it is unfastened after the key is turned ON, safety belt warning chime sounds for approximately 6 seconds.

## **Air Bag Warning**



This warning light will remain on for approximately 6 seconds each time you turn the ignition switch ON. If the system does not operate as described or if the light comes on while the vehicle is being driven, see an Authorized Kia Dealer or other competent repair shop for immediate assistance.

## **Charging System Warning**

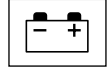

This warning light indicates a malfunction of either the generator or electrical charging system.

If the warning light illuminates while driving:

1. Drive to the nearest safe location and carefully stop your vehicle.
2. With the engine off, check the generator drive belt for looseness or breakage.
3. If the belt is adjusted properly, a problem exists somewhere in the electrical charging system. Have an Authorized Kia Dealer or other competent repair shop locate and correct the problem as soon as possible.

## **CAUTION**

*Do not drive the vehicle with a loose or broken generator belt; the engine could be damaged by overheating because this belt also drives the water pump.*

### **Engine Oil Pressure Warning**



This warning light indicates the engine oil pressure is low.

If the warning light comes on while driving:

1. Drive safely to the side of the road and stop.
2. With the engine off, check the engine oil level. If the level is low, add oil as required.

If the warning light remains on after adding oil or if oil is not available, call an Authorized Kia Dealer or other competent repair shop.

## **CAUTION**

*If the engine is not stopped as soon as possible, severe engine damage could result.*

### **Low Fuel Level warning**



This warning light indicates the fuel tank is near empty. The warning light will come on when the fuel level has dropped to about 2.2 US gal. (8.5 liters). Refuel as soon as possible.



### **Check Engine (Malfunction Indicator) Light**



This indicator light is part of the On Board Diagnostic System which monitors various emission control system components. If this light illuminates while driving, it indicates that a potential problem has been detected somewhere in the emission control system. Generally, your vehicle will continue to be driveable and will not need towing, but have the system checked by an Authorized Kia Dealer or other competent repair shop as soon as possible.

# Driving Your Vehicle

## **CAUTION**

- *Prolonged driving with the On Board Diagnostic System Malfunction Indicator Light () illuminated may cause damage to the emission control systems which could effect driveability and/or fuel economy.*
- *If the On Board Diagnostic System Malfunction Indicator Light () begins to flash ON and OFF, potential catalytic converter damage is possible which could result in loss of engine power. Have the On Board Diagnostic System inspected as soon as possible by an Authorized Kia Dealer or other competent repair shop.*

## **\* NOTICE**

A loose fuel filler cap may cause the On Board Diagnostic System Malfunction Indicator Light () in the instrument panel to illuminate unnecessarily. Always make sure that the fuel filler cap is tight.

### **Key Reminder Warning Chime**

*If the driver's door is opened and the ignition key is left in the ignition switch, the key reminder warning chime will sound. This is to remind you to remove your keys from the ignition before you lock the vehicle.*

### **Headlight High Beam Indicator**

*This indicator illuminates when the headlights are on and in the high beam position or when the turn signal lever is pulled into the Flash-to-Pass position.*

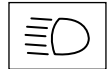

---

### **Door Ajar Warning**

This warning light comes on when a door is not closed securely with the ignition switch in any position.



### **Front Fog Indicator (if equipped)**

This light comes on when the fog lights are ON.



### **Anti-Lock Brake System (ABS) Warning Light (if equipped)**

This light illuminates when you start the engine. The light will go off if the ABS is operating normally. Also, this light comes on if the key is turned to ON, and then goes off in 2-3 seconds if the system is operating normally. If this warning light illuminates while the vehicle is being driven, have the vehicle checked by an Authorized Kia Dealer or other competent repair shop as soon as possible.



### **Cruise indicator (If Equipped)**

The cruise indicator light in the instrument cluster is illuminated only when the vehicle cruising speed has been set using the control switch. The indicator light does not illuminate when the main cruise control switch is activated.



تلفن شبانه روزی: ۸۵۰۶۲۰۸۸۴  
FarmaSOS.com

# Driving Your Vehicle

## ***Traction Control Indicator Lights (If Equipped)***

TCS

The TCS indicator will illuminate when the ignition key is turned to the "ON" position, but should go off after 3 seconds. It means the TCS is in the stand-by status and at the moment of the actual operation of the TCS, the indicator will blink.

Press the TCS switch, then the system will be deactivated and the TCS indicator will illuminate.

If the TCS indicator stays on in the TCS ON mode, take your car to your Authorized Kia Dealer and have the system checked.

## ***Trunk Lid Open Warning Light***

This light remains on unless the trunk lid is completely closed.



## **LIGHTING**

### ***Battery Saver Function***

#### **\* NOTICE**

- The purpose of this feature is to prevent the battery from being discharged. The system automatically turns off the small light when the driver removes the ignition key and opens the driver-side door.
- With this feature, the taillights will be turned off automatically if the driver parks on the side of the road at night.

If necessary, to keep the taillights on when the ignition key is removed, perform the following:

- 1) Open the driver-side door.
- 2) Turn the taillights OFF and ON again using the light switch on the steering column.

## Lighting Control

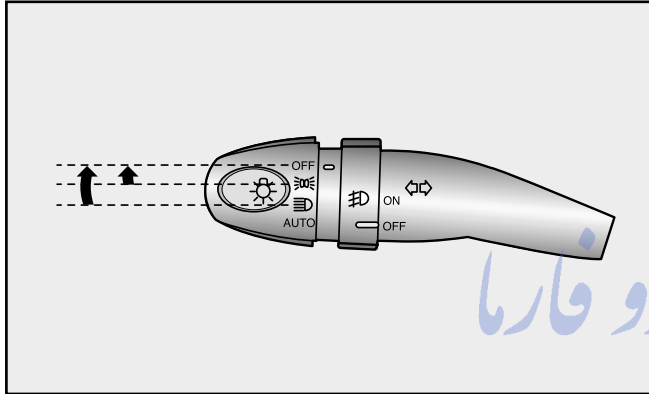

The light switch has a Headlight and a Parklight position.

To turn the lights on, twist the knob on the end of the control lever.

### Parklight position (☰☷)

When the light switch is in the parklight position, the tail, parking, license and instrument panel lights are ON.

### Headlight position (☰☷)

When the light switch is in the headlight position, the head, tail, parking, license and instrument panel lights are ON.

امداد خودرو فارما

تلفن شبانه روزی: ۰۲۱ ۸۸۶۲۰۸۵

FarmaSOS.com

# Driving Your Vehicle

## Auto light control (if equipped)

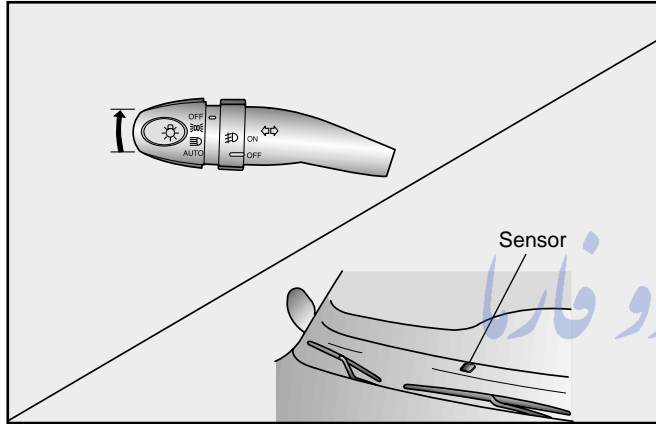

To operate the auto light, turn the knob on the end of the control lever.

If you set the knob to "AUTO" the tail lights and headlights will be turned on or off automatically according to the outside lighting conditions.

## High-Beam Operation

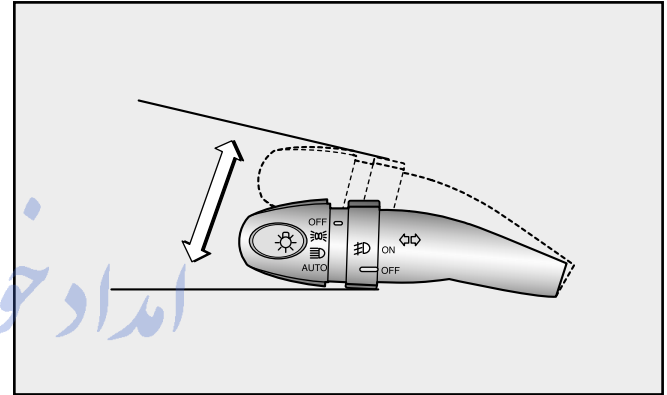

To turn on the high-beam headlights, push the lever away from you. Pull it back for low beams.

The high-beam indicator will light when the headlight high beams are switched on.

*To prevent the battery from being discharged, do not leave the lights on for a prolonged time while the engine is not running.*

## Flashing Headlights

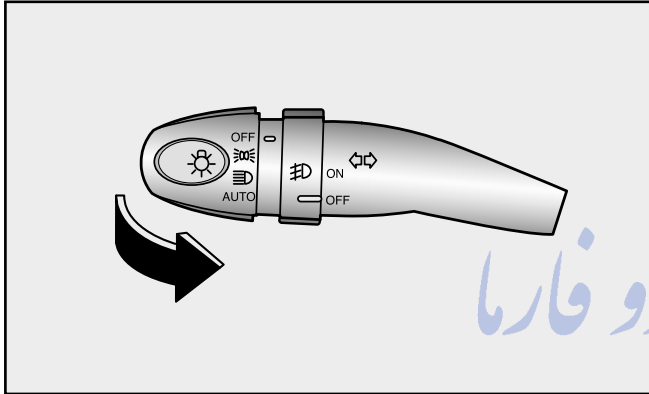

MMSA4027

To flash the headlights, pull the lever toward you. It will return to the normal position when released. The headlight switch does not need to be on to use this flashing feature.

## Turn Signals

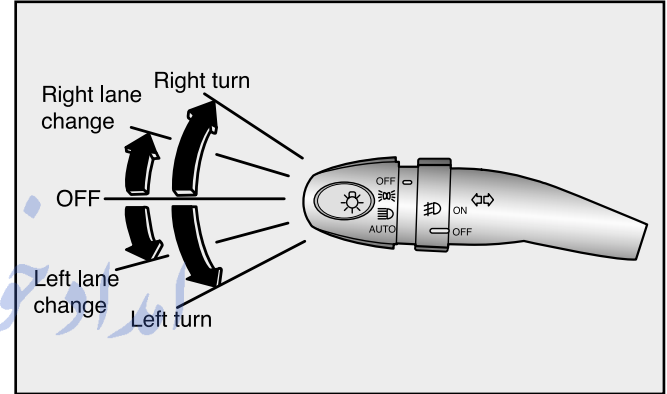

MMSA4028

The ignition switch must be on for the turn signals to function. To turn on the turn signals, move the lever up or down. Green arrow indicators on the instrument panel indicate which turn signal is operating. They will self-cancel after a turn is completed. If the indicator continues to flash after a turn, manually return the lever to the OFF (middle) position.

# Driving Your Vehicle

## Lane Change Signals

To signal a lane change, move the turn signal lever slightly and hold it in position. The lever will return to the OFF (center) position when released.

*If an indicator stays on and does not flash or if it flashes abnormally, one of the turn signal bulbs may be burned out and will require replacement.*

## Front fog light switch (IF Equipped)

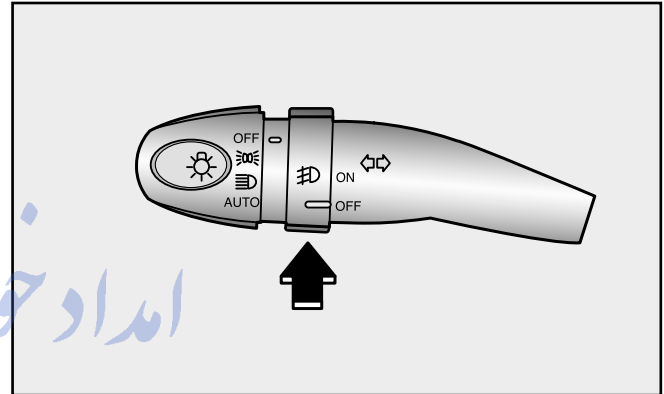

MMSA4029

To turn on the front fog lights, place the switch in the "ON" position. They will come on when the headlight switch is in the first or second position.

FarmaSOS.com

## WIPERS AND WASHERS

### Windshield Wipers

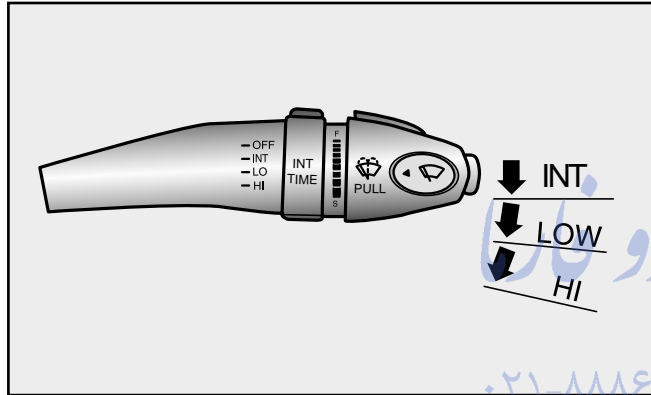

MMSA4030

The ignition switch must be ON.

To turn the wipers on, move the lever down.

INT – Intermittent wiper operation

LO – Normal wiper speed

HI – Fast wiper speed

### Variable Intermittent Wipers (If Equipped)

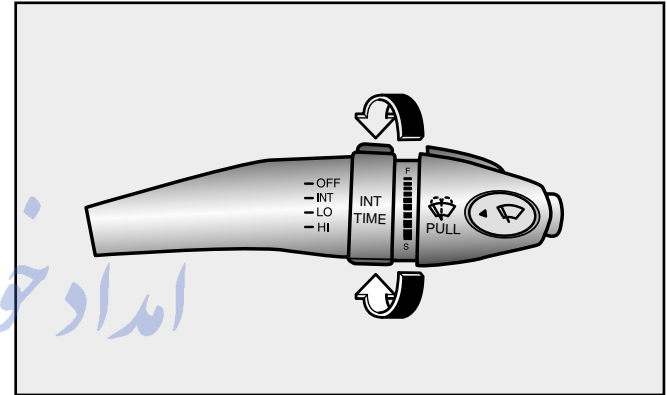

MMSA4031

Set the lever to the INT position and choose the desired wiper interval by turning the ring.

FarmaSOS.com

# Driving Your Vehicle

## One-Touch Wipers

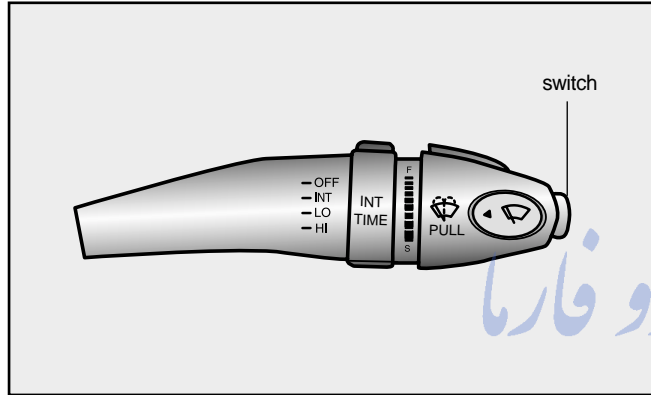

MMSA4032

For a single wiping cycle, push the lever forward and release it with the lever in the OFF position.

The wipers will operate continuously if the lever is pushed forward and held.

### \* NOTICE

- To prevent possible damage to the wipers or windshield, do not operate the wipers when the windshield is dry.
- To prevent damage to the wiper blades, do not use gasoline, kerosene, paint thinner, or other solvents on or near them.
- To prevent damage to the wiper arms and other components, do not attempt to move the wipers manually.

FarmaSOS.com

## Windshield Washers

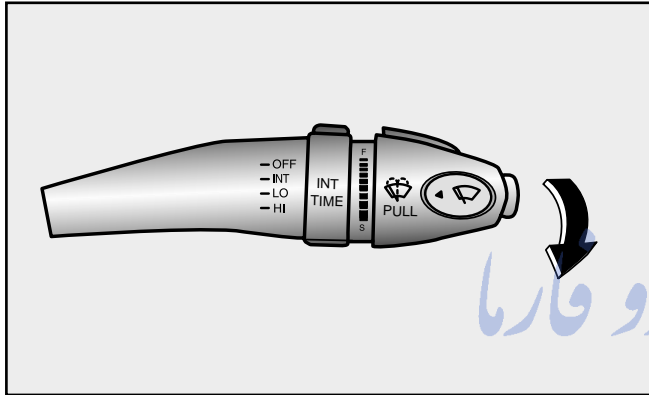

MMSA4033

In the OFF position, pull the lever gently toward you to spray washer fluid on the windshield and to run the wipers 2-3 cycles.

Use this function when the windshield is dirty.

The spray and wiper operation will continue until you release the lever.

If the washer does not work, check the washer fluid level. If the fluid level is not sufficient, you will need to add an appropriate non-abrasive windshield washer fluid to the washer reservoir. The reservoir filler neck is located in the front driver's side of the engine compartment.

### **⚠ WARNING**

**Do not use the washer in freezing temperatures without first warming the windshield with the defrosters; the washer solution could freeze on contact with the windshield and obscure your vision.**

### **\* NOTICE**

To prevent possible damage to the washer pump, do not operate the washer when the fluid reservoir is empty.

# Driving Your Vehicle

## REAR WINDOW DEFROSTER (IF EQUIPPED)

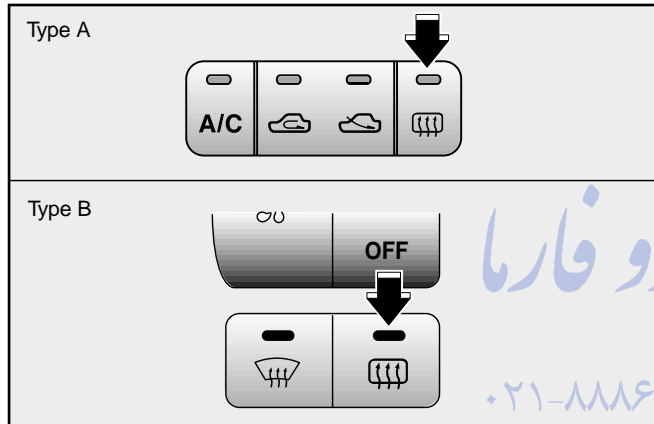

MMSA4046

The defroster heats the window to remove frost, fog and thin ice from the interior and exterior of the rear window. The ignition switch must be on for the defroster to operate.

To activate the rear window defroster, press the rear window defroster button located in the center console switch panel. The indicator on the rear window defroster button illuminates when the defroster is ON.

The rear window defroster automatically turns off after 20 minutes or when the ignition switch is turned off. To turn off the defroster, press the rear window defroster button again. If there is heavy accumulation of snow on the rear window, brush it off before operating the rear defroster.

تلفن شبانه روزی: ۰۲۱-۸۸۶۲۰۸۵

FarmaSOS.com

### \* NOTICE

To prevent damage to the conductors bonded to the inside surface of the rear window, never use sharp instruments or window cleaners containing abrasives to clean the window.

### \* NOTICE

To prevent the battery from being discharged, operate the defroster only while the engine is running.

## HAZARD WARNING FLASHER

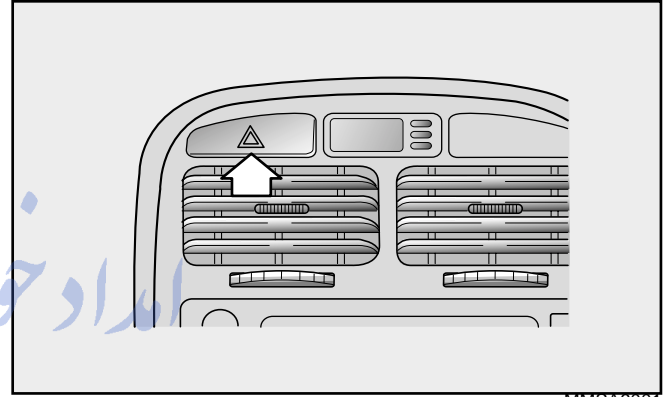

MMSA6001

The hazard warning flasher causes the rear tail lights and front turn signal lights to flash on and off, which serves as a warning to other drivers to exercise caution when approaching or passing your vehicle.

# Driving Your Vehicle

---

To activate the flasher, depress the hazard warning flasher switch. This switch operates in any ignition switch position.

To turn the flashers off, depress the switch again.

## INTERIOR FEATURES

### *Digital Clock (If equipped)*

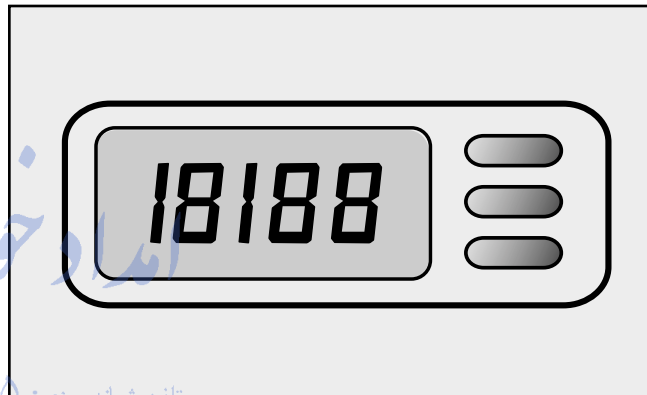

MMSA4036

When the ignition switch is in the ACC or ON position, the clock buttons operate as follows:

*A digital clock will not be installed if your vehicle comes equipped with an audio system. Vehicles equipped with an audio system already have the clock installed on the system.*

---

### **HOUR “H”:**

Pressing the “H” button with your finger, a pencil or similar object will advance the time displayed by one hour.

### **MINUTE “M”:**

Pressing the “M” button with your finger, a pencil or similar object will advance the time displayed by one minute.

### **RESET “R”:**

To clear away minutes, press the “R” button with your finger, a pencil or similar object. When you release the button, the clock will be set precisely on the hour.

For example, if the “R” button is pressed while the time is between 9:01 and 9:29, the display will be reset to 9:00. If pressed while it is between 9:30 and 9:59, the display will be reset to 10:00.

### **Cigarette Lighter**

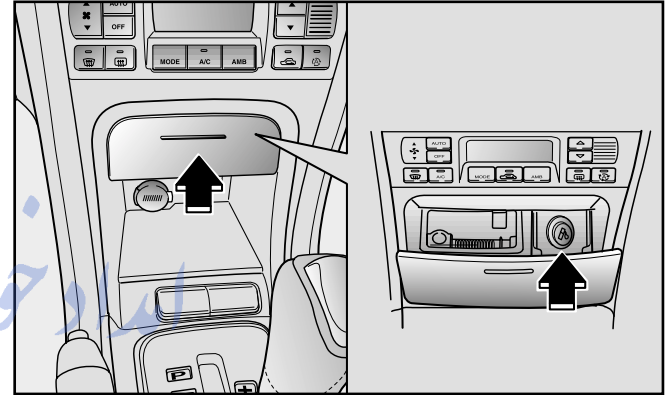

MMSA4047

To operate the cigarette lighter, press it in and release it. When it is heated, it automatically pops out ready for use. If the engine is not running, the ignition switch must be in the ACC position for the lighter to operate.

## \* NOTICE

- Do not hold the lighter in after it is already heated because it will overheat.
- Only a genuine Kia lighter or equivalent should be used in the cigarette lighter socket. The use of plug-in accessories (shavers, hand-held vacuums, and coffee pots, for example) may damage the socket or cause electrical failure.
- If the lighter does not pop out within 30 seconds, remove it to prevent overheating.

## Ashtrays

### Front Ashtray

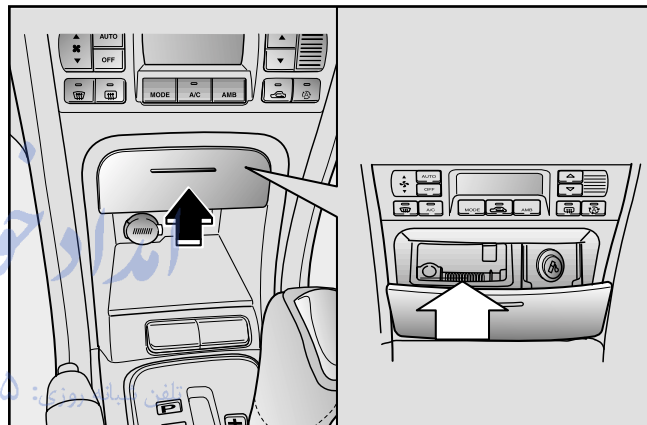

MMSA4048

To use the ashtray press the front face and the ashtray will slide out. To remove the ashtray, grasp the bucket in the ashtray, and pull it up carefully.

**⚠ WARNING - Ashtray Use**

- Do not use the vehicle's ashtrays as waste receptacles.
- Putting lit cigarettes or matches in an ashtray with other combustible materials may cause a fire.

**Rear Ashtray (If equipped)**

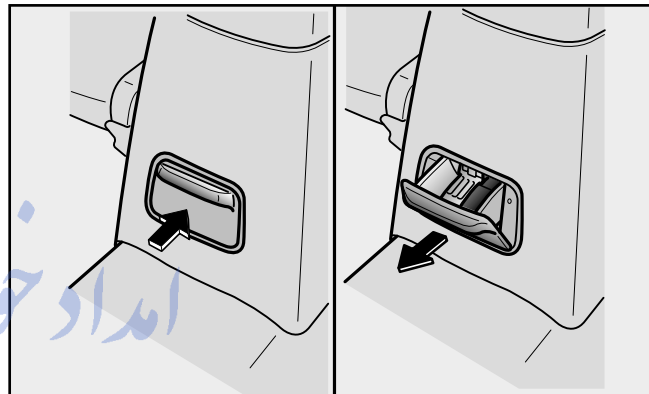

MMSA4039

To remove the rear ashtray, pull it out to the normal position, push down on the lock spring plate, and pull the ashtray out.

FarmaSOS.com

# Driving Your Vehicle

## Glove Box

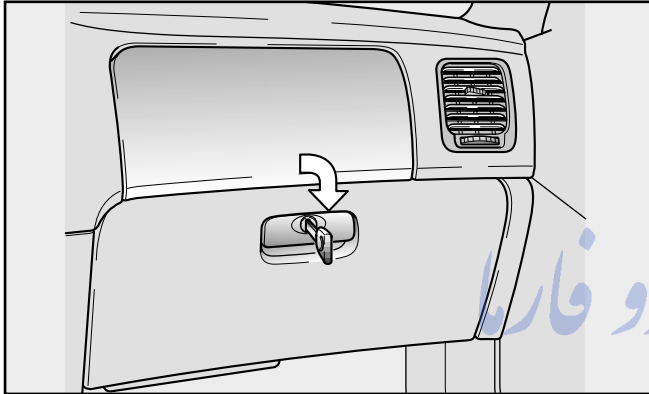

MMSA4040

To open the glove box door, pull the latch toward you. The glove box door can be locked (and unlocked) with the vehicle key.

## Door Pocket

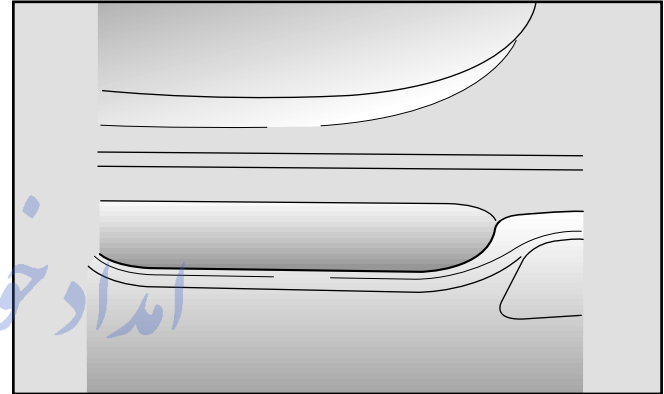

MMSA4041

Your front door pocket is a convenient place to store maps and small items.

### **⚠ WARNING**

To reduce the risk of injury in case of an accident or sudden stop, always keep the glove box door closed while driving.

## Sunvisors

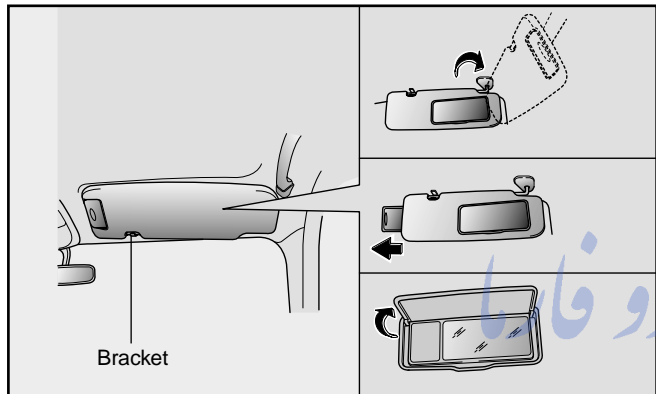

MMSA4049

To use a sunvisor, pull it downward.

To use a sunvisor for a side window (if equipped), pull it downward, unsnap it from the bracket and swing it to the side.

There is a pocket on the driver's visor for items such as tickets or notes, and a vanity mirror is provided on the passenger's visor.

Both the driver and passenger sunvisor provide important information about your vehicle's air bag system and about vehicle handling and usage.

## Vanity Mirror (Passenger Side Visor) (If equipped)

To use the vanity mirror, rotate the sunvisor downward.

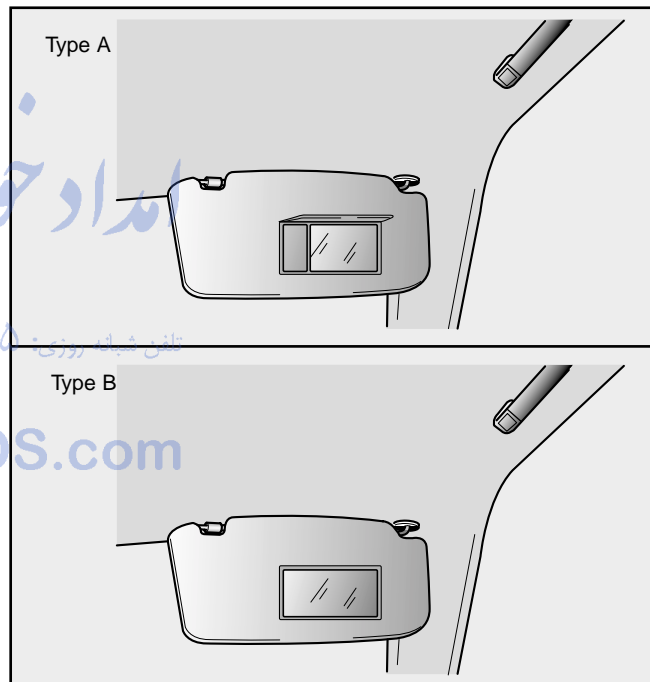

MMSA4043

# Driving Your Vehicle

## MANUAL CLIMATE CONTROL SYSTEM (IF EQUIPPED)

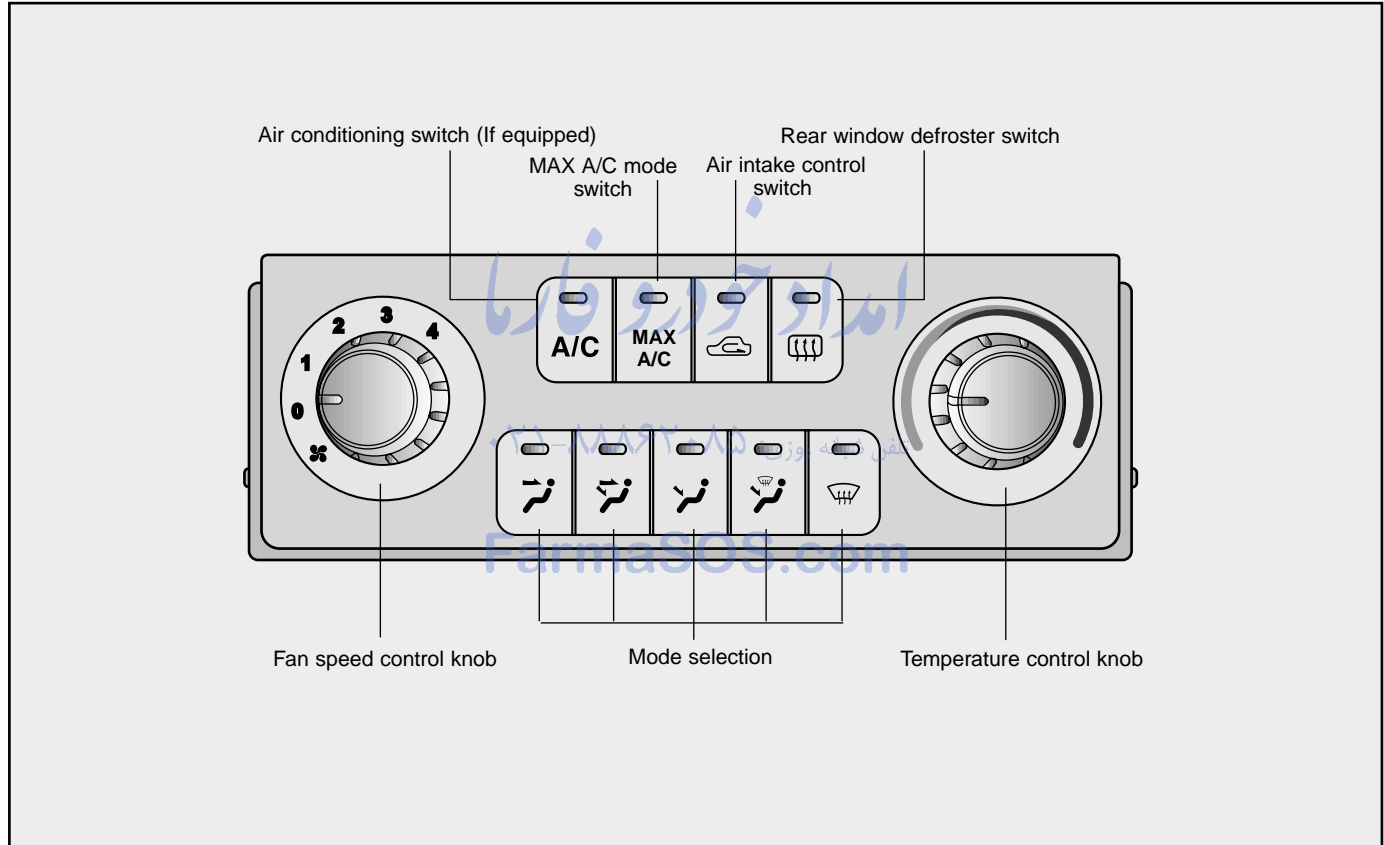

MMSA4044A

## Fan Speed Control Knob

The fan speed control knob is the knob closest to the driver. Four (4) adjustable fan speeds are provided which increase as the number increases. The ignition switch must be in the ON position for fan operation.

OFF - Fan off

- 1 - Low speed
- 2 - Medium speed
- 3 - High speed
- 4 - Maximum speed

## Mode Selection

Controls the direction of air flow through the ventilation system.

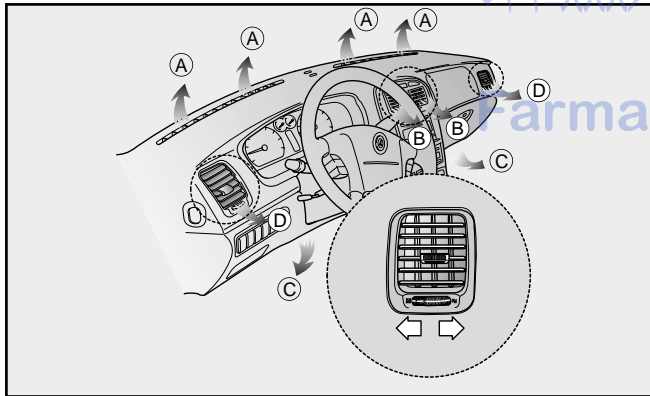

MMSA4050

The air from outlet port ④ flows at any mode. Close the ventilation outlets using the knob to block the air flow if you do not want the air.

## Face position



Air flow is directed toward the upper body and face. Additionally, each outlet can be controlled to direct the air discharged from the outlet. (outlet port: ②, ④)

## Face - floor position



Air flow is directed towards the face and the floor. The air to the floor is warmer than the air to the face

(except when the temperature control is set to the extreme cold position).

(outlet port: ②, ③, ④)

## Floor position



Most of the air flow is directed to the floor, with a small amount of the air being directed to the windshield and side window defroster.

(outlet port: ③, ④)

# Driving Your Vehicle

---

## Floor - defrost position



Most of the air flow is directed to the floor and the windshield with a small amount directed to the side window defrosters.

(outlet port: (A) , (C) , (D))

## Defrost position



Most of the air flow is directed to the windshield with a small amount of air directed to the side window defrosters.

(outlet port: (A) ,(D))

## Temperature Control Knob

The temperature control knob is the round knob closest to the passenger side of the ventilation control panel. To change the air temperature in the passenger compartment, turn the knob either clockwise for warmer air or counterclockwise for cooler air.

## Air Intake Control Switch

This is used to select fresh outside air or recirculation of the inside air.

### **WARNING**

- Continued climate control system operation in the recirculated air position may allow humidity to increase inside the vehicle which may fog the glass and obscure visibility.
- Don't sleep in a vehicle with air conditioning system on. It may cause serious harm to passenger's or death due to rare density of oxygen and drop of bodily temperature.

---

## Recirculated Air Position



When the air intake control switch is depressed (switch indicator illuminates), almost all outside air flow into the vehicle is shut off and air inside the vehicle is recirculated.

This position can be used temporarily for maximum heating or cooling (if equipped with air conditioning) and to help prevent undesirable outside air flow into the vehicle.

## Outside (Fresh) Air Position



When you select the outside (fresh) air position by pressing the air intake control switch, air enters the ventilation system from outside the vehicle. Use this position for normal ventilation and heating.

The air flow control will be set at outside (fresh) air position automatically if any of following occur.

- The ignition key is OFF.
- The fan speed control knob is OFF (0).
- When you select the floor, floor-defrost or defrost mode position.

If you want the recirculated air position, press the corresponding button.

To cancel the forced outside (fresh) air position, refer to the canceling procedure in “Windshield Defrosting and Defogging” section.

تلفن شبانه روزی: ۰۲۱-۸۵۲۰۸۵

FannaSOS.com

# Driving Your Vehicle

## Air Conditioning Switch (if equipped)

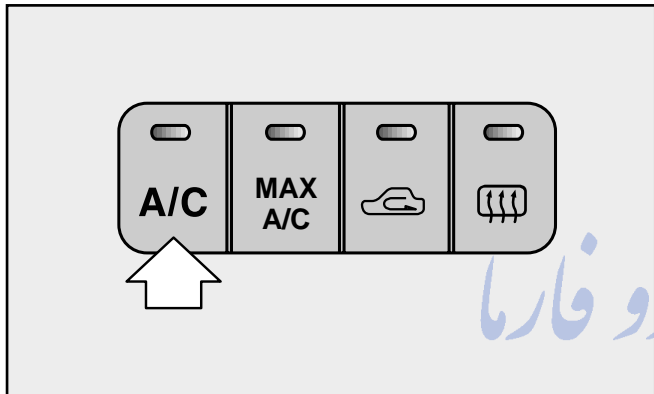

Press the switch to turn the air conditioning system on. An indicator light in the switch will illuminate when the fan switch is on indicating air conditioning system operation. Press the switch again to turn the air conditioning system off.

## MAX A/C MODE (if equipped)

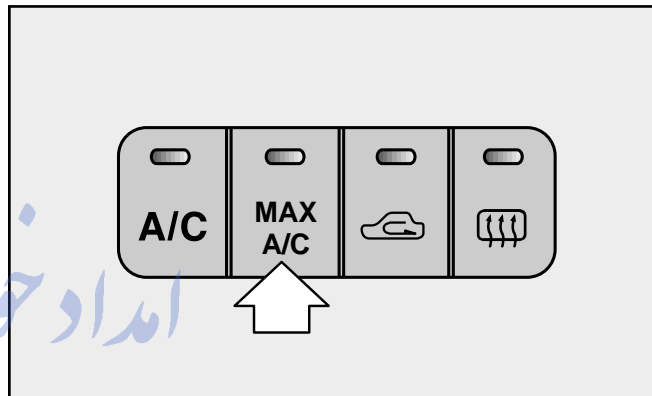

When you select the MAX A/C mode (switch indicator illuminates) while the fan speed is on, it will be set the system automatically as follows;

- the air conditioning system will be turned on.
- the recirculated air position will be selected.
- the face mode will be selected.

If you select the MAX A/C mode, you could not cancel the A/C system and the recirculated air position.

Set the fan speed control knob to desired speed and rotate the temperature control knob to the extreme left position.

To turn the MAX A/C mode off, press the MAX A/C mode button again or select the others except face mode.

## System Operation

### Ventilation



1. Set the mode selection switch to the  position.
2. Set the air intake control switch to the outside air position.
3. Set the temperature control knob to the desired position.
4. Set the fan speed control knob to the desired speed.

### Heating

1. Set the mode selection switch to the  position.
2. Set the air intake control switch to the outside (fresh) air position.

### CAUTION

*Continued climate control system operation in the recirculated air position may allow humidity to increase inside the vehicle which may fog the glass and obscure visibility.*

3. Set the temperature control knob to the desired position.
4. Set the fan speed control knob to the desired speed.
5. If dehumidified heating is desired, turn the air conditioning system (if equipped) on.
  - If cool air is desired at face level for bi-level operation, set the mode selection switch to the  position.
  - If the windshield fogs up, set the mode selection switch to the  position.

# Driving Your Vehicle

---

## Air conditioning (if equipped)

All Kia Air Conditioning Systems are filled with environmentally friendly R134a refrigerant which is not damaging to the ozone layer.

1. Start the engine. Push the air conditioning button.
2. Set the mode selection knob to the face  position.
3. Set the air intake control button to the outside air or recirculated air position.
4. Set the temperature control knob to the desired position.
5. Set the fan speed control knob to the desired speed.
6. Adjust the fan speed control knob and temperature control knob to maintain maximum comfort.

- If warmer air is desired at floor level for bi-level operation, set the mode selection knob to the  position and adjust the temperature control knob to maintain maximum comfort.
- When maximum cooling is desired, rotate the temperature control knob to the extreme left position and set the air intake control button to the recirculated air position, then set the fan speed control knob to the highest speed.

### \* NOTICE

When using the air conditioning system, monitor the temperature gauge closely while driving up hills or in heavy traffic when outside temperatures are high. Air conditioning system operation may cause engine overheating. Continue to use the blower fan but turn the air conditioning system off if the temperature gauge indicates engine overheating.

---

### ***Air Conditioning System Operation Tips***

- If the vehicle has been parked in direct sunlight during hot weather, open the windows for a short time to let the hot air inside the vehicle escape.
- To help reduce moisture inside of windows on rainy humid days, decrease the humidity inside the vehicle by operating the air conditioning system.
- During air conditioning system operation, you may occasionally notice a slight change in engine speed at idle as the air conditioning compressor cycles on. This is a normal system operation characteristics.
- Use the air conditioning system every month if only for a few minutes.
- After the use of the air conditioning system, you may notice clear water dripping (or even pudding) on the ground under the passenger side of the vehicle. This is a normal system operation characteristics.
- The air conditioning system includes a function that will automatically turns the air conditioning compressor off if engine coolant temperature approaches an over heating level. The air conditioning compressor operation will resume once engine coolant temperature returns to the normal range. Also, the air conditioning compressor automatically turns off for a few seconds when the accelerator is fully depressed.
- When operating the air conditioning system use the outside (fresh) air position.
- Operating the air conditioning system in the recirculated air position does provide maximum cooling, however, continual operation in this mode may cause the air inside the vehicle to become stale.

# Driving Your Vehicle

## AUTOMATIC HEATING AND COOLING CONTROL SYSTEM (IF EQUIPPED)

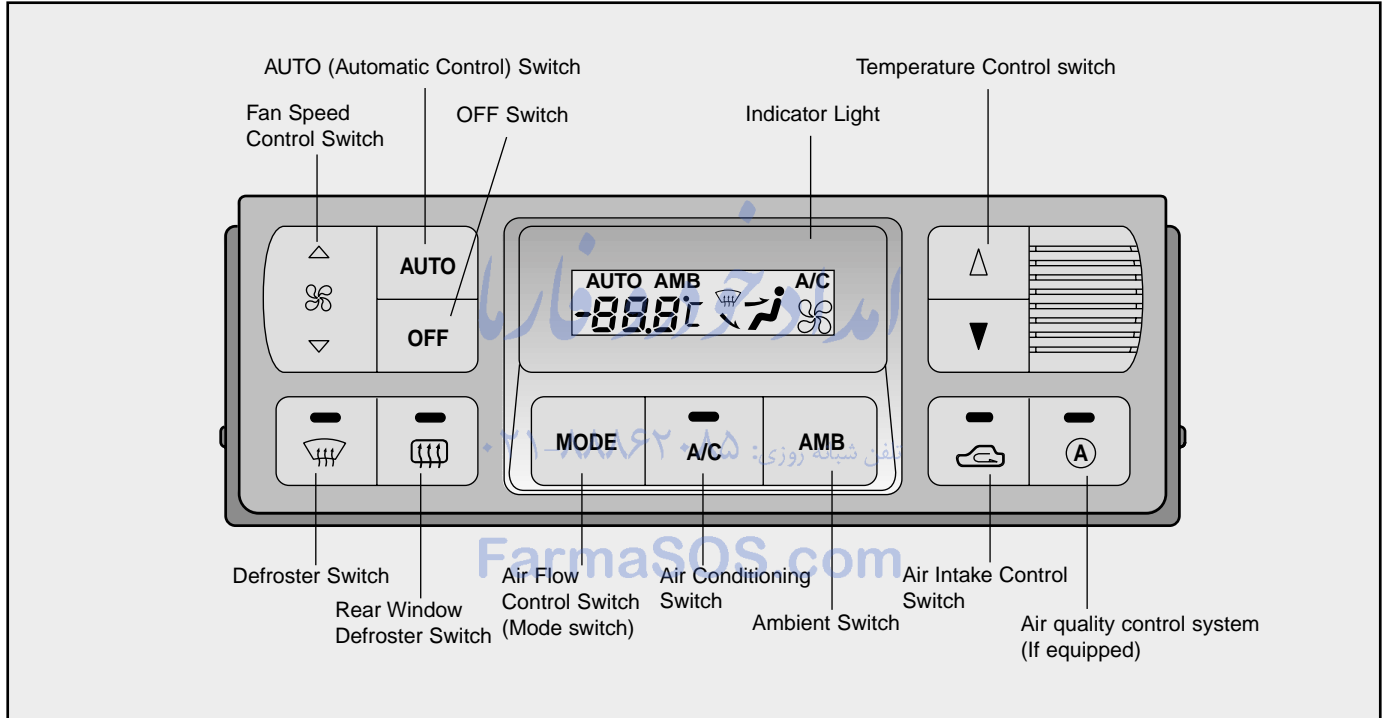

MMSA4045

Your vehicle is equipped with an automatic heating and cooling control system controlled by simply setting the desired temperature.

### ***Automatic Operation (If Equipped)***

The FATC (Full Automatic Temperature Control) system automatically controls the heating and cooling by doing as follows:

1. Push the "AUTO" switch. The indicator light will come on confirming that the Face, Floor and/ or Bi-Level modes as well as the blower speed and, air conditioner will be controlled automatically.
2. Press the "temperature control" switch to set the desired temperature. The temperature will increase to the maximum 90°F (32°C) by pressing the red button. Each time the red button is pressed the temperature will increase by 1°F (0.5°C). The temperature will decrease to the minimum 62°F (17°C) by pressing the blue button. Each time the blue button is pressed, the temperature decreases by 1°F (0.5°C).

### **\* NOTICE**

When you want to view the temperature in Fahrenheit (°F) instead of Celsius (°C) (or vise versa), while pressing the AMB button, press the temperature control (Down) button for three seconds.

# Driving Your Vehicle

---

## ***AMBIENT SWITCH***

Pressing the AMB button displays the ambient temperature on LCD.

## ***MANUAL OPERATION***

The heating and cooling system can be controlled manually as well as by pushing buttons other than the "AUTO" button. At this state, the system sequentially works according to the order of buttons selected. The function of the buttons which are not selected will be controlled automatically. Press the "AUTO" button in order to convert to automatic control of the system.

## ***Fan Speed Control***

The fan speed can be set to the desired speed by pressing the appropriate fan speed control button. The higher the fan speed is, the more air is delivered. Pressing the "OFF" button turns off the fan.

## ***Air Intake Control***

This is used to select either fresh outside air or recirculated air.

## ***Recirculated Air position***

When the air intake control switch is depressed (switch indicator illuminates), almost all outside air flow into the vehicle is shut off and air inside the vehicle is recirculated.

This position can be used temporarily for maximum heating or cooling (if equipped with air conditioning) and to help prevent undesirable outside air flow into the vehicle.

## ***Outside (Fresh) Air Position***

When the air intake control switch is not illuminated air enters the ventilation system from outside the vehicle. Use this position for normal ventilation and heating.

## Heating and Cooling System Off

Press the "OFF" button to stop the operation of the heating and cooling system.

## Air Flow Control (Mode Switch)

The mode selection button controls the direction of the air flow through the ventilation system.

The air flow outlet port is same as manual climate control system.



### Face position



Air flow is directed toward the upper body and face. Additionally, each outlet can be controlled to direct the air discharged from the outlet. (outlet port: Ⓑ , Ⓓ)

### Face - floor position



Air flow is directed towards the face and the floor. The air to the floor is warmer than the air to the face (except when the temperature control is set to the extreme cold position).

(outlet port: Ⓑ , Ⓒ , Ⓓ)

### Floor position



Most of the air flow is directed to the floor, with a small amount of the air being directed to the windshield and side window defroster.

(outlet port: Ⓒ , Ⓓ)

### Floor - defrost position



Most of the air flow is directed to the floor and the windshield with a small amount directed to the side window defrosters.

(outlet port: Ⓐ , Ⓒ , Ⓓ)

In automatic operation, the air conditioning system will automatically cycle on and the outside (fresh) air position will be selected. To cancel, press the outside (fresh) air button on the instrument panel once.

# Driving Your Vehicle

## Defrost Button



Most of the air flow is directed to the windshield with a small amount of air directed to the side window defrosters. (outlet port: Ⓐ, Ⓓ)

When the defrost button is pressed the outside (fresh) air position will automatically selected and the air will be discharged through the windshield defrost vents. The air conditioning will automatically operate based on ambient temperature. If you don't want the air-conditioning or outside (fresh) air position press the corresponding button to cancel the operation.

## Air Conditioning Button (If equipped)

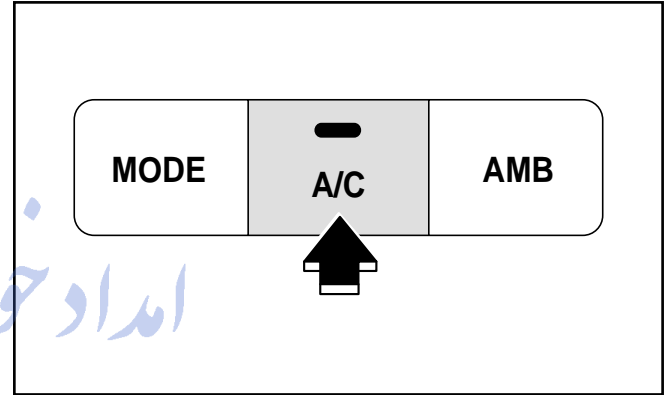

OMSA2115B

Push the A/C button to turn the air conditioning system on. The indicator light in the button will illuminate when the fan speed control knob is on. Push the button again to turn the air conditioning system off.

---

## **Air Conditioning**

All Kia Air Conditioning Systems are filled with environmentally friendly R134a refrigerant which is not damaging to the ozone layer.

1. Start the engine. Depress the air conditioning switch.
2. Set the mode selection switch to the face  position.
3. Set the air intake control switch to the outside air or the recirculated air position (switch indicator ON).
4. Set the temperature control knob (or switch) to the desired position.
5. Set the fan speed control knob (or switch) to the desired speed.
6. Adjust the fan speed control knob (or switch) and temperature control knob to maintain maximum comfort.

- If warmer air is desired at floor level for bi-level operation, set the mode selection switch to the  position and adjust the temperature control knob (or switch) to maintain maximum comfort.
- When maximum cooling is desired, set the temperature control knob (or switch) to the extreme left position and set the air intake control switch to the recirculated air position (switch indicator ON), then set the fan speed control knob to the highest speed.

### **\* NOTICE**

When using the air conditioning system, monitor the temperature gauge closely while driving up long hills or in heavy traffic when outside temperatures are high. Air conditioning system operation may cause engine overheating. Continue to use the blower fan but turn the air conditioning system off if the temperature gauge indicates engine overheating.

# Driving Your Vehicle

---

## ***Air Conditioning System Operating Tips:***

- If the vehicle has been parked in direct sunlight during hot weather, open the windows for a short time to let hot air inside the vehicle escape.
- To help reduce moisture on the inside of windows on rainy, humid days, decrease the humidity inside the vehicle by operating the air conditioning system.
- During air conditioning system operation, you may occasionally notice a slight change in engine speed at idle as the A/C compressor cycles ON. This is a normal system operating characteristic.
- Use the air conditioning system every month if only for a few minutes.
- After air conditioning system use, you may notice clear water dripping (or even puddling) on the ground under the passenger side of the vehicle. This is a normal system operating characteristic.
- The air conditioning system includes a function that will automatically turn the A/C compressor

off if engine coolant temperature approaches an overheating level.

A/C compressor operation will resume once engine coolant temperature returns to the “normal” range. Also, the A/C compressor is automatically turned off for a few seconds when the accelerator is fully depressed.

- When operating the air conditioning system use the outside (fresh) air position.
- Operating the air conditioning system in the recirculated air position does provide maximum cooling, however, continual operation in this mode may cause the air inside the vehicle to become stale.



FarmaSOS.com

### **Rear Heater Duct (if equipped)**

Whenever the ventilation controls are in the face-floor or floor position, air is directed to the rear seat passenger floor area.

### **Air Quality Control System (If equipped)**

The air inflow from the outside vehicle can be automatically controlled.

Press the (  ) button to activate the “Air Quality Control System”. To deactivate the system, press the (  ) button or air intake control button or set modes selection to (  ) position.

When using AQS mode, AQS (Air Quality Control System) automatically senses outdoor air pollutants and minimizes them from entering the vehicle, however, unpleasant or foul odors that might be present may still be noticeable within the vehicle.

### **CAUTION**

- *Prolonged driving with the “Air Quality Control System” ON will cause frosting inside the vehicle.*
- *To defrost inside the vehicle, set the mode selection to (  ) Defrost position or air intake button to the outside position.*
- *The air quality control sensor is located at the side of the radiator, be careful to avoid damaging the sensor.*

# Driving Your Vehicle

## WINDSHIELD DEFROSTING AND DEFOGGING (MANUAL TYPE)

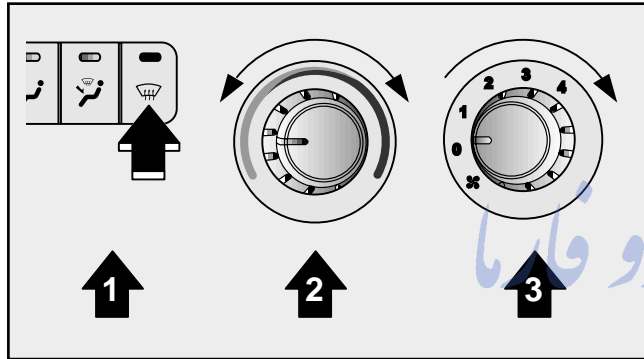

### To defog inside windshield

1. Set the mode selection switch to the or position.  
When you select or position, the system automatically turns on the outside (fresh) air mode.
2. Set the temperature control knob to the desired position.
3. Set the fan speed control knob to any desired speed except "0".  
For maximum defogging, set the fan speed control knob to the "3" or "4" position.

4-76

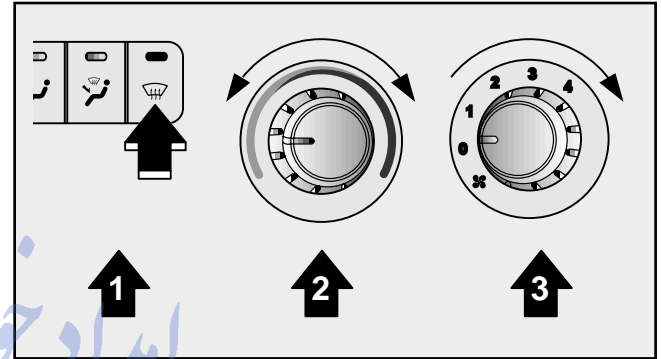



### To defrost outside windshield

1. Set the mode selection switch to the position.  
When you select position, the system automatically turns on the outside (fresh) air mode.
2. Set the temperature control knob to the extreme right/hot position
3. Set the fan speed control knob to the "3" or "4" position.

- For maximum defrosting, set the temperature control knob to the extreme right/hot position and the fan speed control knob to the highest speed.
- If warm air to the floor is desired while defrosting or defogging, set the mode selection knob to the  position.
- Before driving, clear all snow and ice from the windshield, rear window, outside rear view mirrors, and all side windows.
- Clear all snow and ice from the hood and the air inlet in the cowl grille to improve heater and defroster efficiency and to reduce the probability of fogging on the inside of the windshield.

### **WARNING**

Do not use the  or  position during cool operation in extremely humid weather. The difference between the temperature of the outside air and that of the windshield could cause the outer surface of the windshield to fog up, causing loss of visibility. In this case, set the mode selection knob to the  position and fan speed control knob to the lower speed.

### **NOTICE**

If you don't want outside (fresh) air when operating in either of these modes, air intake control switch again will deactivate the outside (fresh) air mode.

# Driving Your Vehicle

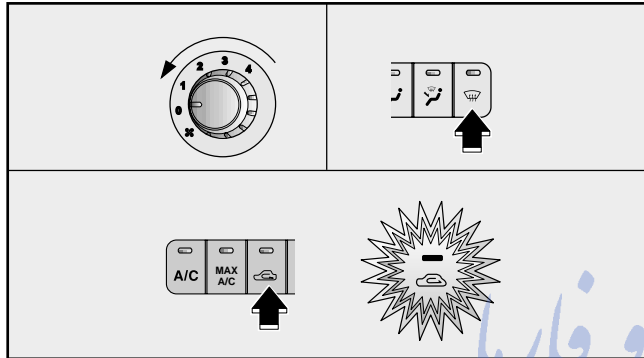

## ***How to cancel automatic the outside (fresh) air position in the Floor, Floor-Defrost and Defrost position:***

When you select the Floor, Floor-Defrost or Defrost position, the system automatically turns on the outside (fresh) air position will be selected.

If you don't want the outside (fresh) air position when operating in either of these modes, you can turn off the system operation by performing the following:

1. Make sure the engine is running or the ignition switch is in the ON position.
2. Turn the fan speed control knob to the "0" position.
3. Turn the mode selection knob to the defrost (☀️) position.
4. Push the air intake control button (👉) at least 5 times within 3 seconds.
5. Then the indicator light on the air intake control button (👉) will blink 3 times with 0.5 second intervals between blinks.

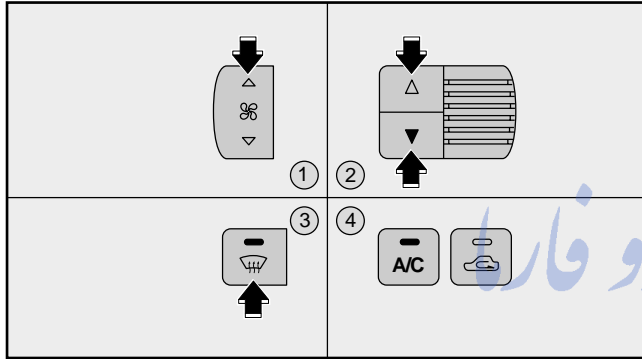

If you want to return to the automatic outside (fresh) air position, repeat the procedure above.

## WINDSHIELD DEFROSTING AND DEFOGGING (AUTOMATIC TYPE)



MMSA4055

### To Defog Inside Windshield

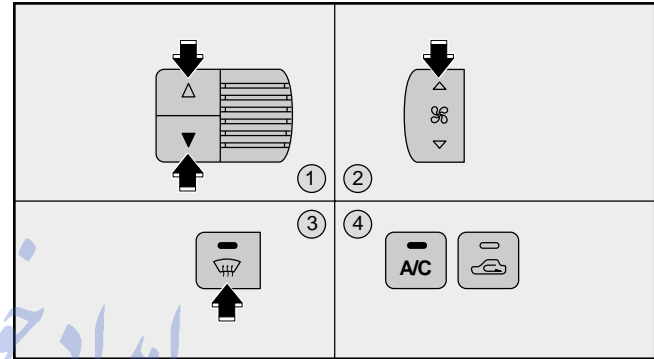

1. Select any fan speed except OFF (  ) position.
2. Select desired temperature.
3. Press the defrost button (  ).
4. The air conditioning will be turned on according to the detected ambient temperature and outside (fresh) air position will be selected.

If you don't want the air conditioning or outside (fresh) air position press the corresponding button to cancel the operation.



MMSA4056

### To Defrost Outside Windshield



1. Set temperature to the extreme hot (25°C~32°C) position.
2. Set the fan speed to the  or  position.
3. Press the defrost button (  ).
4. The air conditioning will be turned on according to the detected ambient temperature and outside (fresh) air position will be selected.

If you don't want the air conditioning or outside (fresh) air position press the corresponding button to cancel the operation.

# Driving Your Vehicle

- Before driving, clear all snow and ice from the windshield, rear window, outside rear view mirrors, and all side windows.
- Clear all snow and ice from the hood and the air inlet in the cowl grille to improve heater and defroster efficiency and to reduce the probability of fogging on the inside of the windshield.

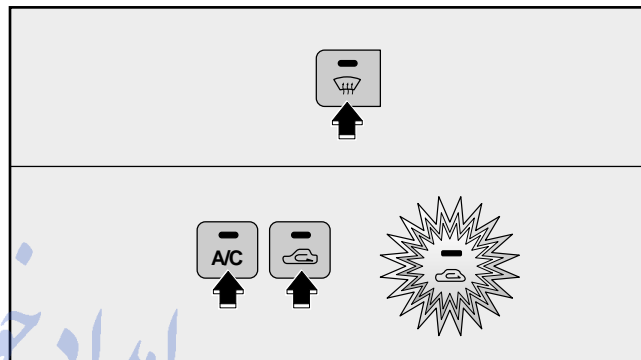

## **CAUTION**

*Do not use defrost  position during cooling operation in extremely humid weather. The difference between the temperature of the outside air and that of the windshield could cause the outer surface of the windshield to fog up, causing loss of visibility. In this case, set the mode selection knob to the  position and fan speed control knob to the lower speed.*



MMSA4057

## **How to cancel forced air conditioning operation and outside (fresh) air position in floor-defrost and defrost position ;**

1. Select the defrost position pressing defrost button ().
2. While holding the air conditioning button A/C depressed, depress the recirculated air position button () at least 5 times within 3 seconds.

The indicator light in the recirculated air position button () will blink 3 times with 0.5 second interval.

If you want to return to the automatic air conditioning system and outside (fresh) air position, repeat the same procedure.

Follow the same procedure if you want to cancel or return to the forced outside (fresh) air position when you start the engine with recirculated air position selected manually before the engine off.

## THEFT-ALARM SYSTEM (IF EQUIPPED)

### *Armed stage*

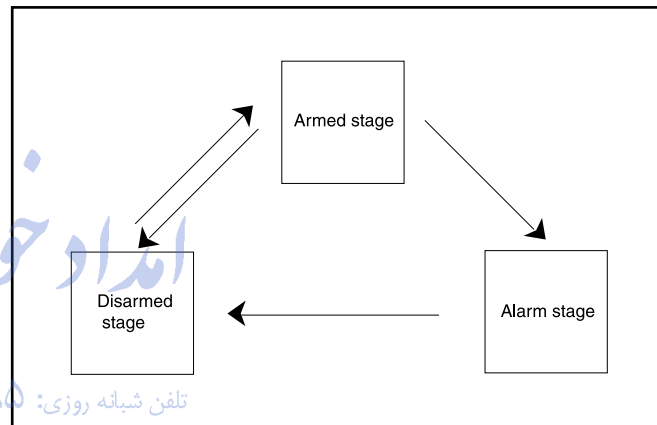

HMR.082

### **The Theft-Alarm system is armed as follows.**

- After all doors, engine hood, and trunk are locked, press the “LOCK” button on the transmitter once. The hazard flasher lights will flash once when the button is pressed, then twice when the button is released. (At this time, the alarm does not sound.)

# Driving Your Vehicle

---

## **Alarm stage**

The alarm will be activated when:

- Any door is opened without using the key or the transmitter.
- The trunk lid is opened without using the key.
- The engine hood is opened.

The alarm will sound ON for 30 seconds, then OFF for 10 seconds. This ON/OFF cycle will be repeated three times. During this time, the engine will not start.

## **Withheld alarm**

When the alarm is armed, the alarm will not sound if the trunk lid is opened with either the key or the transmitter.

However, if the trunk lid is not opened completely within two seconds after unlocking with the key or transmitter. Also, if any of the doors or hood is opened while the trunk lid is open and the alarm armed, the alarm will sound.

## **Disarmed stage**

The alarm will be deactivated when:

- The “  ” button on the transmitter is pressed.
- The ignition switch is in the “ON” position for 30 seconds or more.
- Unlock or lock the doors with the transmitter or ignition key.

### **\* NOTICE**

If the ignition key is in the ignition switch, the transmitter will not function. Avoid trying to start the engine with the alarm activated.

تلفن شبانه روزی: ۰۲۱-۸۸۸۶۲۰۸۵

FarmaSOS.com

---

## DRIVING TIPS

Fuel Requirements .....	5-2
Emission Control System .....	5-3
Tips on Driving Your Vehicle .....	5-4
Suggestions for Economical Operation .....	5-6
Special Driving Conditions .....	5-7
Trailer Towing .....	5-13
Overloading .....	5-13
Label Information .....	5-14
Homelink® Wireless Control System .....	5-16

تلفن شبانه روزی: ۰۲۱-۸۸۸۶۲۰۸۵

FarmaSOS.com

# Driving Tips

---

## FUEL REQUIREMENTS

Your new Kia vehicle must use only unleaded fuel having an octane rating of at least 87.

Your new Kia is designed to obtain maximum performance with UNLEADED FUEL, as well as minimize exhaust emissions and spark plug fouling.

### \* NOTICE

NEVER USE LEADED FUEL. The use of leaded fuel is detrimental to the catalytic converter and will damage the engine control system's oxygen sensor and affect emission control.

Never add any fuel system cleaning agents to the fuel tank other than what Kia has specified or the equivalent. (Consult an authorized Kia dealer for details.)

## *Gasoline Containing Alcohol and Methanol*

Gasohol, a mixture of gasoline and ethanol (also known as grain alcohol), and gasoline or gasohol containing methanol (also known as wood alcohol) are being marketed along with or instead of leaded or unleaded gasoline.

Do not use gasohol containing more than 10% ethanol, and do not use gasoline or gasohol containing any methanol. Either of these fuels may cause driveability problems and damage to the fuel system.

Discontinue using gasohol of any kind if driveability problems occur.

Vehicle damage or driveability problems may not be covered by the manufacturer's warranty if they result from the use of:

1. Gasohol containing more than 10% ethanol.
2. Gasoline or gasohol containing methanol.

### \* NOTICE

Never use gasohol which contains methanol. Discontinue use of any gasohol product which impairs driveability.

---

## EMISSION CONTROL SYSTEM

The emissions control system of your vehicle is covered by a written limited warranty. Please see the warranty information contained in the Warranty Information Booklet in your vehicle.

### **Vehicle Modifications**

This vehicle should not be modified. Modification of your Kia could affect its performance, safety or durability and may even violate governmental safety and emissions regulations.

In addition, damage or performance problems resulting from any modification may not be covered under warranty.

### **Engine Exhaust Gas Precautions (Carbon Monoxide)**

#### **⚠ WARNING**

**Engine exhaust gases contain carbon monoxide (CO). Though colorless and odorless, it is dangerous and could be lethal if inhaled. Follow the instructions below to avoid CO poisoning.**

- Carbon monoxide can be present with other exhaust fumes. Therefore, if you smell exhaust fumes of any kind inside your vehicle, have it inspected and repaired immediately by an authorized Kia dealer or other competent repair shop. If you ever suspect exhaust fumes are coming into your vehicle, drive it only with all the windows fully open. Have your vehicle checked and repaired immediately.
- Do not operate the engine in confined or closed areas (such as garages) any more than what is necessary to move the vehicle in or out of the area.
- When the vehicle is stopped in an open area for more than a short time with the engine running, adjust the heating or cooling system (as needed) to draw outside air into the vehicle.
- Never sit in a parked or stopped vehicle for any extended time with the engine running.
- When the engine stalls or fails to start, excessive attempts to re-start the engine may cause damage to the emission control system.

# Driving Tips

---

## ***Operating Precautions for Catalytic Converters***

### **⚠ WARNING - Fire**

**A hot exhaust system can ignite flammable items under your vehicle. Do not park the vehicle over or near flammable objects, such as dry grass, paper, leaves, etc.**

Your vehicle is equipped with a catalytic converter emission control device.

Therefore, the following precautions must be observed:

- Use only UNLEADED FUEL.
- Do not operate the vehicle when there are signs of engine malfunction, such as misfire or a noticeable loss of performance.
- Do not misuse or abuse the engine. Examples of misuse are coasting with the ignition off and descending steep grades in gear with the ignition off.

- Do not operate the engine at high idle speed for extended periods (5 minutes or more).
- Do not modify or tamper with any part of the engine or emission control system. All inspections and adjustments must be made by a qualified technician.

Failure to observe these precautions could result in damage to the catalytic converter and to your vehicle. Additionally, such actions could void your warranties.

## **TIPS ON DRIVING YOUR VEHICLE**

### ***Before Entering Vehicle:***

- Be sure that all windows, outside mirror(s), and outside lights are clean.
- Check the condition of the tires.
- Check under the vehicle for any sign of leaks.
- Be sure there are no obstacles behind you if you intend to back up.

## ***Necessary Inspections***

Fluid levels, such as engine oil, engine coolant, brake/clutch fluid, and washer fluid should be checked on a regular basis, with the exact interval depending on the fluid. Further details are provided in the “Maintenance” section

## ***Before Starting***

- Close and lock all doors.
- Position the seat so that all controls are easily reached.
- Adjust the inside and outside rearview mirrors.
- Be sure that all lights work.
- Check all gauges.
- Check the operation of warning lights when the ignition switch is turned to the ON position.
- Release the parking brake and make sure the brake warning light goes out.

For safe operation, be sure you are familiar with your vehicle and its equipment.

## **⚠ WARNING - Driving Under the Influence of Alcohol or Drugs**

**Drinking and driving is dangerous. Drunk driving is the number one contributor to the highway death toll each year. Even a small amount of alcohol will affect your reflexes, perceptions and judgement.**

**You are much more likely to have a serious if ou drink and drive.**

**If you are drinking or taking drugs, don't drive. Do not ride with a driver who has been drinking or taking drugs. Choose a designated driver or call a cab.**

**Driving while under the influence of drugs is as dangerous or more dangerous than driving drunk.**

# Driving Tips

---

## SUGGESTIONS FOR ECONOMICAL OPERATION

Your vehicle's fuel economy depends mainly on your style of driving, where you drive and when you drive.

Each of these factors affects how many miles (kilometers) you can get from a gallon (liter) of fuel. To operate your vehicle as economically as possible, use the following driving suggestions to help save money in both fuel and repairs:

- Avoid lengthy warm-up idling. Once the engine is running smoothly, begin driving. Remember, engine warm-up may take a little longer on cold days.
- Save fuel by accelerating slowly after stopping.
- Keep the engine in tune and follow the recommended periodic maintenance schedule. This will increase the life of all parts and lower your operating costs.
- Do not use the air conditioner unnecessarily.
- Slow down when driving on rough roads.
- For longer tire life and better fuel economy, always keep the tires inflated to the recommended pressures.
- Maintain a safe distance from other vehicles to avoid sudden stops. This will reduce wear on brake linings and pads. Driving in such a way will also save fuel because extra fuel is required to accelerate back to driving speed.
- Do not carry unnecessary weight in the vehicle.
- Do not rest your foot on the brake pedal while driving. This can cause needless wear, possible damage to the brakes, and poor fuel economy.
- Improper wheel alignment results in faster tire wear and lower fuel economy.

- Open windows at high speeds can reduce fuel economy.
- Fuel economy is less in crosswinds and headwinds. To help offset some of this loss, slow down when driving in these conditions.

Keeping a vehicle in good operating condition is important both for economy and safety. Therefore, have an authorized Kia dealer perform scheduled inspections and maintenance.

**⚠ WARNING - Engine off During Motion**

**Never turn the engine off while the vehicle is in motion. The power steering and power brakes will not work with the engine off. Instead of coasting downhill with the engine off, downshift to an appropriate gear for engine braking effect.**

## **SPECIAL DRIVING CONDITIONS**

### ***Hazardous Driving Conditions***

When hazardous driving conditions are encountered such as water, snow, ice, mud, sand, or similar hazards, follow these suggestions:

- Drive cautiously and allow extra distance for braking.
- Avoid sudden movements in braking or steering.
- When braking in the four-wheel drive mode (if equipped), pump the brake pedal with a light up-and-down motion until the vehicle is stopped.

**\* NOTICE**

Do not pump the brake pedal on ABS equipped vehicles.

- If stalled in snow, mud, or sand, use second gear or shift the transfer case (if equipped) into four-wheel drive. Accelerate slowly to avoid spinning the drive wheels.

# Driving Tips

---

- Use sand, rock salt, tire chains, or other non-slip material under the drive wheels to provide traction when stalled in ice, snow, or mud. (If equipped, refer to “Using Four-Wheel Drive.”)

## **⚠ WARNING - Downshifting**

**On slippery surfaces, downshifting can cause an accident. The sudden change in tire speed could cause the tires to skid. Be careful when downshifting on slippery surfaces. Try to drive slowly enough so you won't have to make any sudden changes in gear or vehicle speed.**

## ***Rocking the Vehicle***

If it is necessary to rock the vehicle to free it from snow, sand, or mud, first turn the steering wheel right and left to clear the area around your front wheels. Then, shift back and forth between 1 (First) and R (Reverse) in vehicles equipped with a manual transaxle or R (Reverse) and any

forward gear in vehicles equipped with an automatic transaxle. Do not race the engine, and spin the wheels as little as possible. If you are still stuck after a few tries, have the vehicle pulled out by a tow vehicle to avoid engine overheating and possible damage to the transaxle, transfer case (if equipped), or differential.

## **\* NOTICE**

Prolonged rocking may cause engine overheating, transaxle or transfer case (if equipped) damage or failure, and tire damage.

## **⚠ WARNING - Spinning Tires**

**Do not spin the wheels, especially at speeds more than 35 mph (56 km/h). Spinning the wheels at high speeds when the vehicle is stationary could cause a tire to overheat, explode and injure bystanders.**

---

## ***Driving at Night***

Because night driving presents many more hazards than driving in the daylight, here are some important tips to remember:

- Slow down and keep more distance between you and other vehicles, as it may be more difficult to see at night, especially in areas where there may not be any street lights.
- Adjust your mirrors to reduce the glare from other driver's headlights.
- Keep your headlights clean and properly aimed. Dirty or improperly aimed headlights will make it much more difficult to see at night.
- Avoid staring directly at the headlights of oncoming vehicles. You could be temporarily blinded, and it will take several seconds for your eyes to readjust to the darkness.

## ***Driving in the Rain***

Rain and wet roads can make driving dangerous, especially if you're not prepared for the slick

pavement. Here are a few things to consider when driving in the rain:

- A heavy rainfall will make it harder to see and will increase the distance needed to stop your vehicle, so slow down.
- Keep your windshield wiper equipment in good shape. Replace your windshield wiper blades when they show signs of streaking or missing areas on the windshield.
- If your tires are not in good condition, making a quick stop on wet pavement can cause a skid and possibly lead to an accident. Be sure your tires are in good shape.
- Turn on your headlights to make it easier for others to see you.
- Driving too fast through large puddles can affect your brakes. If you must go through puddles, try to drive through them slowly.
- If you believe your brakes may have become wet, apply them lightly while driving until normal braking operation returns.

# Driving Tips

---

## *Winter Driving*

- We recommend that you carry emergency equipment, including tire chains, a window scraper, windshield de-icer, a bag of sand or salt, flares, a small shovel and jumper cables.
- Make sure you have sufficient ethylene-glycol coolant in the radiator.
- Check the battery condition and cables. Cold temperatures reduce the capacity of any battery, so it must be in excellent condition to provide enough winter starting power.
- Make sure the engine oil viscosity is suitable for cold weather.
- Check the ignition system for loose connections and damage.
- Use antifreeze-formulated windshield washer fluid. (Do not use engine coolant antifreeze.)
- Do not use the parking brake if it might freeze. When parking, shift to 1 (First) or R (Reverse) with a manual transaxle or P (Park) with an automatic transaxle, and block the rear wheels.

## *Snow Tires*

If you mount snow tires on your Kia, make sure they are radial tires of the same size and load range as the original tires. Mount snow tires on all four wheels to balance your vehicle's handling in all weather conditions. Keep in mind that the traction provided by snow tires on dry roads may not be as high as your vehicle's original equipment tires. You should drive cautiously even when the roads are clear. Check with the tire dealer for maximum speed recommendations.

**⚠ WARNING - Snow Tire Size**  
**Snow tires should be equivalent in size and type to the vehicle's standard tires. Otherwise, the safety and handling of your vehicle may be adversely affected.**

---

*Do not install studded tires without first checking local, state and municipal regulations for possible restrictions against their use.*

### **Tire Chains**

Mount snow chains on your vehicle when warranted by driving conditions or required by local laws. Make sure the chains are the correct size for your tires. Install them only on the front tires. If metal chains are used, they must be SAE class "S". Cable-type traction devices can also be used.

### **Chain Installation**

When installing chains, follow the manufacturer's instructions and mount them as tightly as you can. Drive slowly with chains installed. If you hear the chains contacting the body or chassis, stop and tighten them. If they still make contact, slow down until it stops. Remove the chains as soon as you begin driving on cleared roads.

### **⚠ WARNING - Tire Chains**

- The use of chains may adversely affect vehicle handling.
- Do not exceed 30 mph (50 km/h) or the chain manufacturer's recommended speed limit, whichever is lower.
- Drive carefully and avoid bumps, holes, sharp turns, and other road hazards, which may cause the vehicle to bounce.
- Avoid sharp turns or locked-wheel braking.
- Do not attempt to use a tire chain on the compact spare tire because it may impair vehicle handling and result in damage to the vehicle and to the tire.
- Chains that are the wrong size or improperly installed can damage your vehicle's brake lines, suspension, body and wheels.
- Stop driving and retighten the chains any time you hear them hitting the vehicle.

# Driving Tips

---

## ***Driving in Flooded Areas***

Avoid driving through flooded areas unless you are sure the water is no higher than the bottom of the wheel hub. Drive through any water slowly. Allow adequate stopping distance because brake performance may be affected.

After driving through water, dry the brakes by gently applying them several times while the vehicle is moving slowly.

امداد خودرو فارما

تلفن شبانه روزی: ۰۲۱-۸۸۸۶۲۰۸۵

FarmaSOS.com

---

## TRAILER TOWING

We do not recommend using this vehicle for trailer towing.

## Overloading

### **⚠ WARNING - Weight Rating**

The gross axle weight rating (GAWR) and the gross vehicle weight rating (GVWR) for your vehicle are on the manufacturer's label attached to the driver's door.

Exceeding these ratings can cause an accident or vehicle damage. You can calculate the weight of your load by weighing the items (or people) before putting them in the vehicle. Be careful not to overload your vehicle.

فارما سو اس  
۰۲۱-۸۸۸۶۲۰۸۸  
FarmaSOS.com

# Driving Tips

## Label Information

### Vehicle Identification Number (VIN)

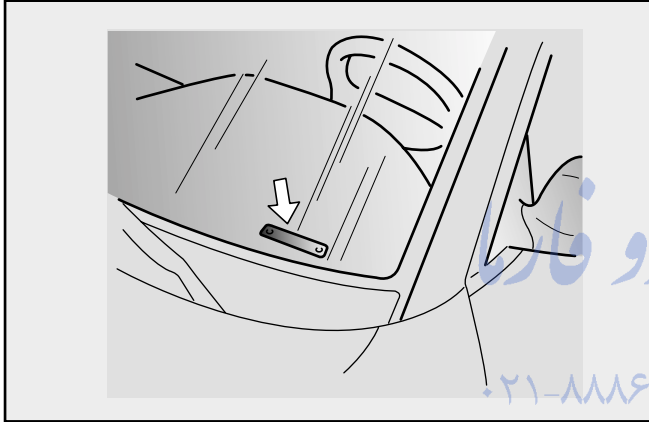

S2BLD304

This is the legal identifier for your vehicle. It appears on a plate attached to the left side of the forward portion of the dashboard. The VIN plate can be easily seen from the outside of the vehicle through the windshield on the driver's side.

### Vehicle Certification Label (MVSS Label)

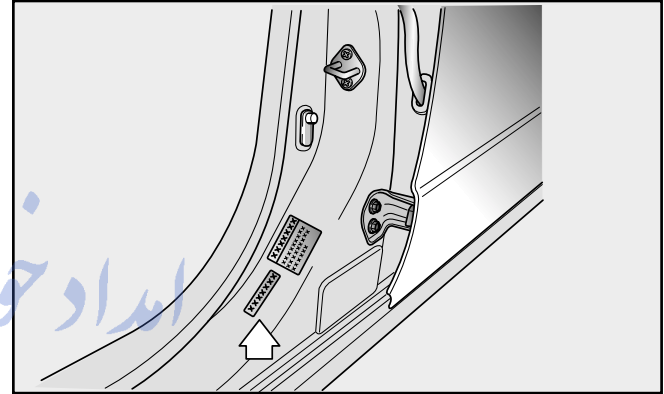

S2BLC502

The VIN also appears on the vehicle's certification label and VIN label on the pillar.

## Chassis Number

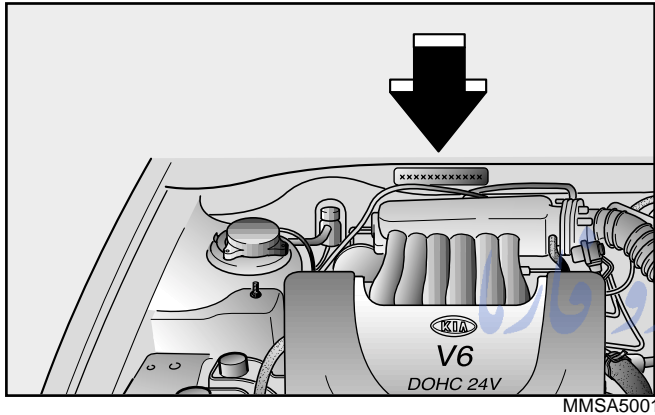

MMSA5001

## Vehicle Emission Control Information/Vacuum Hose Routing Diagram

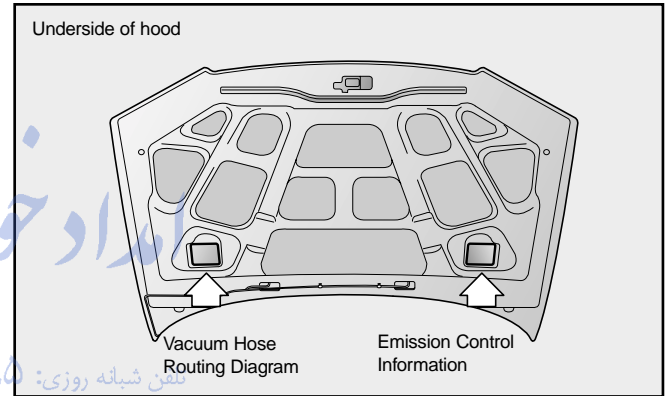

MMSA5002

FarmaSOS.com

# Driving Tips

## Tire Information Label

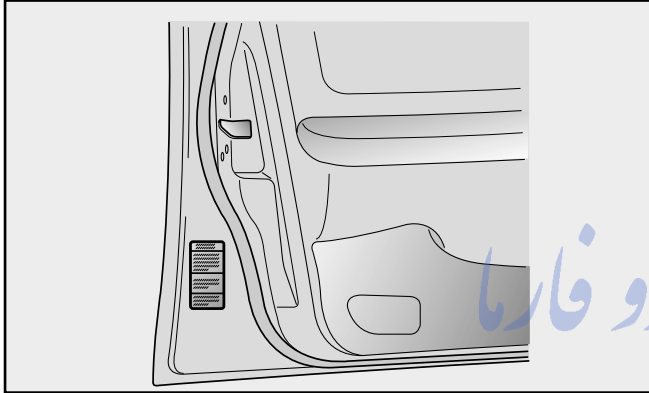

MMSA7019

## HOMELINK® WIRELESS CONTROL SYSTEM (IF EQUIPPED)

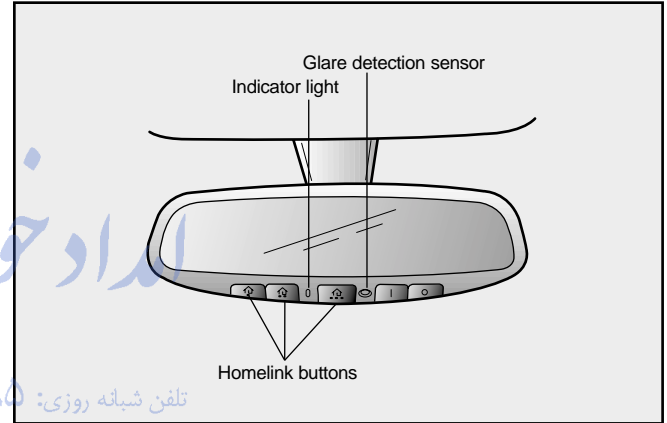

MMSA5007

Your new mirror comes with an integrated HomeLink Universal Transceiver, which allows you to program the mirror to activate your garage door(s), estate gate, home lighting, etc. The mirror actually learns the codes from your various existing transmitters.

## Homelink Programming

### CAUTION

- *Make sure people and/or objects are out of the way of any garage doors or gates you may be operating during the programming procedures.*
- *Keep original transmitters for potential future programming needs, or in case you sell the vehicle.*
- *In the event you do sell your vehicle, it's recommended you erase your programmed HomeLink mirror buttons.*

### WARNING

**Do not use HomeLink with any garage door opener that lacks the safety stop and reverse feature as required by federal safety standards (includes garage doors manufactured before April 1, 1982), as these doors can increase the risk of serious injury or death. Call 1.800.355.3515 or visit [www.homelink.com](http://www.homelink.com) for more information.**

## Programming

Your vehicles may require the ignition switch to be turned to the "ACC" position for programming and/or operation of HomeLink. It is also recommended that a new battery be replaced in the hand-held transmitter of the device being programmed to HomeLink for quicker training and accurate transmission of the radio-frequency.

Follow these steps to train your HomeLink mirror:

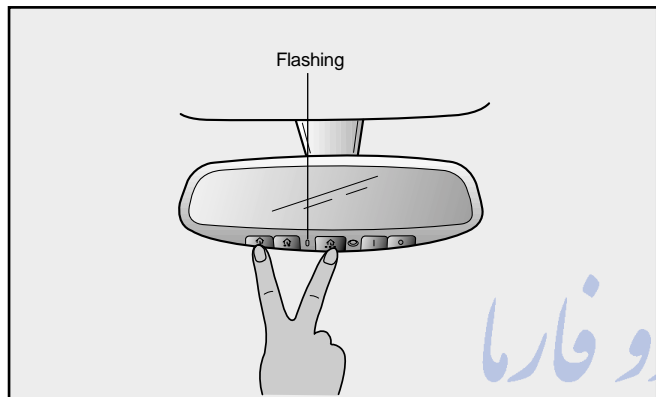

# Driving Tips

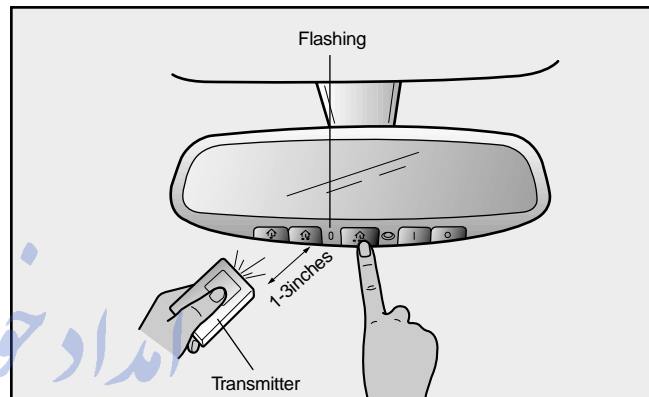

MMSA5005



MMSA5006

1. When programming the buttons for the first time, press and hold the two outside HomeLink buttons (  ,  ), releasing when the indicator light begins to flash (approximately 20 seconds). This procedure erases the factory-set default codes. Do not perform this step when programming additional transmitters.
2. Hold the transmitter of the device you want to train 1 to 3 inches away from the bottom of the mirror. Simultaneously press the hand-held transmitter button and the HomeLink button you wish to train. The indicator light will flash slowly at first, then rapidly, indicating successful programming.
3. If the garage door opener or other device you wish to train is rolling-code equipped, proceed to the "Rolling Code Programming" section below.
4. Repeat step 2 to program the remaining HomeLink buttons.

---

## Additional Programming for Rolling Code Devices

For any rolling-code-equipped device; follow the steps below after completing the "Programming" section. A second person may make the following steps easier.

1. Locate the "learn" or "smart" button on the device's motor head unit. The exact location and color of the button varies by product brand, but is usually referenced in the device's owner's manual. Contact HomeLink at 1.800.355.3515 or [www.homelink.com](http://www.homelink.com) for help.
2. Press and release the "learn" or "smart" button on the device's motor head unit.

### **\* NOTICE**

You now have 30 seconds to initiate step 3.

3. Return to the vehicle and firmly press and release the programmed HomeLink button. Press and release the same HomeLink button a second time to complete the training process. (Some devices may require you to press and release a third time to complete the training.)
4. Now your HomeLink mirror and the rolling-code-equipped device should be synchronized. The remaining HomeLink buttons may now be programmed if this has not been done previously.

## Operating HomeLink

Simply press the appropriate HomeLink button to activate the trained product (garage door, security system, entry door lock, estate gate, lighting, etc.). The original handheld transmitters may also be used at any time.

# Driving Tips

## Erasing Programmed Buttons

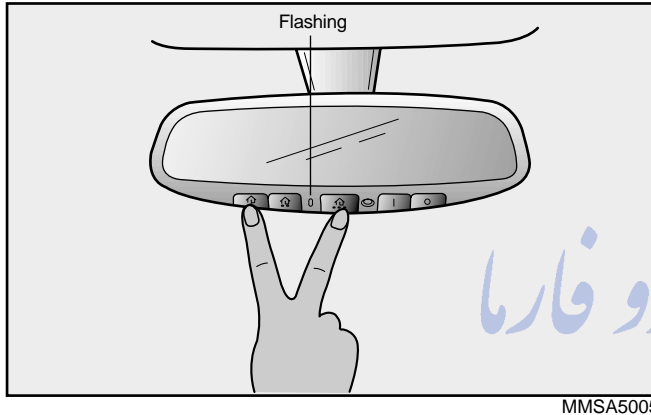

To erase the three HomeLink buttons, press and hold the two outside buttons until the indicator light begins to flash (after 20 seconds). Release both buttons.

Individual buttons cannot be erased, but can be reprogrammed.

## Reprogramming a Single HomeLink Button

To program a device to HomeLink using a HomeLink button previously trained, follow these steps:

1. Press and hold the desired HomeLink button. Do not release until step 4 has been completed.
2. When the indicator light begins to flash slowly (after 20 seconds), hold the handheld transmitter 1 to 3 inches away from the bottom of the mirror.
3. Press and hold the transmitter button (or, if necessary, press and "cycle," as described in the "Gate Operator & Canadian Programming" portion of this text).
4. The HomeLink indicator light will flash slowly at first, then rapidly, indicating successful programming. Release both buttons.

---

## Gate Operator Programming & Canadian Programming

During programming, your hand-held transmitter may automatically stop transmitting.

Continue to press and hold the HomeLink button while you press and repress ("cycle") your handheld transmitter every two seconds until the frequency signal has been learned. The indicator light will flash slowly at first and then rapidly upon successful training.

### \* NOTICE

If programming a garage door opener or gate, it is advised to unplug the device during the "cycling" process to prevent possible motor burnout.

## Accessories

For more information on HomeLink and HomeLink-compatible products, or to purchase HomeLink accessories, call 1.800.355.3515 or visit [www.homelink.com](http://www.homelink.com).

امداد خود و فارما

تلفن شبانه روزی: ۰۸۵ ۳۵۵۳۵۱۵

FarmaSOS.com

---

## IN CASE OF AN EMERGENCY

Road Warning .....	6-2
Overheating .....	6-2
Emergency Starting .....	6-4
Electrical Circuit Protection .....	6-7
Towing .....	6-14
If You Have a Flat Tire .....	6-19

تلفن شبانه روزی: ۰۲۱-۸۸۸۶۲۰۸۵

FarmaSOS.com

# In Case Of An Emergency

---

## ROAD WARNING

### *Hazard Warning Flasher*

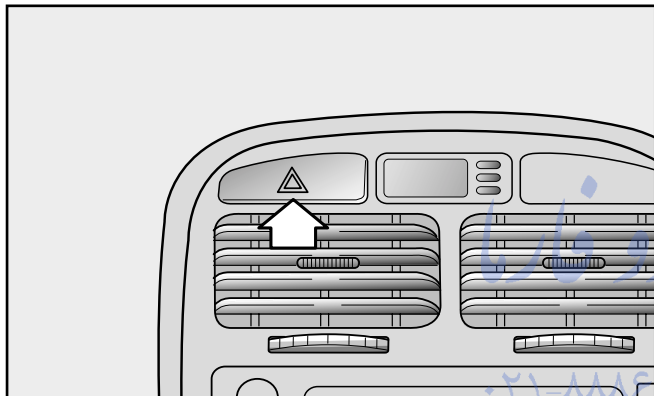

The hazard warning flasher serves as a warning to other drivers to exercise extreme caution when approaching, overtaking, or passing your vehicle. It should be used whenever emergency repairs are being made, when the vehicle is stopped near the edge of a roadway, or whenever your vehicle is in distress.

Depress the flasher switch to activate at any time. The flasher switch is located in the center console switch panel. All turn signal lights will flash simultaneously.

- The hazard warning flasher operates whether your vehicle is running or not.
- The turn signals do not work when the hazard flasher is on.
- Care must be taken when the hazard warning flasher is used while the vehicle is being towed. Local regulations may prohibit using it in this manner.

## OVERHEATING

If your temperature gauge indicates overheating, if you experience a loss of power, or if you hear a loud knocking or pinging noise, the engine has probably overheated. Should any of these symptoms occur, use the following procedure:

- 
1. Turn on the hazard warning flasher, then drive to the nearest safe location and stop your vehicle; shift to Neutral (manual transaxle) or Park (automatic transaxle) and apply the parking brake.
  2. Make sure the air conditioner is off.
  3. If coolant or steam is boiling out of the radiator, stop the engine and call an authorized Kia dealer or other competent repair shop for assistance.

If there is no visible coolant, you may allow the engine to idle and open the hood to permit the engine to cool gradually.

If the temperature does not go down with the engine idling, stop the engine and allow sufficient time for it to cool.

4. The coolant level should then be checked. Use the coolant reservoir dipstick to check the level. If the level in the reservoir is low, look for leaks at the radiator hoses and connections, heater hoses and connections, radiator, and water pump. If you find a major leak or another problem that may have caused the engine to overheat, do not operate the engine until it has been corrected. Call an authorized Kia dealer or other competent repair shop for assistance. If you do not find a leak or other problem, carefully add coolant to the reservoir.

**⚠ WARNING - Removing Radiator Cap**

**Never remove the radiator cap when the engine and radiator are hot. Scalding hot coolant and steam may blow out under pressure. This could cause serious injury.**

*If the engine frequently overheats, have the cooling system checked and repaired.*

# In Case Of An Emergency

## EMERGENCY STARTING

### *Jump Starting*

Jump starting can be dangerous if done incorrectly. Therefore, to avoid harm to yourself or damage to your vehicle or battery, follow the jump starting procedures on this page. If in doubt, we strongly recommend that you have a competent technician or towing service jump start your vehicle.

#### **\* NOTICE**

Use only a 12-volt jumper system. You can damage a 12-volt starting motor, ignition system, and other electrical parts beyond repair by use of a 24-volt power supply (either two 12-volt batteries in series or a 24-volt motor generator set).

#### **⚠ WARNING - Battery**

Never attempt to check the electrolyte level of the battery as this may cause the battery to rupture or explode causing serious injury.

#### **⚠ WARNING - Battery**

- Keep all flames or sparks away from the battery. The battery produces hydrogen gas which may explode if exposed to flame or sparks.
- Do not attempt to jump start the vehicle if the discharged battery is frozen or if the electrolyte level is low; the battery may rupture or explode.

### *Jump Starting Procedure*

1. Make sure the booster battery is 12-volt and that its negative terminal is grounded.
2. If the booster battery is in another vehicle, do not allow the vehicles to touch.
3. Turn off all unnecessary electrical loads.

## Connecting Jumper Cables

Connect cables in numerical order and disconnect in reverse order

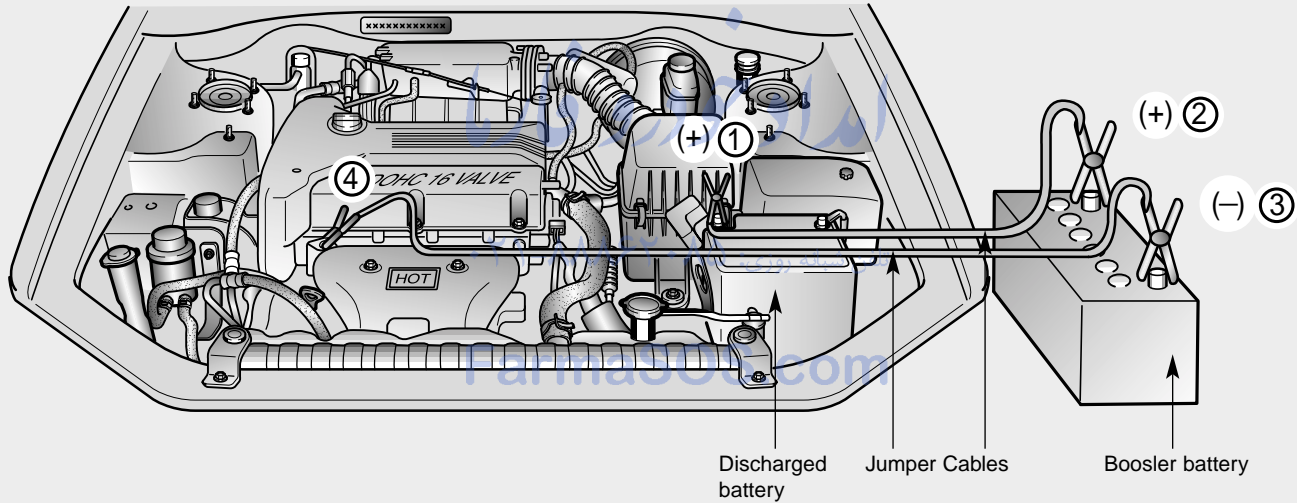

MMSA6002



## ELECTRICAL CIRCUIT PROTECTION

### Fuses

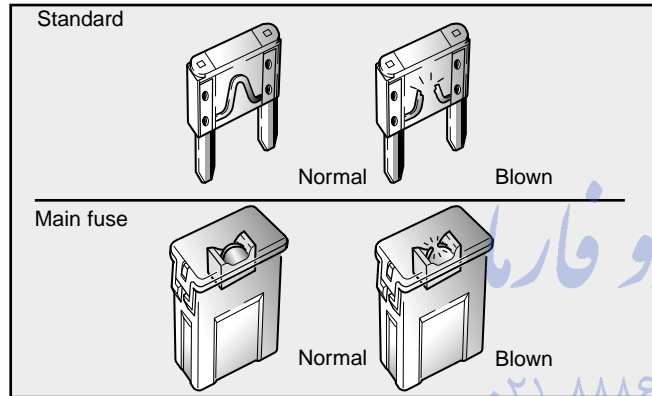

A vehicle's electrical system is protected from electrical overload damage by fuses.

This vehicle has two fuse panels, one located in the driver's side kick panel, the other in the engine compartment near the battery.

If any of your vehicle's lights, accessories, or controls do not work, check the appropriate circuit fuse. If a fuse has blown, the element inside the fuse will be melted.

Always replace a blown fuse with one of the same rating.

If the same fuse blows again, avoid using the system involved and immediately consult an authorized Kia dealer.

*Two kinds of fuses are used: standard for lower amperage rating and main for higher amperage ratings.*

# In Case Of An Emergency

## Fuse Replacement

### **⚠ WARNING - Fuse Replacement**

- Never replace a fuse with anything but another fuse of the same rating.
- A higher capacity fuse could cause damage and possibly a fire.
- Never install a wire instead of the proper fuse – even as a temporary repair. It may cause extensive wiring damage and possibly a fire.
- Do not use a screwdriver or any other metal object to remove fuses because it may cause a short circuit and damage the system.

If the electrical system does not work, first check the driver's side fuse panel.

1. Turn the ignition switch and all other switches off.

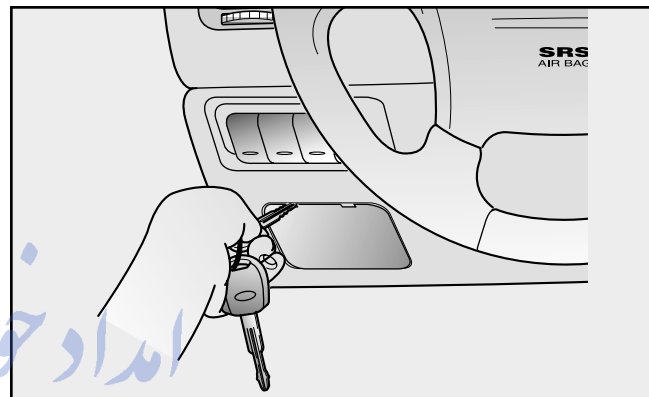

MMSA6020

2. Using a key, remove the fuse box cover.
3. Pull the suspected fuse straight out. Use the removal tool provided on the cover (if equipped). Refer to the fuse panel chart on the fuse panel cover to identify the likely problem fuse or electrical circuit.
4. Check the removed fuse; replace it if it is blown. The number of fuses vary according to the vehicle model. Check both the passenger and engine compartment fuse box covers.
5. Push in a new fuse of the same rating, and make sure it fits tightly in the clips.

If it fits loosely, consult an authorized Kia dealer.

If you do not have a spare, use a fuse of the same rating from a circuit you may not need for operating the vehicle, such as the radio or clock (Room) fuse.

If the headlights or other electrical components do not work and the fuses are OK, check the fuse block in the engine compartment. If a fuse is blown, it must be replaced.

1. Turn the ignition switch and all other switches off.
2. Remove the fuse block cover by unhooking the tab on one end and tilting the cover back toward the other end.
3. Check the fuses. If one is blown, replace it with a new one of the same rating.

### \* NOTICE

After checking the fuse box in the engine compartment, please securely install the fuse box cover. If not, electrical failures may occur from water leaking in.

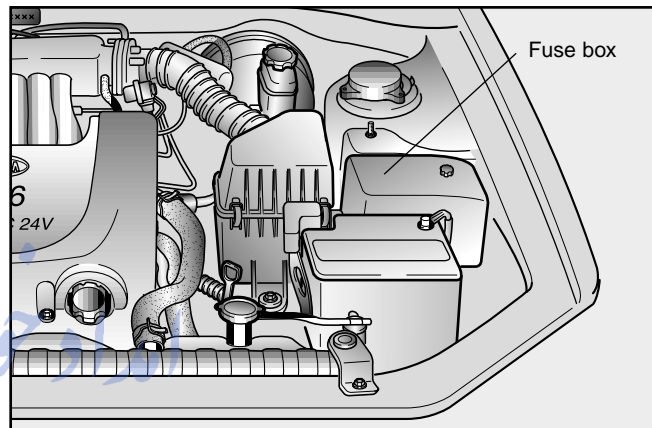

MMSA6005

تلفن شبانه روزی: ۰۸۵ ۸۸۶۲۰۸۵  
FarmaSOS.com

# In Case Of An Emergency

## Fuse Panel Description (Engine compartment)

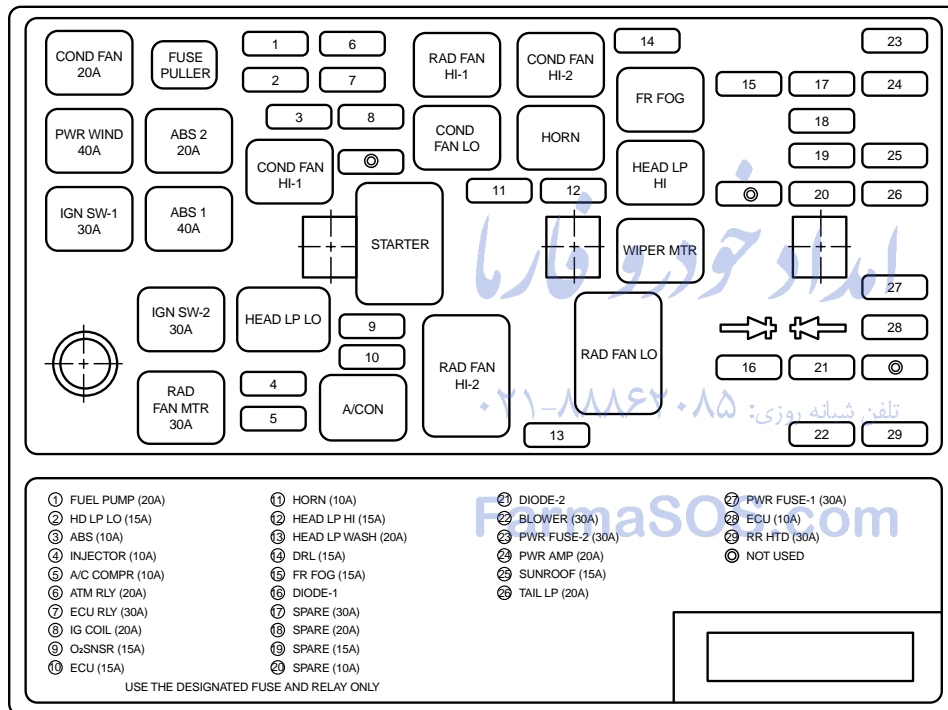

2MS106001A

DESCRIPTION	FUSE RATING	PROTECTED COMPARTMENTS
COND FAN	20A	Condenser fan
PWR WIND	40A	Power window
ABS 2	20A	ABS
IGN SW-1	30A	Ignition switch
ABS 1	40A	ABS
IGN SW-2	30A	Ignition switch
RAD FAN MTR	30A	Radiator fan motor
FUEL PUMP	20A	Fuel pump
HD LP LO	15A	Headlights (LO)
ABS	10A	ABS
INJECTOR	10A	Injector
A/C COMPR	10A	Air-con compressor
ATM RLY	20A	ATM Relay
ECU RLY	30A	Engine control unit relay
IG COIL	20A	Ignition coil
O <sub>2</sub> SNSR	15A	Oxygen sensor
ECU	15A	Engine control unit

DESCRIPTION	FUSE RATING	PROTECTED COMPARTMENTS
HORN	10A	Horn
HEAD LP HI	15A	Headlights (HI)
HEAD LP WASH	20A	-
DRL	15A	DRL
FR FOG	15A	Front fog lights
DIODE-1	-	Diode 1
SPARE	30A	Spare fuse
SPARE	20A	Spare fuse
SPARE	15A	Spare fuse
SPARE	10A	Spare fuse
DIODE-2	-	Diode 2
BLOWER	30A	Blower
PWR FUSE-2	30A	Power fuse 2
PWR AMP	20A	Power amp
SUNROOF	15A	Sunroof
TAIL LP	20A	Tail lights
PWR FUSE-1	30A	Power fuse 1
ECU	10A	ECU
RR HTD	30A	Rear window defroster

# In Case Of An Emergency

## Passenger Compartment Fuse Panel Description (Driver's side kick panel)

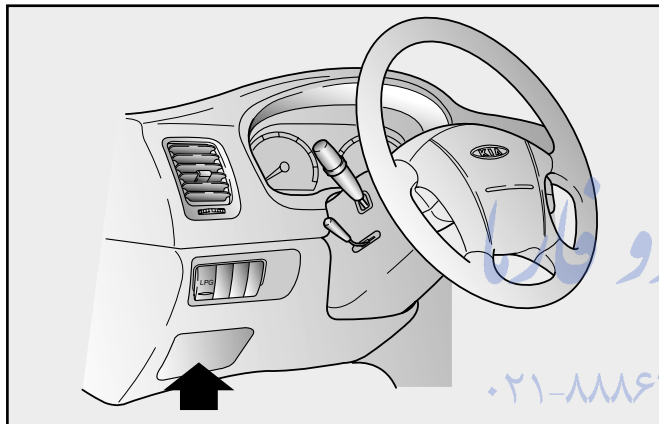

MMSA6006

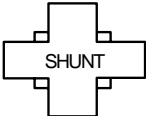
10A RR HTD IND	10A HAZARD	15A RR FOG	10A A/CON	10A ETACS	15A DR LOCK
25A P/SEAT (DRIVE)	15A T/LID OPEN	15A STOP LP	10A H/LP	10A A/BAG IND	10A T/SIG
10A A/CON SW	15A ACC SOCKET	15A S/HTR	15A A/BAG	10A B/UP	10A CLUSTER
10A START	15A SP 1	15A FRT HTD	25A P/SEAT (PASS)	15A SP 4	10A D/CLOCK
10A TAIL (LH)	10A AUDIO	20A WIPER	 SHUNT		10A ROOM LP
10A TAIL (RH)	15A C/LIGHTER	10A EPS			
USE THE DESIGNATED FUSE ONLY.					

2MS106002A

DESCRIPTION	FUSE RATING	PROTECTED COMPARTMENTS
RR HTD IND	10A	Rear window defroster, Outside rear view mirror heater
HAZARD	10A	Hazard light, Turn signal lights
RR FOG	15A	Rear fog light
A/CON	10A	Air conditioning system
ETACS	10A	ETACS, Keyless entry system, Door lock system
DR LOCK	15A	Power door lock
P/SEAT (DRIVE)	25A	Power seat
T/LID OPEN	15A	Remote trunk lid
STOP LP	15A	Stop lights
H/LP	10A	Head light
A/BAG IND	10A	Air-bag
T/SIG	10A	Turn signal lights
A/CON SW	10A	Air conditioning system
ACC SOCKET	15A	Power outlet
S/HTR	15A	Seat heater
A/BAG	15A	Air-bag
B/UP	10A	Backup lights

DESCRIPTION	FUSE RATING	PROTECTED COMPARTMENTS
CLUSTER	10A	Cluster
START	10A	Engine switch
SP1	15A	Spare fuse
FRT HTD	15A	Window defroster
P/SEAT (PASS)	25A	Power seat
SP4	15A	Spare fuse
D/CLOCK	10A	Digital clock
TAIL(LH)	10A	Position lights, License plate lights, Tail lights
AUDIO	10A	Audio
WIPER	20A	Wiper
ROOM LP	10A	Dome lights, Front door edge warning lights
TAIL(RH)	10A	Position lights, License plate lights, Tail lights
C/LIGHTER	15A	Cigar lighter
EPS	10A	-

# In Case Of An Emergency

## TOWING

If emergency towing is necessary, we recommend having it done by an authorized Kia dealer or a commercial tow-truck service. Proper lifting and towing procedures are necessary to prevent damage to the vehicle. State and local laws applicable to towing vehicles must be followed. As a general rule, towed vehicles should be pulled with the driving wheels off the ground. If excessive damage or other conditions prevent towing the vehicle with the driving wheels of the ground, use wheel dollies.

When being towed by a commercial tow truck and wheel dollies are not used, the front of the vehicle should be lifted, not the rear.

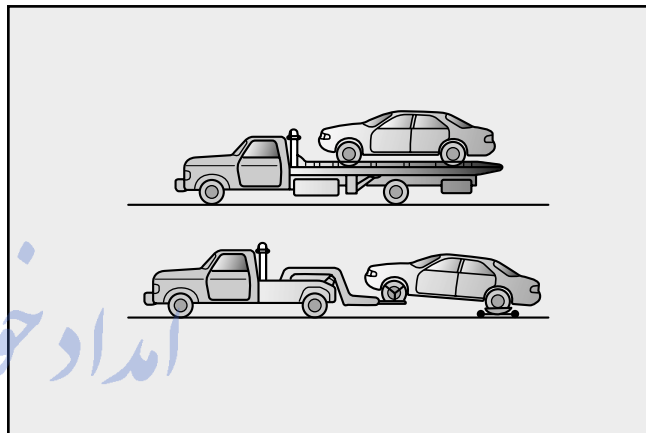

MMSA6007A

### \* NOTICE

Do not tow the vehicle backwards with the front wheel on the ground as this may cause damage to the transaxle.

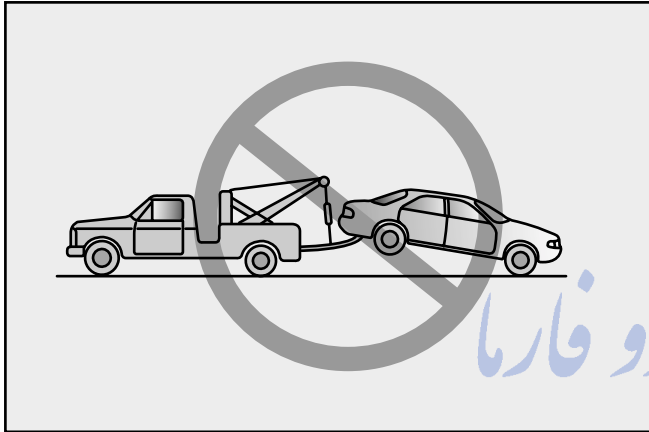

MMSA6008

When towing your vehicle in an emergency without wheel dollies:

1. Set the ignition switch in the ACC position;
2. Place the transaxle shift lever in N (Neutral);
3. Release the parking brake.

### \* NOTICE

Failure to place the transaxle shift lever in neutral may cause internal damage to the transaxle.

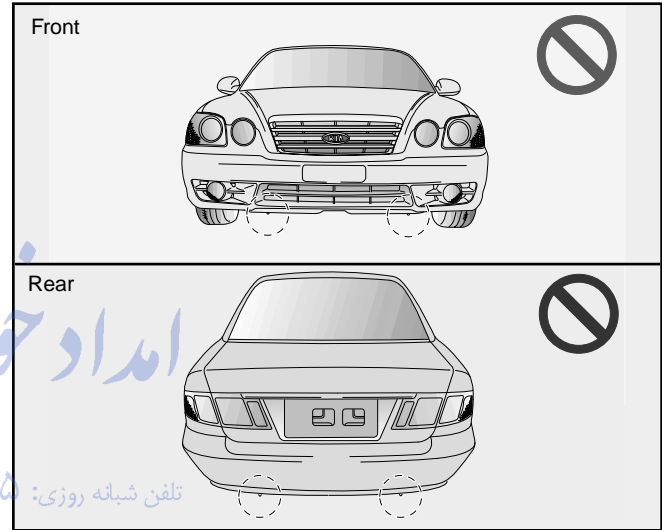

MMSA6009B/MMSA601A

### Tie-down hooks (for flatbed towing)

#### **CAUTION**

*Do not use the tie-down hooks for towing purposes. The hooks are designed ONLY for transport tie-down. If the tie-down hooks are used for towing, the tie-down hooks will be damaged and this could lead to serious injury.*

# In Case Of An Emergency

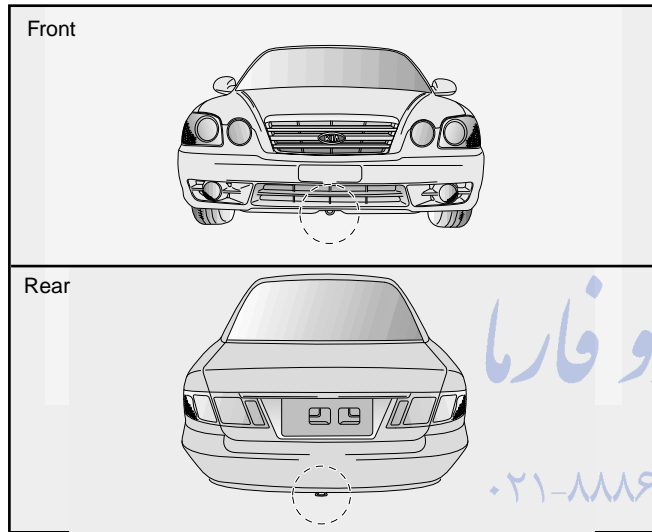

MMSA6009A/MMSA6010

## ***Towing with a vehicle other than a tow truck***

If towing is necessary, we recommend you to have it done by an Authorized Kia dealer or a commercial tow truck service.

If towing service is not available in an emergency, your vehicle may be temporarily towed using a cable or chain secured to the emergency towing hook. Use extreme caution when towing the vehicle.

A driver must be in the vehicle to steer it and operate the brakes.

Towing in this manner may be done only on hard-surfaced roads for a short distance and at low speeds. Also, the wheels, axles, power train, steering and brakes must all be in good condition.

- Do not try to tow your vehicle when the wheels are stuck in mud, sand or similar substances that prevent the vehicle from being driven out under its own power.
- Avoid towing a vehicle heavier than the vehicle doing the towing.
- The drivers of both vehicles should communicate with each other frequently.

## **\* NOTICE**

- Attach a towing strap to the tow hook.
- Using a portion of the vehicle other than the tow hooks for towing may damage the body of your vehicle.
- Use only a cable or chain specifically intended for use in towing vehicles. Securely fasten the cable or chain to the towing hook provided.

## **CAUTION**

*Use extreme caution when towing the vehicle.*

- *Avoid sudden starts or erratic driving maneuvers which would place excessive stress on the emergency towing hook and towing cable or chain. The hook and towing cable or chain may break and cause serious injury or damage.*
- *If the towing vehicle can hardly move, do not forcibly continue the towing. Contact an Authorized Kia dealer or a commercial tow truck service for assistance.*
- *Tow the vehicle as straight ahead as possible.*
- *Keep away from the vehicle during towing.*

- Before emergency towing, check that the hook is not broken or damaged.
- Fasten the towing cable or chain securely to the hook.
- Do not jerk the hook. Apply steady and even force.
- To avoid damaging the hook, do not pull from the side or at a vertical angle. Always pull straight ahead.

- Use a towing strap less than 16 feet (5 m) long. Attach a white or red cloth (about 12 inches (30 cm) wide) in the middle of the strap for easy visibility.
- Drive carefully so that the towing strap is not loosened during towing.

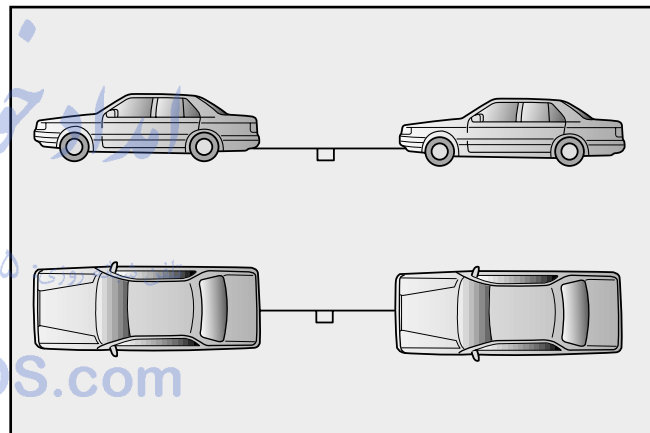

MMSA6011

# In Case Of An Emergency

---

## ***When Your Vehicle Is Being Towed By Another Vehicle Other Than a Tow Truck (in case of an emergency)***

- Turn the ignition switch to ACC so the steering wheel isn't locked.
- Place the transaxle shift lever in N (Neutral).
- Vehicles equipped with automatic transaxles should not exceed 28 mph and should not be towed more than 50 miles.
- Vehicles equipped with manual transaxles should not be towed in excess of 55 mph and should not be towed more than 400 miles.
- Press the brake pedal with more force than normal since you will have reduced brake performance.
- More steering effort will be required because the power steering system will be disabled.
- If you are driving down a long hill, the brakes may overheat and brake performance will be reduced. Stop often and let the brakes cool off.

## **\* NOTICE**

*To prevent internal damage to the transaxle, never tow your vehicle from the rear (backwards) with all four tires in contact with the road surface wheel dollies must be used.*

## ***Tips for towing a stuck vehicle***

The following methods are effective when your vehicle is stuck in mud, sand or similar substances that prevent the vehicle from being driven out under its own power.

- Remove the soil and sand, etc. from the front and the back of the tires.
- Place a stone or wood under the tires.

## IF YOU HAVE A FLAT TIRE

The spare tire, tool bag, jack and jack handle are stored in the trunk compartment. Move the carpeting out of the way to reach this equipment.

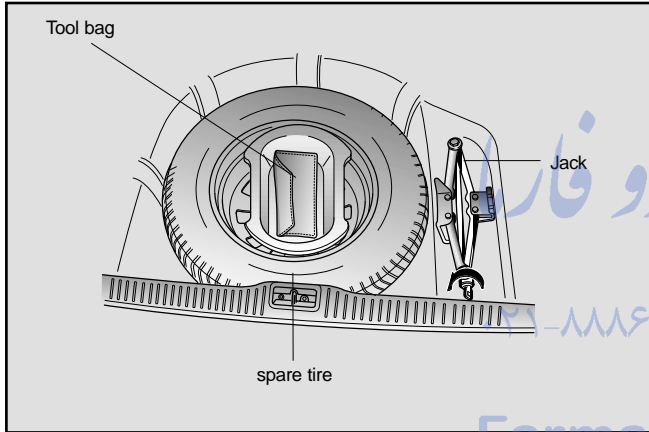

MMSA6012

*To remove the jack:*

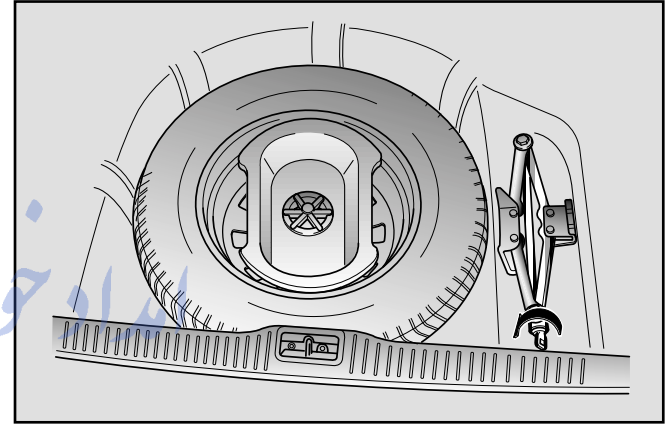

MMSA6013

Turn the jack socket counterclockwise.

FarmSOS.com

# In Case Of An Emergency

## Removing the Spare Tire:

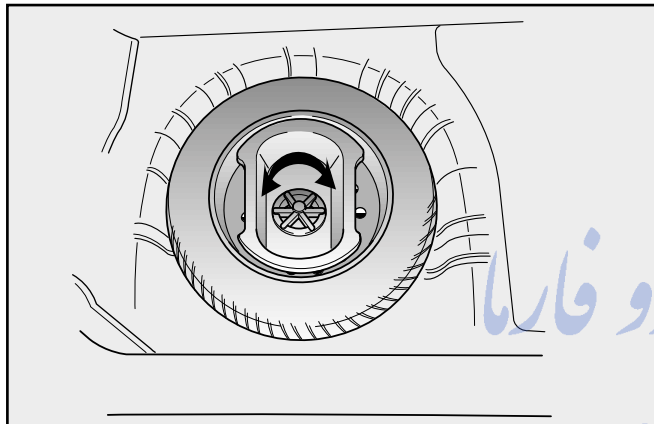

MMSA6014A

Turn the tire hold-down wing bolt counterclockwise. Store the tire in the reverse order of removal.

To prevent the jack, jack handle, and tool bag from “rattling” while the vehicle is in motion, store them properly.

## Important — Use of Compact Spare Tire

Your vehicle is equipped with a compact spare tire. This compact spare tire takes up less space than a regular-size tire. This tire is smaller than a conventional tire and is designed for temporary use only.

### **CAUTION**

- You should drive carefully when the compact spare is in use. The compact spare should be replaced by the proper conventional tire and rim at the first opportunity.
- The operation of this vehicle is not recommended with more than one compact spare tire in use at the same time.

### **CAUTION**

This spare tire should be used only for **VERY** short distances. Compact spares should **NEVER** be used for long drives or extended distances.

---

The compact spare (if equipped) should be inflated to 60 psi (415 kPa).

**\* NOTICE**

Check the inflation pressure after installing the spare tire. Adjust it to the specified pressure, as necessary.

When using a compact spare tire, observe the following precautions:

- Under no circumstances should you exceed 80 km/h (50 mph); a higher speed could damage the tire.
- Ensure that you drive slowly enough for the road conditions to avoid all hazards. Any road hazard, such as a pothole or debris, could seriously damage the compact spare.
- Any continuous road use of this tire could result in tire failure, loss of vehicle control, and possible personal injury.
- Do not exceed the vehicle's maximum load rating or the load-carrying capacity shown on the sidewall of the compact spare tire.
- Avoid driving over obstacles. The compact spare tire diameter is smaller than the diameter of a conventional tire and reduces the ground clearance approximately 25 mm (1 in.), which could result in damage to the vehicle.
- Do not take this vehicle through an automatic car wash.
- Do not use tire chains on this tire. Because of the smaller size, a tire chain will not fit properly. This could damage the vehicle and result in loss of the chain.
- This tire should not be installed on the front axle if the vehicle must be driven in snow or on ice.
- Do not use the compact spare tire on any other vehicle because this tire has been designed especially for your vehicle.
- The compact spare's tread life is shorter than a regular tire. Inspect your compact spare tire regularly and replace worn compact spare tires with the same size and design, mounted on the same wheel.

# In Case Of An Emergency

---

## ***Changing Tires***

### ***Jacking Instructions***

The jack is provided for emergency tire changing only.

Follow jacking instructions to reduce the possibility of personal injury.

#### **⚠ WARNING - Changing Tires**

- Never attempt vehicle repairs in the traffic lanes of a public road or highway.
- Always move the vehicle completely off the road and onto the shoulder before trying to change a tire. If you cannot find a firm, level place off the road, call a towing service company for assistance.

*(Continued)*

*(Continued)*

- Be sure to use the correct front and rear jacking positions on the vehicle; never use the bumpers or any other part of the vehicle for jack support.
- The vehicle can easily roll off the jack causing serious injury or death. Never allow any portion of your body to get beneath the vehicle while using the jack.
- Do not start or run the engine while the vehicle is on the jack.  
Do not allow anyone to remain in the vehicle while it is on the jack.  
Make sure any children present are in a secure place away from the road and from the vehicle to be raised with the jack.

## ***Tire Replacement***

1. Park on a level surface and set the parking brake firmly.
2. For manual transaxle vehicles, shift into R (Reverse). For automatic transaxle vehicles, shift into P (Park).
3. Activate the hazard warning flasher.

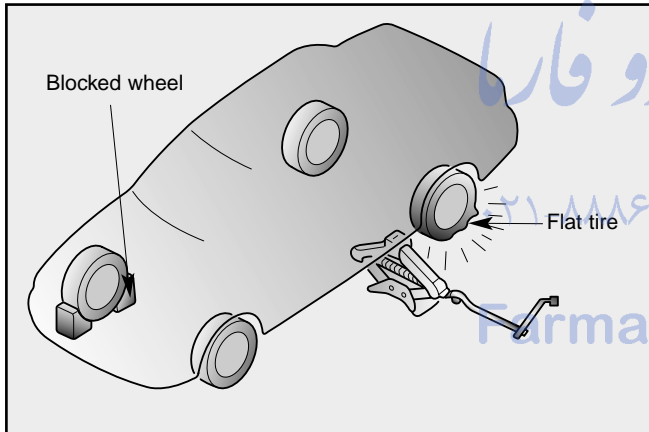

MMSA6015

4. Remove the wheel lug nut wrench, jack, jack handle, and spare tire from the vehicle.
5. Block both the front and rear of the wheel that is diagonally opposite the jack position.
6. For models with alloy wheels, remove the center cap.

### **⚠ WARNING - Changing a Tire**

To prevent vehicle movements while changing a tire, always set the parking brake fully, and always block the wheel diagonally opposite the wheel being changed.

# In Case Of An Emergency

- Loosen the wheel nuts counterclockwise one turn each, but do not remove any nut until the tire has been raised off the ground.

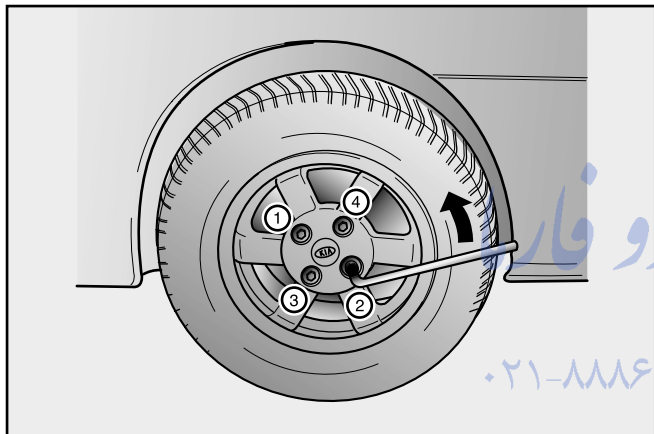

MMSA6016

- Place the jack at the front or rear jacking position closest to the tire you are changing. Place the jack at the designated locations under the frame. The jacking positions are plates welded to the frame with two tabs and a raised dot to index with the jack.

## **⚠ WARNING - Jack Location**

To reduce the possibility of injury, be sure to use only the jack provided with the vehicle and in the correct jack position; never use any other part of the vehicle for jack support.

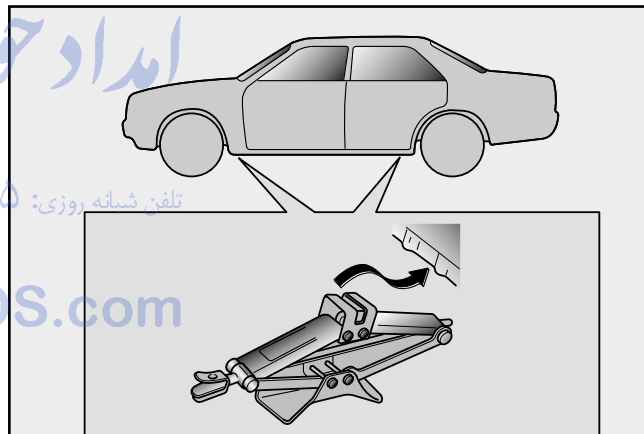

MMSA6017

9. Insert the jack handle into the jack and turn it clockwise, raising the vehicle until the tire just clears the ground. This measurement is approximately 1.2 in (30mm). Before removing the wheel lug nuts, make sure the vehicle is stable and that there is no chance for movement or slippage.
10. Remove the wheel lug nuts by turning them counterclockwise, then remove the wheel.
11. Mount the spare tire into position and tighten the wheel nuts by hand. Install the wheel lug nuts with the beveled edge inward.

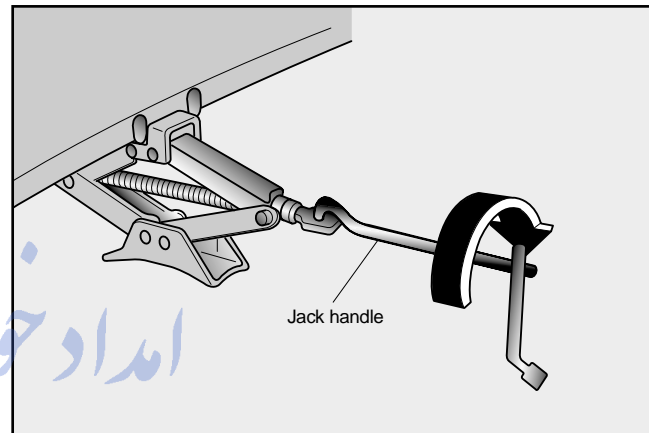

MMSA6018

تلفن شبانه روزی: ۰۲۱-۸۸۸۶۲۰۸۵

FarmaSOS.com

# In Case Of An Emergency

12. Turn the jack handle counterclockwise and lower the vehicle until it touches the ground. Tighten the wheel lug nuts firmly in a “X” pattern as indicated in the diagram.

Once the lug nuts have been tightened, lower the vehicle fully to the ground and continue to tighten the lug nuts until they are fully secured.

If you are unsure of the tightness of the wheel lug nuts, have them checked at the nearest service station. The specified tightening torque is 76 ft. lb. (103 N•m).

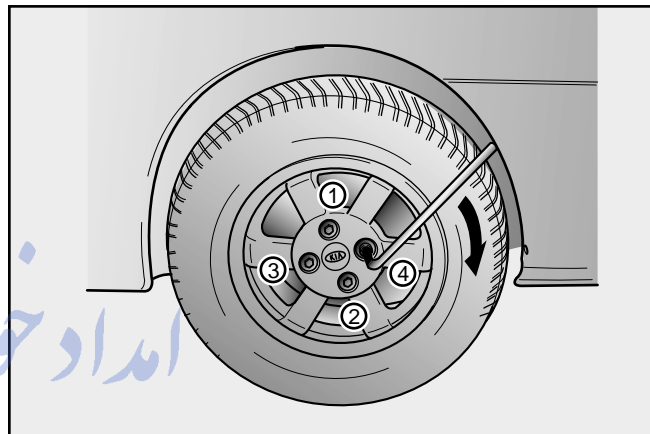

MMSA6019

تلفن شبانه روزی: ۰۲۱-۸۸۸۶۲۰۸۵

FarmaSOS.com

## \* NOTICE

Your vehicle has metric threads on the wheel studs and nuts. When changing a wheel, make sure that the same nuts removed are reinstalled – or, if replaced, that nuts with metric threads of the same chamfer configuration are used. Installation of a non-metric thread nut on a metric stud or vice-versa will not secure the wheel to the hub properly and will damage the stud requiring replacement.. Note that most U.S. lug nuts do not have metric threads. Be sure to use extreme care in checking for thread style before installing aftermarket lug nuts or wheels. If in doubt, consult an Authorized Kia Dealer.

## WARNING - Wheel Studs

**If the studs are damaged, they may lose their ability to retain the wheel. This can lead to the loss of the wheel, loss of control and a collision.**

*To prevent the jack, jack handle, wheel lug nut, wrench and spare tire from rattling while the vehicle is in motion, store them properly.*

---

## MAINTENANCE

Maintenance Services .....	7-3
Schedule 1 - Normal Maintenance .....	7-5
Schedule 1 - Severe Maintenance .....	7-8
Owner Maintenance .....	7-11
Engine Compartment .....	7-15
Engine Oil and Oil Filter .....	7-17
Engine Cooling System .....	7-21
Brakes and Clutch .....	7-26
Parking Brake .....	7-27
Power Steering .....	7-27
Manual Transaxle .....	7-28
Automatic Transaxle .....	7-30
Lubricants and Fluids .....	7-33
Air Cleaner .....	7-35
Wiper Blades .....	7-37
Battery .....	7-40

# Maintenance

---

Tires and Wheels .....	7-44
Bulb Replacement .....	7-53
Lubricant Specifications .....	7-60
Exterior Care .....	7-63
Interior Care .....	7-66
Headlight Aiming Adjustment .....	7-68

امداد خودرو فارما  
تلفن شبانه روزی: ۰۲۱-۸۸۸۶۲۰۸۵

[FarmaSOS.com](http://FarmaSOS.com)

---

## MAINTENANCE SERVICES

You should exercise the utmost care to prevent both damage to your vehicle and injury to yourself whenever performing any maintenance or inspection procedures.

Should you have any doubts concerning the inspection or servicing of your vehicle, we strongly recommend that you have a reliable and qualified service shop perform this work, preferably an authorized Kia dealer.

An authorized Kia dealer has factory-trained technicians and genuine Kia parts to service your vehicle properly. For expert advice and quality service, see an authorized Kia dealer.

Inadequate, incomplete or insufficient servicing may result in operational problems with your vehicle that could lead to vehicle damage, an accident, or personal injury.

## *Owner's Responsibility*

### **\* NOTICE**

Maintenance, Service and Record Retention are the owner's responsibility.

You should retain documents to show proper maintenance has been performed on your vehicle in accordance with the scheduled maintenance service charts shown on the following pages. You need this information to establish your compliance with the servicing and maintenance requirements of your Kia warranties.

Detailed warranty information is provided in your Warranty and Consumer Information Manual.

Repairs and adjustments required as a result of improper maintenance or a lack of required maintenance are not covered.

# Maintenance

---

We recommend you have your vehicle maintained and repaired by an Authorized Kia Dealer. An Authorized Kia Dealer meets Kia's high service quality standards and receives technical support from Kia in order to provide you with a high level of service satisfaction.

## ***Scheduled Maintenance Service***

If none of the following conditions are applicable, then use Schedule 1 – Normal Maintenance.

- Repeated short distance driving.
- Driving in dusty conditions or sandy areas.
- Extensive use of brakes.
- Driving in areas where salt or other corrosive materials are being used.
- Driving on rough or muddy roads.
- Driving in mountainous areas.
- Extended periods of idling or low speed operation.
- Driving for a prolonged period in cold temperatures and/or extremely humid climates.
- More than 50% driving in heavy city traffic during hot weather above 90°F (32°C)

However, if any of the preceding conditions apply, follow Schedule 2 – Severe Maintenance.

*After 105 months or 105,000 miles (168,000 km) continue to follow the prescribed maintenance intervals.*

# SCHEDULE 1 - NORMAL MAINTENANCE

MAINTENANCE INTERVALS  MAINTENANCE ITEM	Number of Months or Miles (kilometers), whichever comes first														
	Months	7.5	15	22.5	30	37.5	45	52.5	60	67.5	75	82.5	90	97.5	105
	Miles x 1,000	7.5	15	22.5	30	37.5	45	52.5	60	67.5	75	82.5	90	97.5	105
	(km x 1,000)	(12)	(24)	(36)	(48)	(60)	(72)	(84)	(96)	(108)	(120)	(132)	(144)	(156)	(168)
Drive belts				I					I				I		
Engine oil	R	R	R	R	R	R	R	R	R	R	R	R	R	R	R
Engine oil filter	R	R	R	R	R	R	R	R	R	R	R	R	R	R	R
Manual transaxle oil	I	I	I	I	I	I	I	I	I	I	I	I	I	I	I
Automatic transaxle fluid	I	I	I	I	I	I	I	I	I	I	I	I	I	I	R
Engine timing belt				I					R(1)				I		
Air cleaner element					R				R				R		
Spark plugs									R						

I: Inspect and, if necessary, adjust, correct, clean or replace.

R: Replace or change.

(1) For California, this maintenance is recommended, but not required.

FarmaSOS.com

# Maintenance

## SCHEDULE 1 - NORMAL MAINTENANCE (CONTINUED)

MAINTENANCE INTERVALS  MAINTENANCE ITEM	Number of Months or Miles (kilometers), whichever comes first														
	Months	7.5	15	22.5	30	37.5	45	52.5	60	67.5	75	82.5	90	97.5	105
	Miles x 1,000 (km x 1,000)	7.5 (12)	15 (24)	22.5 (36)	30 (48)	37.5 (60)	45 (72)	52.5 (84)	60 (96)	67.5 (108)	75 (120)	82.5 (132)	90 (144)	97.5 (156)	105 (168)
Cooling system					I				I					I	
Engine coolant (3)	Replace every 24 months or 30,000 miles														
Idle speed					I (2)				I (1)					I (2)	
Fuel filter									R (1)						
Fuel tank, cap, lines and hoses					I (2)				I (1)					I (2)	
Fuel hoses (California)	Inspect every 105,000 miles (168,000 km)														
Hose and tube for emission	Outside California								I (2)						
	California								I (2)						
	Replace every 105,000 miles (168,000 km)														
Fuel tank air filter					I				R					I	

I: Inspect and, if necessary, adjust, correct, clean or replace.

R: Replace or change.

- (1) This maintenance is required in all states except California. However, we recommend that it also be performed on California vehicles.
- (2) This maintenance is recommended by Kia. However, it is not necessary for emission warranty coverage or manufacturer recall liability.
- (3) Coolant level adjustment and leak : Inspect regularly.

## SCHEDULE 1 - NORMAL MAINTENANCE (CONTINUED)

MAINTENANCE INTERVALS  MAINTENANCE ITEM	Number of Months or Miles (kilometers), whichever comes first															
	Months	7.5	15	22.5	30	37.5	45	52.5	60	67.5	75	82.5	90	97.5	105	
	Miles x 1,000 (km x 1,000)	7.5 (12)	15 (24)	22.5 (36)	30 (48)	37.5 (60)	45 (72)	52.5 (84)	60 (96)	67.5 (108)	75 (120)	82.5 (132)	90 (144)	97.5 (156)	105 (168)	
Brake lines and connections				I					I				I			
Drum brakes				I					I				I			
Disc brakes				I					I				I			
Brake fluid/Clutch fluid (if equipped) (1)		I		I		I		I		I		I		I		
Steering operation and linkage				I					I				I			
Front suspension ball joints				I					I				I			
Driveshaft dust boots				I					I				I			
Chassis/body nuts and bolts				I					I				I			
Exhaust system heat shield				I					I				I			
All locks and hinges	L	L	L	L	L	L	L	L	L	L	L	L	L	L	L	
Air conditioner refrigerant (if equipped)	<b>Inspect refrigerant amount annually</b>															
Air conditioner compressor (if equipped)	<b>Inspect operation annually</b>															
Air filter (if equipped)	<b>Replace every 9,500 miles (15,000 km)</b>															

I: Inspect and, if necessary, adjust, correct, clean or replace. (1) If there has been continuous of hard driving, mountain driving, or if the brakes are used extensively or the vehicle is operated in extremely humid climates, the brake fluid should be changed annually.  
 L: Lubricate.

# Maintenance

## SCHEDULE 1 - SEVERE MAINTENANCE

MAINTENANCE INTERVALS  MAINTENANCE ITEM	Number of Months or Miles (kilometers), whichever comes first																				
	Months	5	10	15	20	25	30	35	40	45	50	55	60	65	70	75	80	85	90	95	100
	Miles x 1,000	5	10	15	20	25	30	35	40	45	50	55	60	65	70	75	80	85	90	95	100
	(km x 1,000)	(8)	(16)	(24)	(32)	(40)	(48)	(56)	(64)	(72)	(80)	(88)	(96)	(104)	(112)	(120)	(128)	(136)	(144)	(152)	(160)
Drive belts						I						I						I			
Engine oil	R	R	R	R	R	R	R	R	R	R	R	R	R	R	R	R	R	R	R	R	R
Engine oil filter	R	R	R	R	R	R	R	R	R	R	R	R	R	R	R	R	R	R	R	R	R
Manual transaxle oil	I	I	I	I	I	I	I	I	I	I	I	R	I	I	I	I	I	I	I	I	I
Automatic transaxle fluid	I	I	I	I	I	R	I	I	I	I	I	R	I	I	I	I	I	R	I	I	I
Engine timing belt				I				R(1)				I					R(1)				I
Air cleaner element			I (2&3)			R				I (2&3)			R			I (2&3)			R		
Spark plugs						R							R						R		
Cooling system						I							I						I		
Engine coolant (4)	Replace every 24 months or 30,000 miles.																				

I: Inspect and, if necessary, adjust, correct, clean or replace.

R: Replace or change.

(1) For California, this maintenance is recommended, but not required.

(2) This maintenance is recommended by Kia. However, it is not necessary for emission warranty coverage or manufacturer recall liability.

(3) Inspect, and if necessary, replace.

(4) Coolant level adjustment and leak : Inspect regularly.

## SCHEDULE 2 - SEVERE MAINTENANCE

MAINTENANCE INTERVALS  MAINTENANCE ITEM	Number of Months or Miles (kilometers), whichever comes first																				
	Months	5	10	15	20	25	30	35	40	45	50	55	60	65	70	75	80	85	90	95	100
	Miles x 1,000	5	10	15	20	25	30	35	40	45	50	55	60	65	70	75	80	85	90	95	100
	(km x 1,000)	(8)	(16)	(24)	(32)	(40)	(48)	(56)	(64)	(72)	(80)	(88)	(96)	(104)	(112)	(120)	(128)	(136)	(144)	(152)	(160)
Idle speed						I(2)							I(1)							I(2)	
Fuel filter													R(1)								
Fuel tank, cap, lines and hoses						I(2)							I							I(2)	
Fuel hoses (California)	Inspect every 105,000 miles (168,000 km)																				
Hose and tube for emission	Outside California												I(2)								
	California												I(2)								
		Replace every 105,000 miles (168,000 km)																			
Fuel tank air filter			I				R			I			R			I				R	

I: Inspect and, if necessary, adjust, correct, clean or replace.

R: Replace or change.

(1) This maintenance is required in all states except California. However, we recommend that it also be performed on California vehicles.

(2) This maintenance is recommended by Kia. However, it is not necessary for emission warranty coverage or manufacturer recall liability.

(3) Inspect, and if necessary, replace.

# Maintenance

## SCHEDULE 2 - SEVERE MAINTENANCE (CONTINUED)

MAINTENANCE INTERVALS  MAINTENANCE ITEM	Number of Months or Miles (kilometers), whichever comes first																				
	Months	5	10	15	20	25	30	35	40	45	50	55	60	65	70	75	80	85	90	95	100
	Miles x 1,000	5	10	15	20	25	30	35	40	45	50	55	60	65	70	75	80	85	90	95	100
	(km x 1,000)	(8)	(16)	(24)	(32)	(40)	(48)	(56)	(64)	(72)	(80)	(88)	(96)	(104)	(112)	(120)	(128)	(136)	(144)	(152)	(160)
Brake lines and connections							I						I						I		
Drum brakes							I						I						I		
Disc brakes			I				I		I				I		I				I		
Steering operation and linkage							I						I						I		
Front suspension ball joints							I						I						I		
Driveshaft dust boots							I						I						I		
Chassis/body nuts and bolts			I				I		I				I		I				I		
Exhaust system heat shield							I						I						I		
All locks and hinges	L	L	L	L	L	L	L	L	L	L	L	L	L	L	L	L	L	L	L	L	L
Air conditioner refrigerant (if equipped)	Inspect refrigerant amount annually																				
Air conditioner compressor (if equipped)	Inspect operation annually																				

I: Inspect and, if necessary, adjust, correct, clean or replace.

L: Lubricate.

---

## OWNER MAINTENANCE

### *Owner Maintenance Schedule*

The owner or a qualified service technician should perform these vehicle inspections at the indicated intervals to ensure safe and dependable operation.

Bring any problem to the attention of an authorized Kia dealer or qualified service technician as soon as possible.

When refueling, check the following:

- Engine oil level
- Engine coolant level

### **⚠ WARNING**

**Be careful when checking your engine coolant level. The engine compartment will be hot and you could be burned.**

- Brake (and clutch, if equipped) fluid level
- Washer fluid level

تلفن شبانه روزی: ۰۲۱-۸۸۸۶۲۰۸۵

FarmaSOS.com

# Maintenance

---

## Every month, check:

- Tire inflation pressures (cold)
- Coolant level in reservoir (cold engine)

## Every 6 months (for example, every spring and fall), check:

- Power steering fluid level
- Automatic transaxle fluid level

You can do the following scheduled maintenance items if you have some mechanical ability, a few basic tools, and if you closely follow the directions in this manual.

When servicing your vehicle use only genuine Kia replacement parts or equivalent. Genuine Kia parts can be obtained from your authorized Kia dealer.

When removing parts with gaskets or seals, replace the gasket or seal with a new part before reassembly. Be sure to completely remove the old gasket and any remaining sealant, without marring the mating surfaces, before installing the new part.

فارما سوس  
تلفن شیبک زوری: ۰۲۱-۸۸۸۶۲۰۸۵

FarmaSOS.com

## **Owner Maintenance Precautions**

Improper or incomplete service may result in problems. This section gives instructions only for items that are easy to perform.

### **WARNING - Maintenance Work**

**You can be seriously injured while performing some maintenance procedures. If maintenance is performed improperly, a vehicle system could fail in use causing injury to you or others. If there is any possibility you lack sufficient knowledge and experience or the proper tools and equipment to do the work, have it done by a qualified technician.**

### **\* NOTICE**

Improper maintenance by owner during the warranty period may affect warranty coverage. For details, read the separate Kia Warranty and Consumer Information Manual provided with the vehicle. If you're unsure about any servicing or maintenance procedure, have it performed by an authorized Kia dealer.

# Maintenance

---

## **⚠ WARNING - Loose Clothing or Jewelry**

Working under the hood with the engine running is dangerous. It becomes even more dangerous when you wear jewelry or loose clothing. Either can become entangled in moving parts and result in injury. Therefore, if you must run the engine while working under the hood, make certain that you remove all jewelry (especially rings, bracelets, watches, and necklaces) and all neckties, scarves, and similar loose clothing before getting near the engine or cooling fans.

## **⚠ WARNING - Engine Cooling Fans**

Because your engine cooling fans are electronically controlled, they will run if the ignition switch is ON, even if the engine is not running. This could cause serious injury. To prevent this, be sure the ignition is OFF, unless you must run the engine while performing maintenance or an inspection.

تلفن شبانه روزی: ۰۸۵۰۶۲۰۸۵  
FarmaSOS.com

# ENGINE COMPARTMENT

2400cc 4-cyl. DOHC Engine

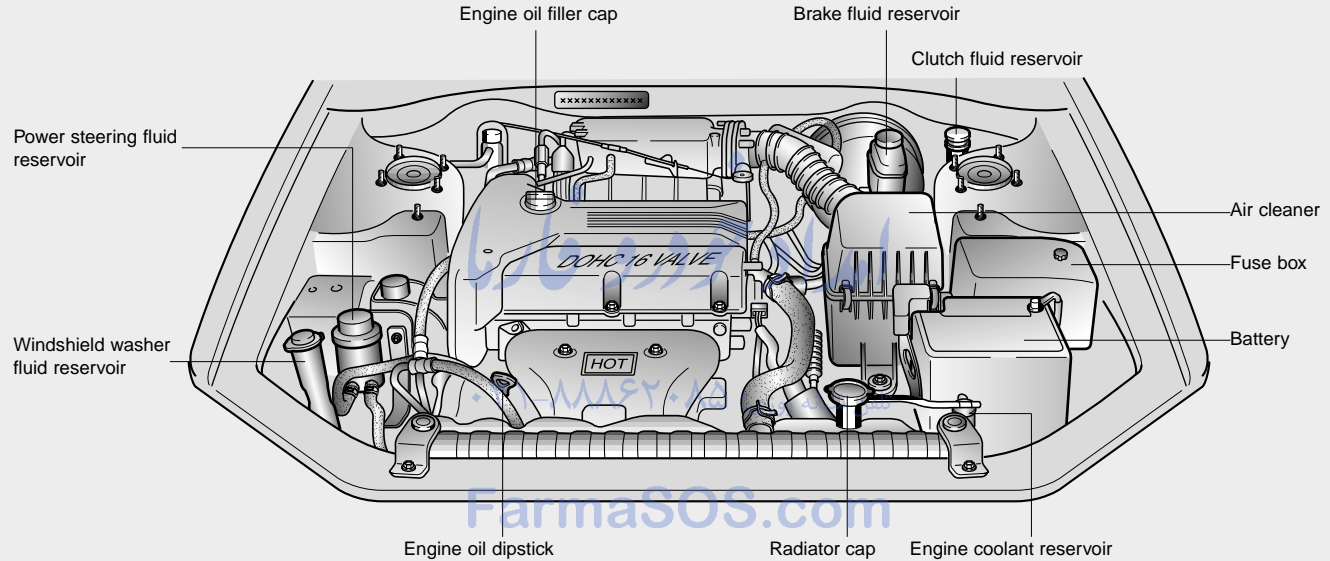

MMSA7001

# Maintenance

## 2700cc V-6 DOHC Engine

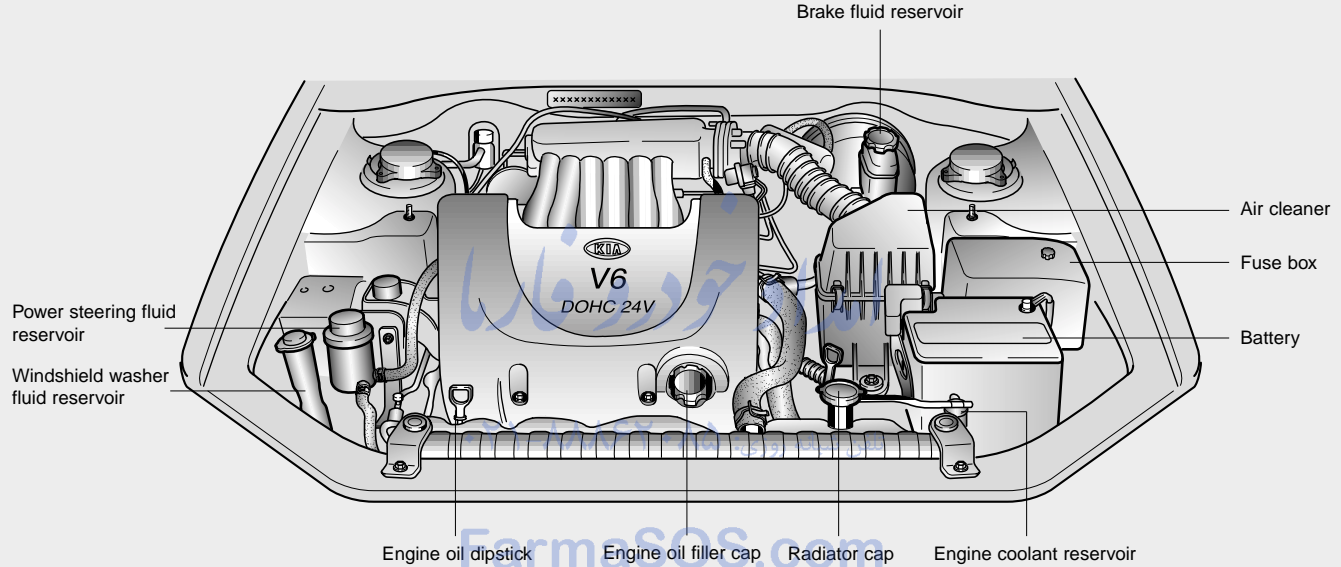

MMSA7002

## ENGINE OIL AND OIL FILTER

### *Checking the Engine Oil Level*

1. Be sure the vehicle is on level ground.
2. Start the engine and allow it to reach normal operating temperature.
3. Turn the engine off and wait a few minutes for the oil to return to the oil pan.
4. Pull the dipstick out, wipe it clean, and re-insert it fully.
5. Pull the dipstick out again and check the level. The level should be between F and L.

If the level is near or at L, add enough oil to bring the level to F. **Do not overfill.**

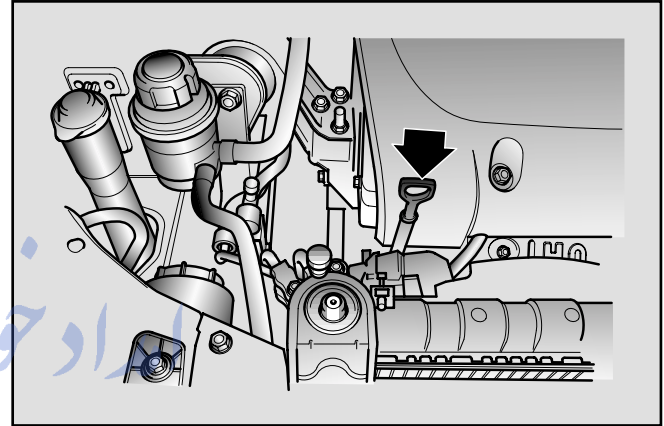

MMSA7003

*Use only the specified engine oil. (Refer to "Recommended Lubricants" later in this section.)*

FarmaSOS.com

# Maintenance

---

## ***Changing the Engine Oil and Filter***

Change engine oil and filter according to the Scheduled Maintenance at the beginning of this section.

1. Run the engine for a few minutes to warm it up, then turn it off. Remove the oil filler cap.
2. Remove the drain plug from the oil pan and drain the engine oil into a suitable container.

### **⚠ WARNING - Engine Oil**

Continuous contact with USED engine oil has caused skin cancer in laboratory mice. Protect your skin by washing with soap and water. Keep all engine oil out of reach of children.

### **⚠ WARNING - Burns**

Both the oil and engine are hot. Avoid contact to avoid burning yourself.

تلفن شبانه روزی: ۰۲۱-۸۸۸۶۲۰۸۵

FarmaSOS.com

---

3. Remove the engine oil filter with an oil filter wrench.

**\* NOTICE**

Do not allow the oil filter gasket to remain on the oil filter mounting surface. This will cause oil leakage and engine damage. Remove the old gasket completely so that a new gasket may be properly seated.

4. Use a clean rag to clean the oil filter mounting surface on the engine.

5. Apply a small amount of engine oil to the new oil filter O-ring seal.

6. Install the oil filter and tighten it. (Refer to the oil filter caution label for tightening instructions.)

7. Install a new washer on the drain plug.

8. Replace the drain plug after the oil has thoroughly drained. Torque the plug to 12.3~18 lb.-ft. (16.7~24.5 N•m).

9. Refill the engine with new oil to the F mark on the dipstick. Do not overfill.

10. Replace the oil filler cap securely.

11. Start the engine and inspect around the oil filter seal for leaks. Stop the engine.

12. Check the oil level and fill to the F mark as necessary.

امداد خودرو فارما

تلفن شبانه روزی: ۰۲۱-۸۸۸۶۲۰۸۵

FarmaSOS.com

# Maintenance

---

## Oil Capacity

- 2400cc 4-cyl. Engine
  - Without filter change : 4.2 qts (4.0 liters)
  - With filter change : 4.5 qts (4.3 liters)
- 2700cc V-6 Engine
  - Without filter change : 4.75 qts (4.5 liters)
  - With filter change : 5.1 qts (4.8 liters)

*Use only the specified service grade engine oil.*

## \* NOTICE

- Although oil filters may have the same external appearance, their internal designs differ significantly. These filters are not interchangeable. To avoid potential engine damage, use only the specified filter. Consult an authorized Kia dealer.
- Follow these instructions carefully. An improper oil filter installation can cause oil leakage and engine damage. Drained engine oil should be disposed of properly, according to local environmental protection agency codes. It should not be thrown down the drain or in the trash.

FarmaSOS.com

---

## ENGINE COOLING SYSTEM

The high-pressure cooling system has a reservoir filled with year-round antifreeze coolant. The reservoir is filled at the factory.

Check the antifreeze protection and coolant level at least once a year, at the beginning of the winter season, and before traveling to a colder climate.

### *Checking the Coolant Level*

#### **⚠ WARNING - Removing Radiator Cap**

- **Never attempt to remove the radiator cap while the engine is operating. Doing so might lead to cooling system and engine damage and could result in serious personal injury from escaping hot coolant or steam. Turn the engine off and wait until it has cooled. Even then, use extreme care when removing the radiator cap. Wrap a thick towel around it, and turn it counterclockwise slowly to the first stop. Step back while the pressure is released from the cooling system. When you are sure all the pressure has been released, press down on the cap, using a thick towel, and continue turning counterclockwise to remove it.**

*(Continued)*

# Maintenance

**(Continued)**

- Even if the engine is not operating, do not remove the radiator cap or the drain plug while the engine and radiator are hot. Hot coolant and steam may still blow out under pressure, causing serious injury.

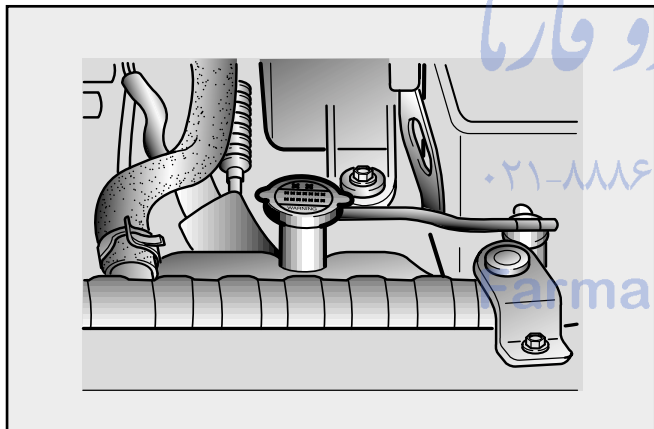

MMSA7004

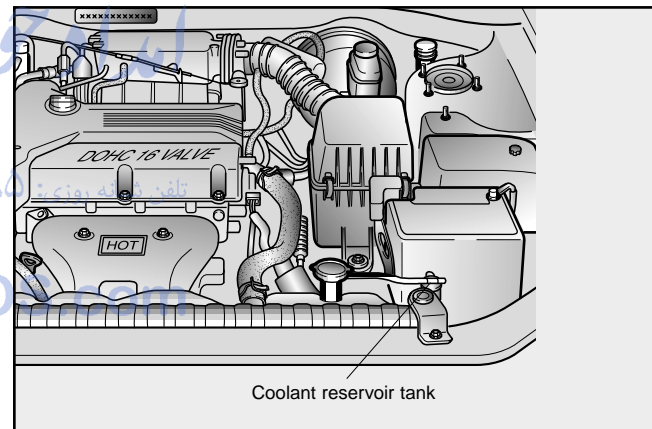

MMSA7005

Check the condition and connections of all cooling system hoses and heater hoses. Replace any swollen or deteriorated hoses.

The coolant level should be full in the radiator and between F (Full) and L (Low) on the coolant reservoir tank when the engine is cool.

Check the coolant level using the dipstick attached to the reservoir cap.

---

If the coolant level is low, add enough coolant to bring the level to F, but do not overfill. If frequent additions are required, see an authorized Kia dealer or another competent repair center for a cooling system inspection.

### **Changing Coolant**

Change coolant according to the Scheduled Maintenance.

- *Use only soft (de-mineralized) water in the coolant mixture.*
- *The engine in your vehicle has aluminum engine parts and must be protected by an ethylene-glycol-based coolant to prevent corrosion and freezing.*
- *DO NOT USE alcohol or methanol antifreeze or mix them with the specified coolant.*
- *Do not use a solution that contains more than 60% antifreeze or less than 35% antifreeze, which would reduce the effectiveness of the solution.*

فارسوس فارما  
۰۲۱-۸۸۸۶۲۰۸۵  
FarmaSOS.com

# Maintenance

For mixture percentage, refer to the following table.

Ambient Temperature	Mixture percentage (volume)	
	Coolant solution	Water
5°F (-15°C)	35	65
-13°F (-25°C)	40	60
-31°F (-35°C)	50	50
-49°F (-45°C)	60	40

## **CAUTION**

*To prevent burning yourself, do not remove the radiator cap or loosen the drain plug while the engine is hot.*

## **Procedure for changing coolant:**

1. Turn the radiator cap counterclockwise to remove it.
2. Loosen the radiator drain plug and drain the coolant into a suitable container.
3. With the plug loose, flush the system with running water.
4. Drain the system completely and retighten the drain plug. Add the necessary amount of ethylene-glycol-based coolant and water to provide the required protection against freezing and corrosion. In extremely cold climates, add ethylene-glycol based coolant in accordance with the instructions of the manufacturer.

FarmaSOS.com

- 
5. Run the engine at idle with the radiator cap off. Slowly add additional coolant as necessary.
  6. At this point, wait until the engine reaches normal operating temperature. Depress the accelerator two or three times; then add coolant as required. **Be careful not to burn yourself.**
  7. Replace the radiator cap. Inspect all connections for leaks and recheck the coolant level in the reservoir. Recheck again after a few days and add coolant as necessary.

امداد خودرو فارما  
تلفن شبانه روزی: ۰۲۱-۸۸۸۶۲۰۸۵

FarmaSOS.com

# Maintenance

## BRAKES AND CLUTCH

### Checking Brake/Clutch Fluid Level

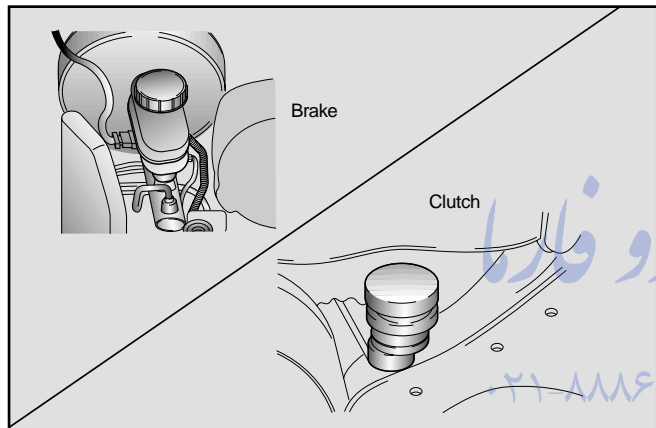

Check the fluid level in the reservoir periodically. The fluid level should be between MAX and MIN indicators on the side of the reservoir.

Before removing the reservoir cap and adding brake fluid, clean the area around the reservoir cap thoroughly to prevent brake/clutch fluid contamination.

If the level is low, add fluid to the MAX level. The level will fall with accumulated mileage. This is a normal condition associated with the wear of the brake/clutch linings. If the fluid level becomes low frequently, have the brake/clutch system checked by an authorized Kia dealer or another competent repair center.

*Use only the specified brake/clutch fluid. (Refer to "Recommended Lubricants" later in this section.)*

*Never mix different types of fluid.*

### \* NOTICE

In the event the brake/clutch system requires frequent additions of fluid, the vehicle should be inspected by an authorized Kia dealer or another competent repair center.

## PARKING BRAKE

### Checking the Parking Brake

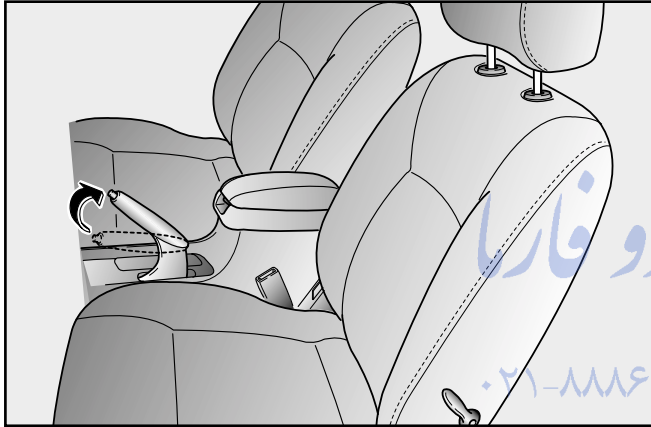

Check the stroke of the parking brake by counting the number of “clicks” heard while fully applying it from the released position. Also, the parking brake alone should securely hold the vehicle on a fairly steep grade. If the number of “clicks” is more or less than specified, have the parking brake adjusted by an authorized Kia dealer or another competent repair center.

#### **Stroke:**

5~9 “clicks” at a force of 44 lbs (196N).

## POWER STEERING (IF EQUIPPED)

### Checking the Power Steering Fluid Level

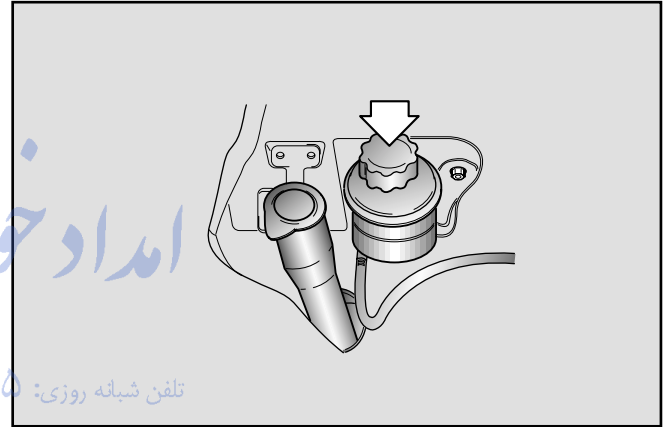

With the vehicle on level ground, check the fluid level in the power steering reservoir periodically. The fluid level should be between MAX and MIN indicators on the side of the reservoir.

If the level is low, add fluid to the MAX level.

# Maintenance

---

In the event the power steering system requires frequent addition of fluid, the vehicle should be inspected by an authorized Kia dealer or another competent repair center.

*Use only the specified power steering fluid. (Refer to “Recommended Lubricants” later in this section.)*

## \* NOTICE

To avoid damage to the power steering pump, do not operate the vehicle for prolonged periods with a low power steering fluid level.

## MANUAL TRANSAXLE (IF EQUIPPED)

### *Checking the Manual Transaxle Oil Level*

1. Raise and suitably support the vehicle.

### **⚠ WARNING - Lifting Your Vehicle**

If you raise your vehicle, always ensure that it is supported at all four jacking or lift points for the vehicle. Do not use jacks meant for tire changes. Use only lift equipment specifically recommended for doing maintenance work under the vehicle. Place the vehicle and lift equipment on a hard, level surface capable of supporting the full weight of the vehicle without moving or deforming. If the support is not stable, the vehicle could fall and cause serious or fatal injuries. Follow the instructions with the lift device.

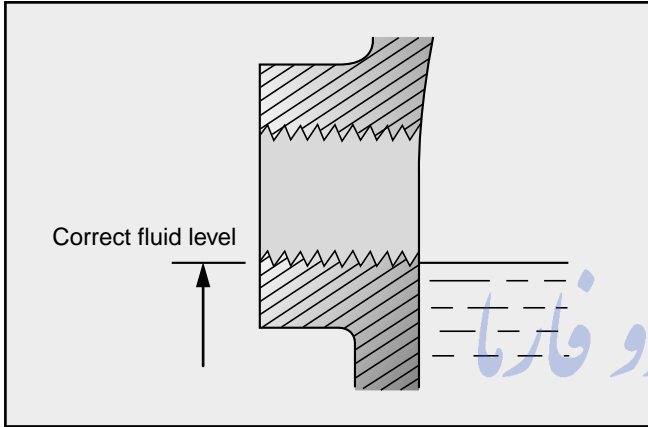

MMSA7009

2. Remove the fill/check plug on the side of the transaxle.
3. Verify that the oil level reaches the bottom of the fill/check hole. Fill as necessary.

*If the oil level is low, check for leaks before adding oil. Do not overfill. Use only the specified manual transaxle oil. (Refer to "Recommended Lubricants" later in this section.)*

4. Install a new washer on the fill/check plug and tighten the plug to 22 lb•ft. (30 N•m).

امداد خودرو فارما

تلفن شبانه روزی: ۰۸۵-۲۰۶۲۰۸۸۶-۰۲۱

ParmaSOS.com

# Maintenance

---

## ***Changing the Manual Transaxle Oil***

1. Raise and suitably support the vehicle.
2. Remove the drain plug on the bottom of the transaxle.
3. After the oil has drained completely, install a new washer on the plug, reinstall the drain plug and tighten to 22 lb•ft (30 N•m).
4. Remove the fill/check plug on the side of the transaxle.
5. Add oil through the fill/check hole until it reaches the bottom of the fill/check hole.
6. Install a new washer on the fill/check plug.
7. Reinstall and tighten the fill/check plug to 22 lb•ft (30 N•m).

*Use only the specified manual transaxle oil.  
(Refer to “Recommended Lubricants” later in this section.)*

## **AUTOMATIC TRANSAXLE**

### ***Checking the Automatic Transaxle Fluid Level***

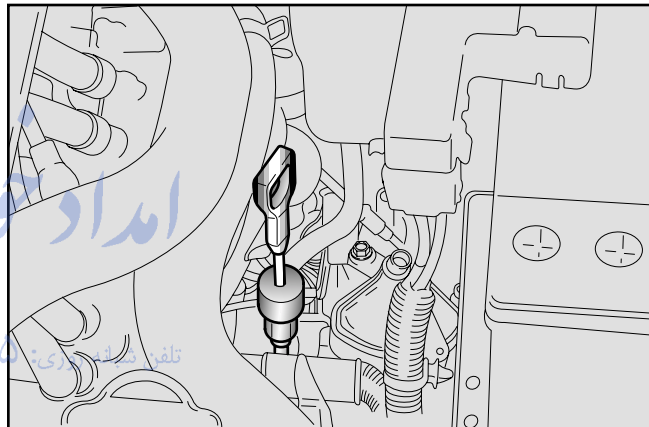

MMSA7010

The automatic transaxle fluid level should be checked regularly.

The volume of the transaxle fluid changes with temperature. Although it is best to check the level

after having driven the vehicle for at least 30 minutes, the level can be checked after warming the fluid using the procedure below.

### \* NOTICE

- Low transaxle fluid level causes transaxle/transaxle slippage. Overfilling can cause foaming, loss of fluid and transaxle malfunction.
- The use of a non-specified fluid could result in transaxle malfunction and failure.

### **⚠ WARNING - Parking Brake**

To avoid sudden movement of the vehicle, set the parking brake and depress the brake pedal before moving the shift lever.

1. Park the vehicle on level ground and firmly set the parking brake.

2. Allow the engine to idle for about 2 minutes.
3. Depress the brake pedal and move the shift lever slowly through all ranges then set it in N (Neutral).
4. With the engine still idling, pull out the dipstick, wipe it clean and reinsert it fully.

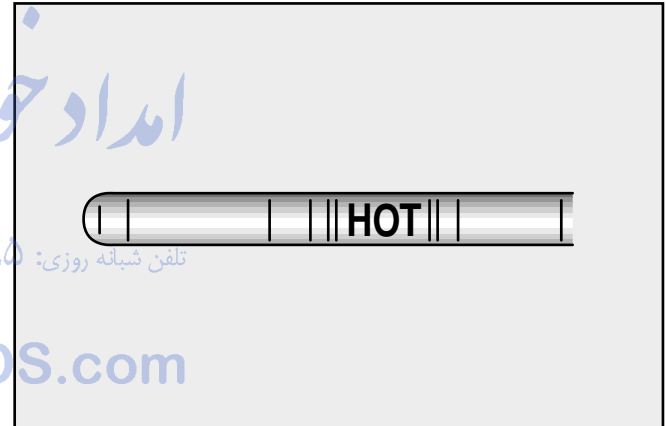

MMSA7011

5. Pull out the dipstick again and check the fluid level.

# Maintenance

---

## Using the hot fluid scale:

If the vehicle has been driven and the fluid is warmed to the normal operating temperature of approximately 158~176°F (70~80°C), the fluid level should be within “HOT” range.

- Use the cold scale as a rough reference only.
- If the outside temperature is lower than 68°F (20°C), start the engine and measure the fluid level after letting the engine reach operating temperature.
- If the vehicle has been driven for an extended period at high speeds or in city traffic in hot weather, it is usually best to measure the fluid level after stopping the engine and allowing the fluid to cool for 30 minutes.

When inserting the dipstick, be sure to insert it completely. When adding fluid, measure frequently with the dipstick to make sure the fluid level does not go above the Full position. Do not overfill.

Use only the specified automatic transaxle fluid. (Refer to “Recommended Lubricants” later in this section.)

## *Changing the Automatic Transaxle Fluid*

1. Raise and suitably support the vehicle.
2. Remove the drain plug located at the bottom center front of the transaxle pan.
3. After the oil has drained, completely install a new washer on the plug, reinstall the drain plug, and tighten to 22 lb•ft (30 N•m).
4. Lower the vehicle.
5. Remove the Automatic Transaxle dipstick located near the center of the engine compartment bulkhead and, using a funnel, add approximately 2 quarts (2 liters) of automatic transaxle fluid (SK ATF SP-III or diamond ATF SP-III or equivalent).

## \* NOTICE

Do NOT overfill the automatic transaxle reservoir. Doing so can cause a seal “blow out,” loss of fluid, and damage to the transaxle. If you overfill the reservoir, you must drain the excess prior to driving the vehicle. The transaxle will hold 2.7 qts. (2.5L) when completely empty. However, it is likely that there will be fluid left in the transaxle after draining, especially if the front of the vehicle was raised to remove the drain plug.

6. Check the fluid level. If necessary, add a small amount of fluid and check the level again. Continue this process until the level reads within “HOT” range.
7. Replace the dipstick and properly dispose of the used transaxle fluid.

## LUBRICANTS AND FLUIDS

### *Checking the Washer Fluid Level*

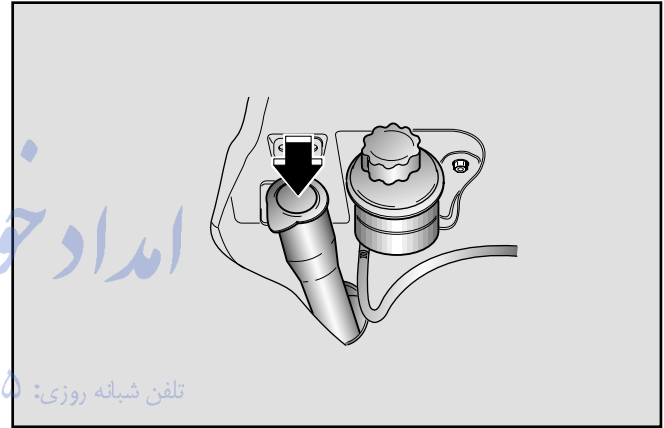

MMSA7012

The reservoir is translucent so that you can check the level with a quick visual inspection.

Check the fluid level in the washer fluid reservoir and add fluid if necessary. Plain water may be used if washer fluid is not available. In cold climates, use washer solvent with antifreeze to prevent freezing.

## **WARNING**

- **Do not use radiator coolant or antifreeze in the washer fluid reservoir.**
- **Radiator coolant can severely obscure visibility when sprayed on the windshield and may cause loss of vehicle control or damage to paint and body trim.**
- **Windshield washer fluid agents contain some amounts of alcohol and can be flammable under certain circumstances. Do not allow sparks or flame to contact the washer fluid or the washer fluid reservoir. Damage to the vehicle or it's occupants could occur.**
- **Windshield washer fluid is poisonous to humans and animals. Do not drink and avoid contacting windshield washer fluid. Serious injury or death could occur.**

## **Body Lubrication**

All moving points of the body, such as door hinges, hood hinges, and locks, should be lubricated each time the engine oil is changed. Use a non-freezing lubricant on locks during cold weather.

Make sure the engine hood secondary latch keeps the hood from opening when the primary latch is released.

## AIR CLEANER

### *Element Replacement*

Your vehicle is equipped with a viscous paper air cleaner filter. It must be replaced when necessary, and should not be cleaned and reused.

- 1 Remove the four (4) air cleaner cover attaching clips.
2. Wipe the inside of the air cleaner housing with a damp cloth.

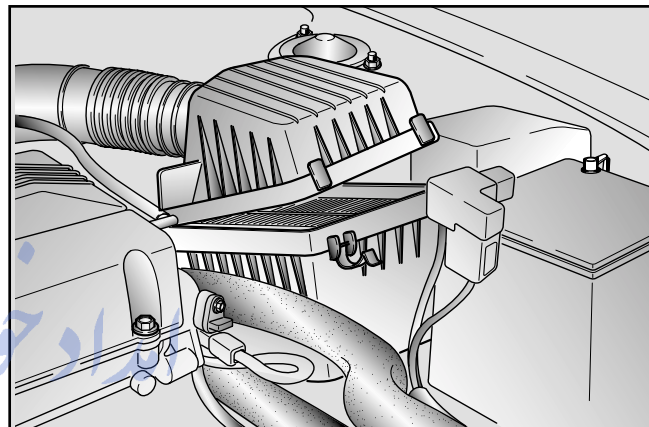

MMSA7013

3. Replace the air cleaner element.

فارس خودرو فارما  
تلفن شبانه روزی: ۰۲۱-۸۸۸۶۲۰۸۳  
FarmaSOS.com

# Maintenance

---

4. Install the cover. Install and tighten the (4) cover attaching clips.

Replace the element according to the Scheduled Maintenance Section.

*If the vehicle is operated in extremely dusty or sandy areas, replace the element more frequently than the usual recommended intervals. (Refer to Schedule 2 – Severe Maintenance in this section.)*

## WARNING

- Driving with the air cleaner removed can cause backfiring through the intake and could cause a fire in the engine compartment.

امداد خودرو فارما

تلفن شبانه روزی: ۰۲۱-۸۸۸۶۲۰۸۵

FarmaSOS.com

---

## WIPER BLADES

### *Windshield Wiper Blade Maintenance*

Contamination of either the windshield and wiper blades with foreign matter such as insects, tree sap, and hot wax treatments used by some commercial car washes can reduce wiper effectiveness. If the blades are not wiping properly, clean both the window and the blades with a good cleaner or mild detergent, and rinse thoroughly with clean water.

### *Windshield Wiper Blade Replacement*

When the wipers no longer clean adequately, the blades may be worn or cracked, and require replacement.

#### **\* NOTICE**

To prevent damage to the wiper blades, do not use gasoline, kerosene, paint thinner, or other solvents to clean them.

#### **\* NOTICE**

To prevent damage to the wiper arms or other components, do not attempt to move the wipers manually.

FarmaSOS.com

# Maintenance

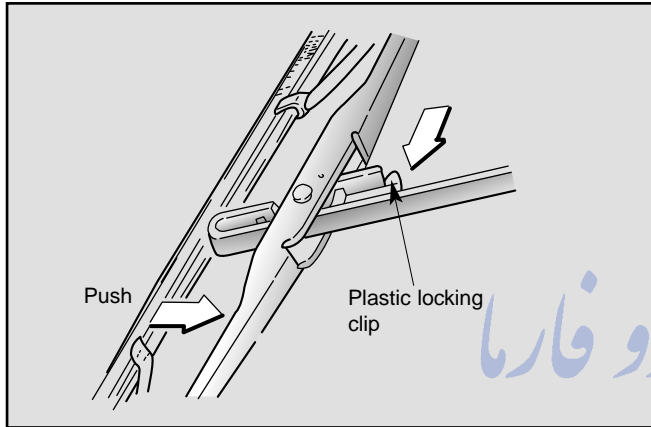

MMSA7014

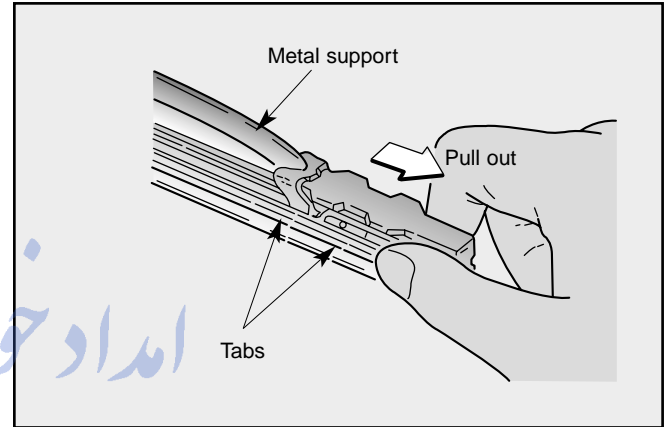

MMSA7015

1. Raise the wiper arm and turn the wiper blade assembly to expose the plastic locking clip. Compress the clip and slide the blade assembly downward; then lift it off the arm.
2. Firmly grasp the end of the rubber blade and pull until the tabs are free of the metal support.

FarmaSOS.com

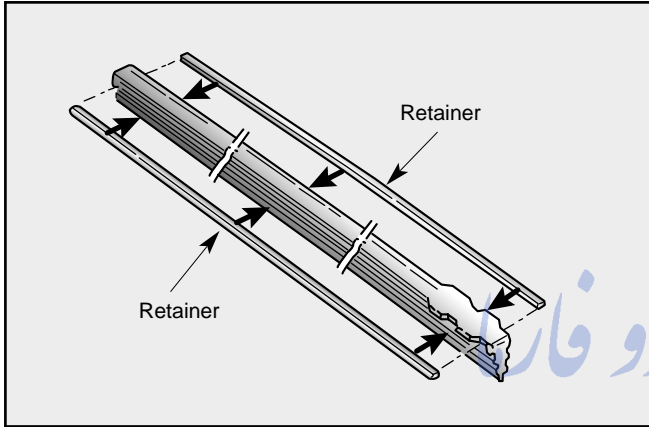

MMSA7016

3. Remove the metal retainers from the rubber blade and install them in the new rubber blade.

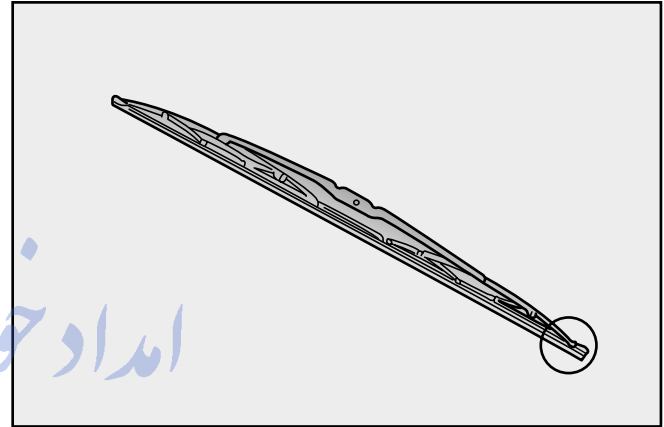

MMSA7017

4. Carefully insert a new rubber blade and install the blade assembly.

*Install the blade with the tabs facing towards the bottom of the wiper arm.*

**\* NOTICE**

Do not bend the metal retainers.

# Maintenance

## BATTERY

### **WARNING - Battery Dangers**



Always read the following instructions carefully when handling a battery.



Keep lighted cigarettes and all other flames or sparks away from the battery.



Hydrogen, which is a highly combustible gas, is always present in battery cells and may explode if ignited.



If any electrolyte gets into your eyes, flush your eyes with clean water for at least 15 minutes and get immediate medical attention. If possible, continue to apply water with a sponge or cloth until medical attention is received.

If electrolyte gets on your skin, thoroughly wash the contacted area. If you feel a pain or a burning sensation, get medical attention immediately.

*(Continued)*

*(Continued)*



Keep batteries out of the reach of children because batteries contain highly corrosive SULFURIC ACID. Do not allow battery acid to contact your skin, eyes, clothing or paint finish.



Wear eye protection when charging or working near a battery. Always provide ventilation when working in an enclosed space.

- When lifting a plastic-cased battery, excessive pressure on the case may cause battery acid to leak, resulting in personal injury. Lift with a battery carrier or with your hands on opposite corners.
- Never attempt to charge the battery when the battery cables are connected.
- The electrical ignition system works with high voltage. Never touch these components with the engine running or the ignition switched on.

## Battery Maintenance

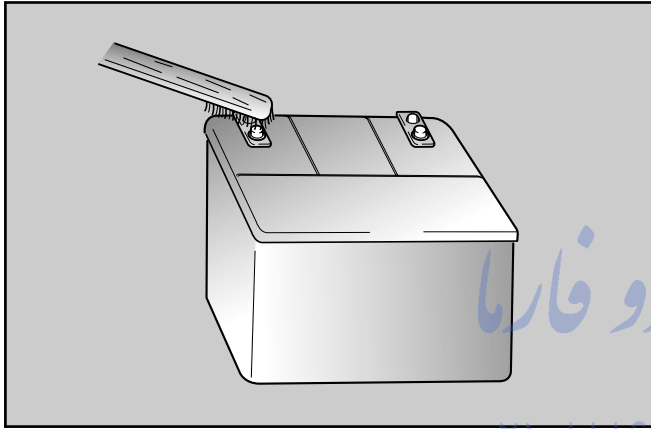

- Rinse any spilled electrolyte from the battery immediately with a solution of water and baking soda.
- If the vehicle is not going to be used for an extended time, disconnect the battery cables.

تلفن شبانه روزی: ۰۸۵-۲۰۳۴۰۳۴۰-۰۲۱ MMSA7034

For optimal battery performance:

- Keep the battery securely mounted.
- Keep the battery top clean and dry.
- Keep the terminals and connections clean, tight, and coated with petroleum jelly or terminal grease.

FarmaSOS.com

# Maintenance

---

## ***Battery Recharging***

Your vehicle has a maintenance-free, calcium-based battery.

- If the battery becomes discharged in a short time (because, for example, the headlights or interior lights were left on while the vehicle was not in use), recharge it by slow charging (trickle) for 10hours.
- If the battery gradually discharges because of high electric load while the vehicle is being used, recharge it at 20-30A for two hours.

## **⚠ WARNING - Recharging Battery**

**When recharging the battery, observe the following precautions:**

- **The battery must be removed from the vehicle and placed in an area with good ventilation.**
- **Do not allow cigarettes, sparks, or flame near the battery.**
- **Watch the battery during charging, and stop or reduce the charging rate if the battery cells begin gassing (boiling) violently or if the temperature of the electrolyte of any cell exceeds 120°F (49°C).**
- **Wear eye protection when checking the battery during charging.**

***(Continued)***

*(Continued)*

- **Disconnect the battery charger in the following order.**
  1. **Turn off the battery charger main switch.**
  2. **Unhook the negative clamp from the negative battery terminal.**
  3. **Unhook the positive clamp from the positive battery terminal.**

**\* NOTICE**

- Before performing maintenance or recharging the battery, turn off all accessories and stop the engine.
- The negative battery cable must be removed first and installed last when the battery is disconnected.

تلفن شبانه روزی: ۰۲۱-۸۸۸۶۲۰۸۵

FarmaSOS.com

# Maintenance

## TIRES AND WHEELS

### *Tire Care*

For proper maintenance, safety, and maximum fuel economy, you must always maintain recommended tire inflation pressures and stay within the load limits and weight distribution recommended for your vehicle. The load limits appear on the sidewalls of the tires.

### *Inflation Pressures*

All tire pressures (including the spare) should be checked monthly when the tires are cold. "Cold Tires" means the vehicle has not been driven for at least three hours or driven less than one mile (1.2 km). Recommended pressures must be maintained for optimum vehicle handling, and minimum tire wear.

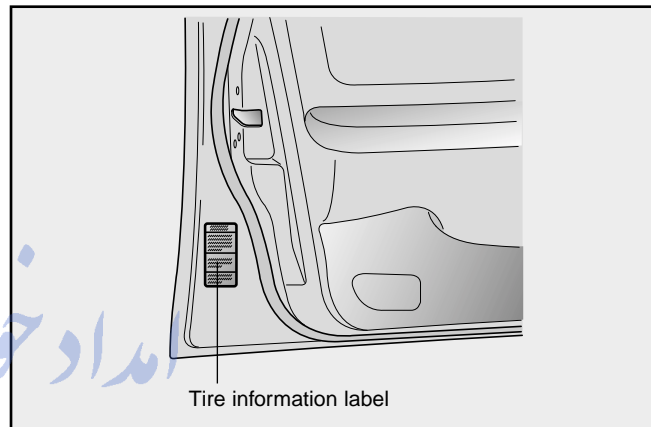

MMSA7019

All specifications (sizes and pressures) can be found on a label attached to the front driver side door.

The correct tire pressure is 30 psi (210 kPa).

The compact spare should be maintained at 60 psi (420 kPa).

## **⚠ WARNING - Tire Inflation**

Over inflation or under inflation can reduce tire life, adversely affect vehicle handling, and lead to sudden tire failure. You could lose control and have a serious accident. Follow all the guidelines about proper tire maintenance.

- Warm tires normally exceed recommended cold tire pressures by 4 to 6 psi (28 to 41 kPa). Do not release air from warm tires to adjust the pressure. The tires will be underinflated.

*(Continued)*

*(Continued)*

- Underinflation results in excessive wear, poor handling, reduced fuel economy, and possibility of blowouts from overheated tires. Also, low tire pressure can cause poor seating of the tire bead. If the tire pressure is excessively low, wheel deformation and/or tire separation is possible. So keep you tire pressures at the proper levels. If a tire frequently needs refilling, have it checked by an authorized Kia dealer or a competent tire shop.
- Overinflation produces a harsh ride, handling problems, excessive wear at the center of the tire tread, and a greater possibility of damage from road hazards.

# Maintenance

## ***Tire Rotation***

To equalize tread wear, it is recommended that the tires be rotated every 7,500 miles (12000 km) or sooner if irregular wear develops.

During rotation, check the tires for correct balance.

When rotating tires, check for uneven wear and damage. Abnormal wear is usually caused by incorrect tire pressure, improper wheel alignment, out-of-balance wheels, severe braking or severe cornering. Look for bumps or bulges in the tread or side of tire. Replace the tire if you find either of these conditions. Replace tires showing fabric or cord. After rotation, be sure to bring the front and rear tire pressures to specification and check lug nut tightness.

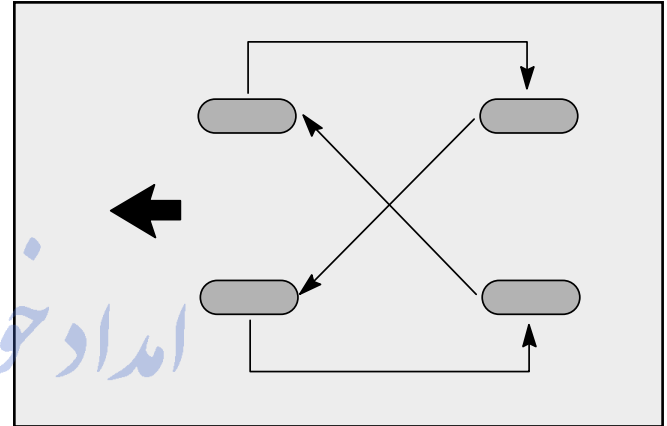

*Disc brake pads should be inspected for wear whenever tires are rotated.*

### **\* NOTICE**

Radical tires having asymmetric tread patterns should only be rotated with the tire on the side of the vehicle.

## Tire Replacement

If the tire is worn evenly, a tread wear indicator will appear as a solid band 1/2 inch wide (12.7 mm) across the the tread. This shows there is less than 1/16 inch (1.6 mm) of tread left on the tire. Replace the tire when this happens.

Do not wait for the band to appear across the entire tread before replacing the tire.

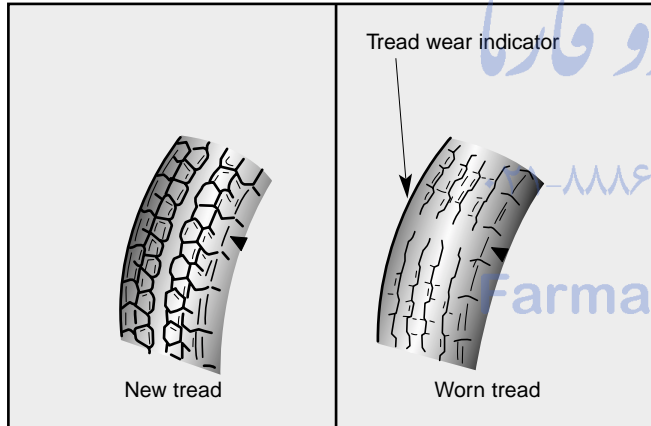

MMSA7021

## Compact Spare Tire Replacement (If equipped)

A compact spare tire has a shorter tread life than a regular size tire. Replace it when you can see the tread wear indicator bars on the tire. The replacement compact spare tire should be the same size and design tire as the one provided with your new Kia and should be mounted on the same compact spare tire wheel. The compact spare tire is not designed to be mounted on a regular size wheel, and the compact spare tire wheel is not designed for mounting a regular size tire.

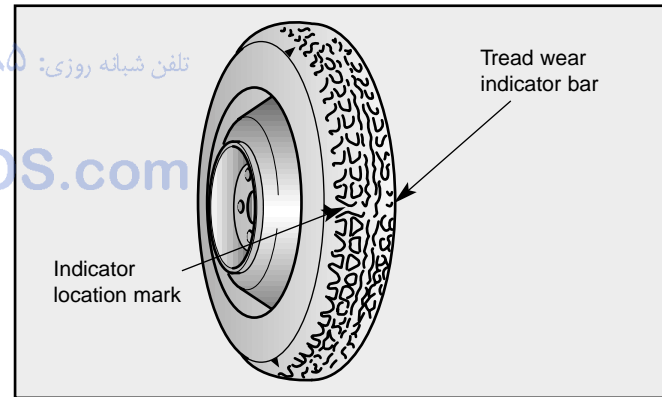

MMSA7022

# Maintenance

## ***Wheel Alignment and Tire Balance***

The wheels on your vehicle were aligned and balanced carefully at the factory to give you the longest tire life and best overall performance.

In most cases, you will not need to have your wheels aligned again. However, if you notice unusual tire wear or your vehicle pulling one way or the other, the alignment may need to be reset. If you notice your vehicle vibrating when driving on a smooth road, your wheels may need to be rebalanced.

### **\* NOTICE**

Improper wheel weights can damage your vehicle's aluminum wheels. Use only approved wheel weights.

### **⚠ WARNING - Tire Inflation**

- **Driving on worn-out tires or mismatched tires is very hazardous. Worn-out tires reduce braking effectiveness, steering accuracy, and traction. You are also more likely to have a blowout on a worn-out tire. Replace any tire showing signs of being worn out.**
- **When replacing tires, never mix radial, bias-belted, and bias-type tires. All four tires should be of the same size, design and construction. Use only the tire sizes listed on the Tire Label located below the door striker on the driver's side. Make sure that all tires and wheels are the same size and have the same load-carrying capacity. Use only tire and wheel combinations recommended on the Tire Label or by an authorized Kia dealer. Be sure the tire size matches the wheel size.**

- The use of any other tire size or type may seriously affect ride, handling, ground clearance, tire clearance, and speedometer calibration.
- It is best to replace all four tires at the same time. If that is not possible or necessary, then replace the two front or two rear tires as a pair. Replacing just one tire can seriously affect your vehicle's handling.

### ***Wheel Replacement***

When replacing the metal wheels for any reason, make sure the new wheels are equivalent to the original factory units in diameter, rim width and offset.

#### **⚠ WARNING**

A wheel that is not the correct size may adversely affect wheel and bearing life, braking and stopping abilities, handling characteristics, ground clearance, body-to-tire clearance, snow chain clearance, speedometer calibration, headlight aim and bumper height.

# Maintenance

---

## ***Tire Size Designation***

A tire's sidewall is marked with a tire size designation. You will need this information when selecting replacement tires for your car. The following explains what the letters and numbers in the tire size designation mean.

Example tire size designation: **P205/60R15 82T**  
(these numbers are provided as an example only; your tire size designator could vary depending on your vehicle.)

**P** – Applicable vehicle type (tires marked with the prefix “P” are intended for use on passenger cars; however, not all tires have this marking).

**205** – Tire width in millimeters.

**60** – Aspect ratio. The tire's section height as a percentage of its width.

**R** – Tire construction code (Radial).

**15** – Rim diameter in inches.

**82** – Load Index, a numerical code associated with the maximum load the tire can carry.

**T** – Speed Rating Symbol. See the speed rating chart in this section for additional information.

## ***Wheel Size Designation***

Wheels are also marked with important information that you need if you ever have to replace one. The following explains what the letters and numbers in the wheel size designation mean.

Example wheel size designation: 15 x 6J

**15** – Rim width in inches.

**6** – Rim diameter in inches.

**J** – Rim contour designation.

تلفن شبانه روزی: ۰۲۱-۸۸۸۶۲۰۸۵

FarmaSOS.com

---

## ***Tire Speed Ratings***

The chart below shows many of the different speed ratings currently being used for passenger car tires. The speed rating symbol is part of the tire size designation on the sidewall of the tire. This symbol corresponds to that tire's designed maximum safe operating speed.

<b>Speed Rating Symbol</b>	<b>Maximum Speed</b>
S	112 mph (180 km/h)
T	118 mph (190 km/h)
H	130 mph (210 km/h)
V	149 mph (240 km/h)
Z	Above 149 mph (240 km/h)

## ***Uniform Tire Quality Grading***

The following information relates to the tire grading system developed by the National Highway Traffic Safety Administration (NHTSA) for grading tires by tread wear, traction and temperature performance.

### **Tread Wear**

The tread wear grade is a comparative rating based on the wear rate of the tire when tested under controlled conditions on a specified government test course. For example, a tire graded 150 would wear one-and-a-half times as well on the government course as a tire graded 100.

The relative performance of tires depends upon the actual conditions of their use. However, performance may differ from the norm because of variations in driving habits, service practices and differences in road characteristics and climate.

# Maintenance

---

These grades are molded on the side-walls of passenger vehicle tires. The tires available as standard or optional equipment on Kia vehicles may vary with respect to grade.

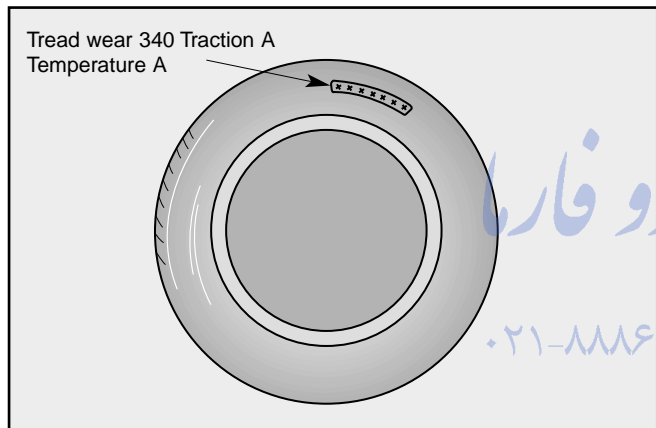

MMSA7023

## Traction – A, B & C

The traction grades, from highest to lowest, are A, B and C. The grades represent the tire's ability to stop on wet pavement as measured under controlled conditions on specified government test surfaces of asphalt and concrete. A tire marked C may have poor traction performance.

## Temperature – A, B & C

The temperature grades are A (the highest), B and C. The grades represent the tire's resistance to the generation of heat and its ability to dissipate heat when tested under controlled conditions on a specified laboratory test wheel. Sustained high temperature can cause the material of the tire to degenerate and reduce tire life, and excessive temperature can lead to sudden tire failure. Grade C corresponds to a level of performance which all passenger vehicle tires must meet under the Federal Motor Vehicle Safety Standard No. 109. Grades A and B represent higher levels of performance on the laboratory test wheel than the minimum required by the law.

### **⚠ WARNING - Tire Temperature**

The temperature grade for the tire on your vehicle is established for a tire that is properly inflated and not overloaded. Excessive speed, underinflation, or excessive loading, either separately or in combination, can cause heat build-up and possible sudden tire failure. This can cause loss of vehicle control and serious injury or death.

## **BULB REPLACEMENT**

### *Headlight Replacement*

### **⚠ WARNING - Halogen Bulbs**

- Halogen bulbs contain pressurized gas that will produce flying pieces of glass if broken.
- Always handle them carefully, and avoid scratches and abrasions. If the bulbs are lit, avoid contact with liquids. Never touch the glass with bare hands. Residual oil may cause the bulb to overheat and burst when lit. A bulb should be operated only when installed in a headlight.
- If a bulb becomes damaged or cracked, replace it immediately and carefully dispose of it.
- Wear eye protection when changing a bulb. Allow the bulb to cool before handling it.

# Maintenance

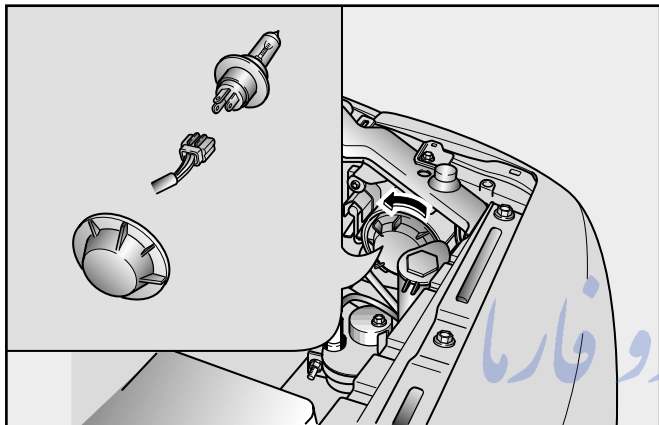

MMSA7024

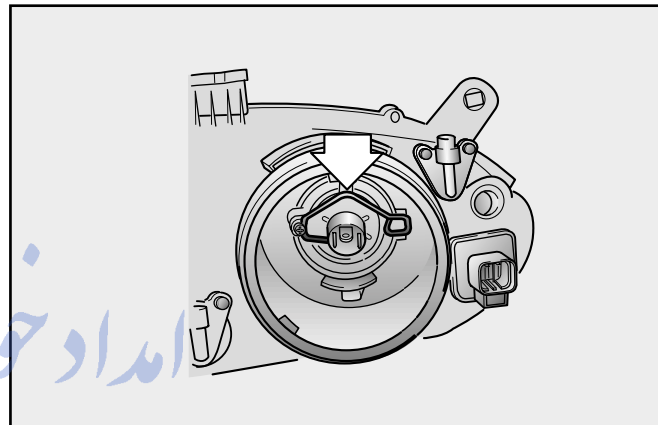

MMSA7025

1. Remove the headlight bulb cover by turning it counterclockwise.
2. Disconnect the headlight bulb electrical connector.
3. Unsnap the headlight bulb retaining wire.
4. Remove the bulb from the three (3) slots on the headlight assembly.
5. Install a new headlight bulb in the three (3) slots on the headlight assembly and snap the headlight bulb retaining wire into position.
6. Connect the headlight bulb electrical connector.
7. Install the headlight bulb cover by turning it clockwise.

## Front Turn Signal / Position Light Bulb Replacement

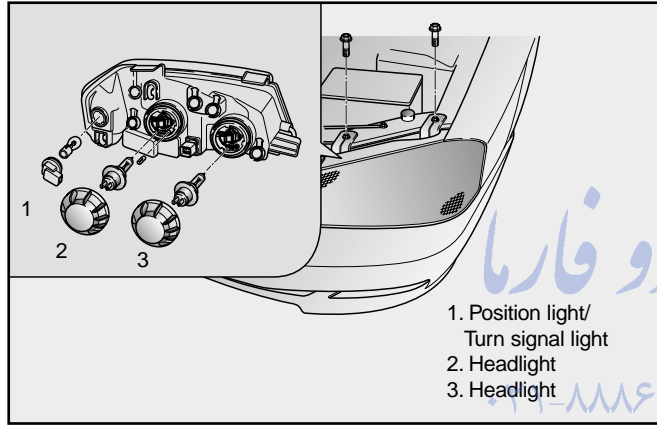

MMSA7026

1. Remove the bolts from the headlight assembly.

## Front Fog Light Replacement (If equipped)

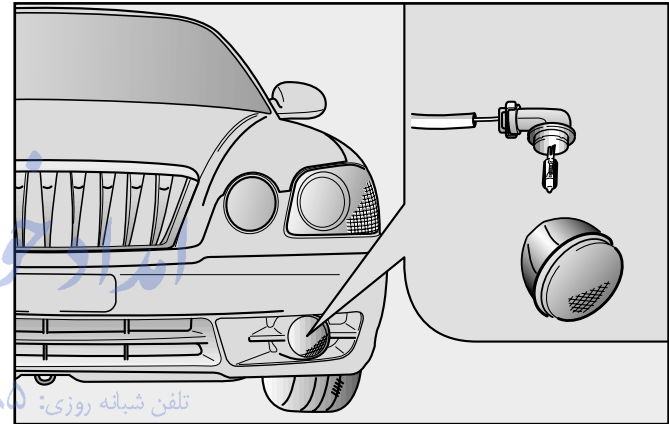

MMSA7027

1. Turn the bulb socket counter- clockwise and remove the bulb socket.
2. Insert a new bulb in socket.
3. Install the bulb socket.

# Maintenance

## Rear Combination Light Bulb Replacement

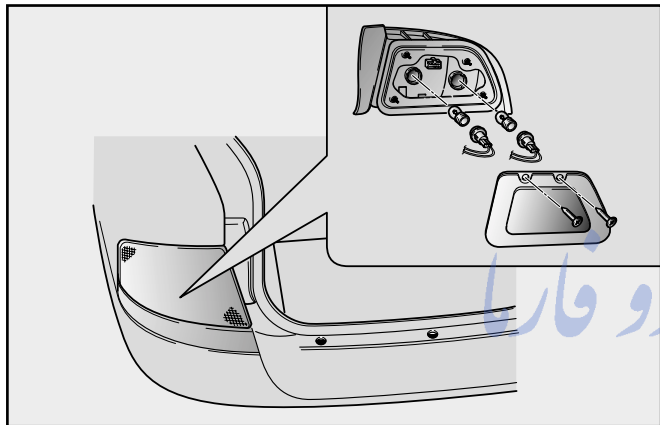

1. Using a cross-tip screwdriver, remove the cover.
2. Turn the bulb socket counterclockwise and remove it from the housing.
3. Push the bulb in, then rotate it one quarter turn counterclockwise and remove the bulb from the socket.

4. Insert a new bulb in the socket, then push the bulb in and rotate it one quarter turn clockwise to lock the bulb in place.
5. Re-install the bulb socket into the rear combination light assembly and rotate it one-quarter turn clockwise to lock the socket in place.
6. Re-install the cover.

MMSA7028

تلفن شبانه روزی: ۰۸۵-۰۲۱-۰۲۱-۰۲۱

ParmaSOS.com

## Dome Light Bulb Replacement

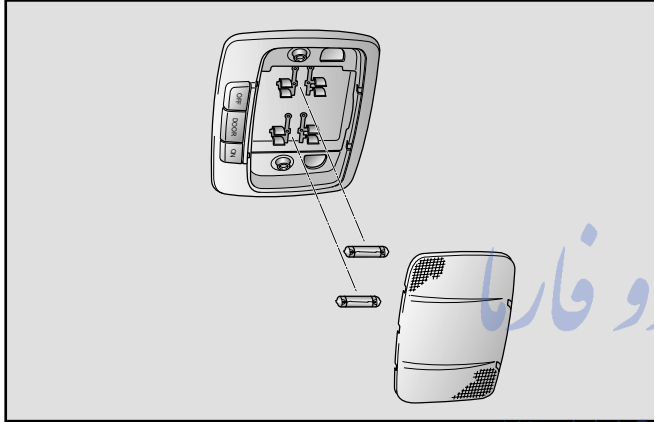

### **⚠ WARNING**

Prior to working on the Dome Light, ensure that the “OFF” button is depressed to avoid burning your fingers or receiving an electric shock.

1. Using a flat-blade screwdriver, gently pry the lens from the dome light housing.
2. Carefully pull the bulb out of the socket.
3. Insert a new bulb in the socket.
4. Align the lens tabs with the dome light housing notches and snap the lens into place.

تلفن شبانه روزی: ۰۸۵-۰۲۱-۰۲۱-۰۲۱

FarmaSOS.com



## Center High-Mounted Stoplight Bulb Replacement

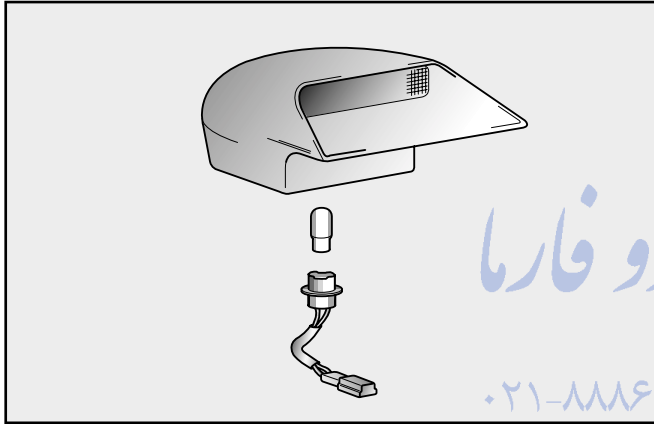

1. Remove the cover and turn the bulb socket counterclockwise and remove it from the housing.
2. Push the bulb in, then rotate it one-quarter turn counterclockwise and remove the bulb from the socket.

3. Insert a new bulb in the socket, then push the bulb in and rotate it one-quarter turn clockwise.
4. Re-install the bulb socket into the cover and rotate it one-quarter turn clockwise to lock the socket in place.
5. Re-install the cover.

امداد خودرو فارما

تلفن شبانه روزی: ۰۲۱-۸۸۶۲۰۸۵

FarmaSOS.com

# Maintenance

---

## **Trunk Room Light Bulb Replacement (If equipped)**

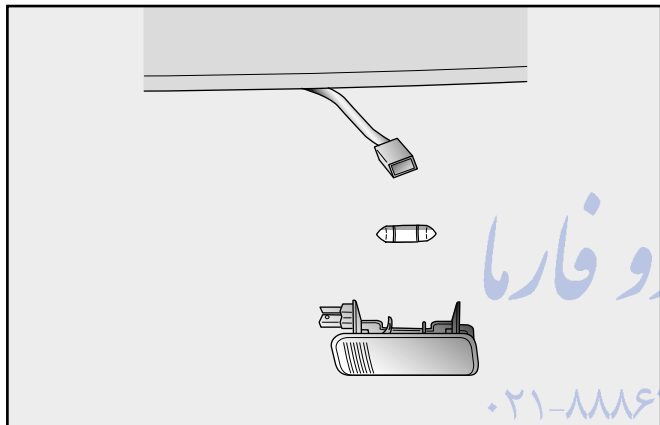

MMSA7031

1. Remove the trunk room lamp cover using flat blade screw driver.
2. After replacement of bulb, install the cover.

## **LUBRICANT SPECIFICATIONS**

### ***Recommended Lubricants***

To help achieve proper engine and powertrain performance and durability, use only lubricants of the proper quality. The correct lubricants also help promote engine efficiency that results in improved fuel economy.

Engine oils labeled Energy Conserving Oil are now available. Along with other additional benefits, they contribute to fuel economy by reducing the amount of fuel necessary to overcome engine friction. Often, these improvements are difficult to measure in everyday driving, but in a year's time, they can offer significant cost and energy savings.

---

These lubricants and fluids are recommended for use in your vehicle.

<b>Lubricant</b>	<b>Classification</b>
Engine oil <sup>*1)</sup>	API Service SJ, SL or above, ILSAC GF-3 or above
Manual transaxle oil	API Service GL-4 (SAE 75W-85)
Automatic transaxle fluid	SKATF SP-III or DIAMOND ATF SP-III or other brands meeting the SP-III specification approved by Kia Motors Corp.
Power steering fluid	PSF IV
Brake/clutch fluid	SAE J1703 or FMVSS116 DOT-3 or DOT-4

\*1) Refer to the recommended SAE viscosity numbers on this page.

امداد خودرو فارما  
تلفن شبانه روزی: ۰۲۱-۸۸۸۶۲۰۸۵

FarmaSOS.com

# Maintenance

## Recommended SAE Viscosity Number

### \* NOTICE

Always be sure to clean the area around any filler plug, drain plug, or dipstick before checking or draining any lubricant. This is especially important in dusty or sandy areas and when the vehicle is used on unpaved roads. Cleaning the plug and dipstick areas will prevent dirt and grit from entering the engine and other mechanisms that could be damaged.

Engine oil viscosity (thickness) has an effect on fuel economy and cold weather operating (starting and oil flow). Lower viscosity engine oils can provide better fuel economy and cold weather performance, however, higher viscosity engine oils are required for satisfactory lubrication in hot weather. Using oils of any viscosity other than those recommended could result in engine damage. When choosing an oil, consider the range of temperature your vehicle will be operated in before the next oil change. Proceed to select the recommended oil viscosity from the chart.

تلفون شماره روزی: ۰۲۱-۸۸۶۲۰۸۵

Temperature Range for SAE Viscosity Numbers

Temperature	°C	-30	-20	-10	0	10	20	30	40	50
	(°F)	-10	0	20	40	60	80	100	120	
Engine Oil *1		10W-30								
		5W-20, 5W-30								

1. For better fuel economy, it is recommended to use the engine oil of a viscosity grade SAE 5W-20,5W-30 (API SJ,SL / ILSAC GF-3). However, the engine oil is not available in your country, select the proper engine oil using the engine oil viscosity chart.

---

## EXTERIOR CARE

### *Exterior General Caution*

It is very important to follow the label directions when using any chemical cleaner or polish. Read all warning and caution statements that appear on the label.

### *Finish Maintenance*

#### *Washing*

To help protect your vehicle's finish from rust and deterioration, wash it thoroughly at least once a month with lukewarm or cold water.

Pay special attention to the removal of any accumulation of salt, dirt, mud, and other foreign materials. Make sure the drain holes in the lower edges of the doors and rocker panels are kept clear and clean.

Insects, tar, tree sap, bird droppings, industrial pollution and similar deposits can damage your vehicle's finish if not removed immediately.

Even prompt washing with plain water may not completely remove all these deposits. A mild soap, safe for use on painted surfaces, may be used.

After washing, rinse the vehicle thoroughly with lukewarm or cold water. Do not allow soap to dry on the finish.

#### **\* NOTICE**

Do not use strong soap, chemical detergents or hot water, and do not wash the vehicle in direct sunlight or when the body of the vehicle is warm.

#### **⚠ WARNING**

**After washing the vehicle, test the brakes while driving slowly to see if they have been affected by water. If braking performance is impaired, dry the brakes by applying them lightly while maintaining a slow forward speed.**

## **⚠ WARNING - Water Washing in Engine Compartment**

Water washing in the engine compartment may cause failure of electrical circuits. Systems of your vehicle could fail when you need them. Wash your engine compartment carefully. Check your vehicle's features before driving again.

## **Waxing**

Wax the vehicle when water will no longer bead on the paint.

Always wash and dry the vehicle before waxing. Use good quality liquid or paste wax, and follow the manufacturer's instructions. Wax all metal trim to protect it and to maintain its luster.

*Removing oil, tar, and similar materials with a spot remover will usually strip the wax from the finish. Be sure to re-wax these areas even if the rest of the vehicle does not yet need waxing.*

## **\* NOTICE**

- Wiping dust or dirt off the body with a dry cloth will scratch the finish.
- Do not use steel wool, abrasive cleaners, or strong detergents containing high alkaline or caustic agents on chrome-plated or anodized aluminum parts. This may result in damage to the protective coating and cause discoloration or paint deterioration.

## **Finish Damage Repair**

Deep scratches or stone chips in the painted surface must be repaired promptly. Exposed metal will quickly rust and may develop into a major repair expense.

## **\* NOTICE**

If your vehicle is damaged and requires any metal repair or replacement, be sure the body shop applies anti-corrosion materials to the parts repaired or replaced.

---

### ***Bright-Metal Maintenance***

- To remove road tar and insects, use a tar remover, not a scraper or other sharp object.
- To protect the surfaces of bright-metal parts from corrosion, apply a coating of wax or chrome preservative and polish to a high luster.
- During winter weather or in coastal areas, cover the bright metal parts with a heavier coating of wax or preservative. If necessary, coat the parts with non-corrosive petroleum jelly or other protective compound.

### ***Underbody Maintenance***

Corrosive materials used for ice and snow removal and dust control may collect on the underbody. If these materials are not removed, accelerated rusting can occur on underbody parts such as the fuel lines, frame, floor pan and exhaust system, even though they have been provided with rust protection.

Thoroughly flush the vehicle underbody and wheel openings with lukewarm or cold water once a month, after off-road driving (for four-wheel drive vehicles) and at the end of each winter. It will do more harm than good to wet down the road grime without removing it. The lower edges of doors, rocker panels, and frame members have drain holes that should not be allowed to clog with dirt; trapped water in these areas can cause rusting.

# Maintenance

---

## ***Aluminum Wheel Maintenance***

The aluminum wheels are coated with a clear protective finish.

- *Do not use any abrasive cleaner, polishing compound, solvent, or wire brushes on aluminum wheels. They may scratch or damage the finish.*
- *Use only a mild soap or neutral detergent, and rinse thoroughly with water. Also, be sure to clean the wheels after driving on salted roads. This helps prevent corrosion.*
- *Avoid washing the wheels with high-speed car wash brushes.*

## **INTERIOR CARE**

### ***Interior General Precautions***

Prevent caustic solutions such as perfume and cosmetic oil from contacting the dashboard because they may cause damage or discoloration. If they do contact the dashboard, wipe them off immediately. See the instructions that follow for the proper way to clean vinyl.

### ***Cleaning the Upholstery and Interior Trim*** **Vinyl**

Remove dust and loose dirt from vinyl with a whisk broom or vacuum cleaner. Clean vinyl surfaces with a vinyl cleaner.

FarmaSOS.com

---

## Fabric

Remove dust and loose dirt from fabric with a whisk broom or vacuum cleaner. Clean with a mild soap solution recommended for upholstery or carpets. Remove fresh spots immediately with a fabric spot cleaner. If fresh spots do not receive immediate attention, the fabric can be stained and its color can be affected. Also, its fire-resistant properties can be reduced if the material is not properly maintained.

### CAUTION

*Using anything but recommended cleaners and procedures may affect the fabric's appearance and fire-resistant properties.*

## ***Cleaning the Lap/Shoulder Belt Webbing***

Clean the belt webbing with any mild soap solution recommended for cleaning upholstery or carpet. Follow the instructions provided with the soap. Do not bleach or re-dye the webbing because this may weaken it.

## ***Cleaning the Interior Window Glass***

If the interior glass surfaces of the vehicle become fogged (that is, covered with an oily, greasy or waxy film), they should be cleaned with glass cleaner. Follow the directions on the glass cleaner container.

### \* NOTICE

Do not scrape or scratch the inside of the rear window. This may result in damage to the rear window defroster grid.

# Maintenance

## HEADLIGHT AIMING ADJUSTMENT

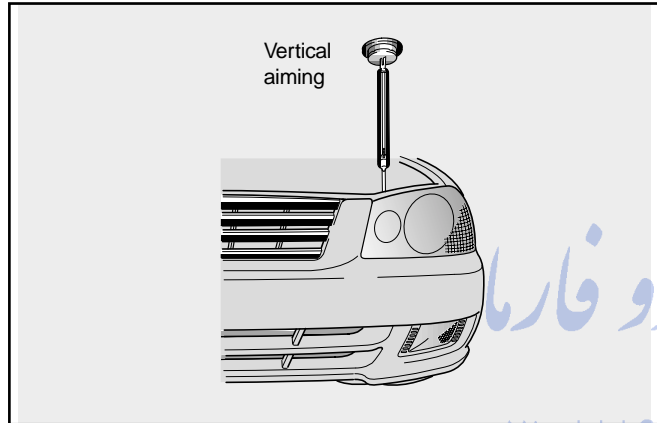

Before performing aiming adjustment, make sure of the following.

1. Keep all tires inflated to the correct pressure.
2. Place the vehicle on level ground and press the front bumper & rear bumper down several times.
3. See that the vehicle is unloaded (except for full levels of coolant, engine oil and fuel, and spare tire, jack, and tools). Have the driver or equivalent weight in driver's seat.

4. Clean the head light lens and turn on the headlight (Low beam).
5. Open the hood.
6. Draw the vertical line (through the center of each headlight) and the horizontal line (through the center of each headlight) on the aiming screen.
  - 1) Horizontal line dimension from ground: 24.72 in (628 mm)
  - 2) Distance between each vertical line : 49.17 in (1,306 mm)And then, draw the parallel line at 1.18 in (30 mm) place under the horizontal line.
7. Adjust each cut-off line of the low beam to the parallel line with a Phillips screwdriver

**VERTICAL AIMING.**

## Adjustment After Headlight Assembly Replacement

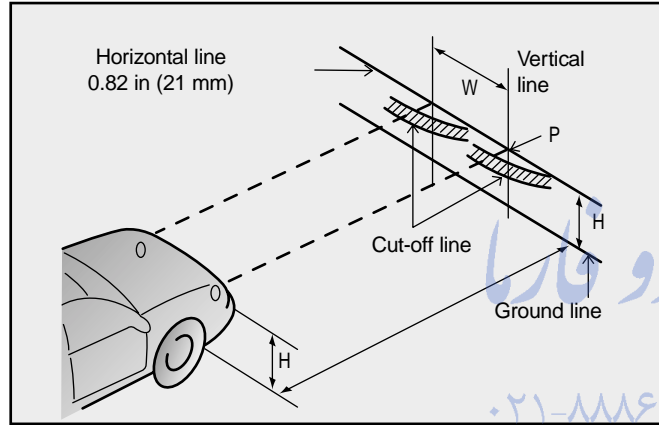

If the vehicle has had front body repair and the headlight assembly has been replaced, the headlight aiming should be checked using the aiming screen as shown in the illustration. Turn on the headlight switch. (Low Beam Position)

1. Adjust headlights so that main axis of light is parallel to center line of the body and is aligned with point "P" shown in the illustration.

2. Dotted lines in the illustration show center of headlights.

"H";

Horizontal center line of headlights from ground : 24.72 in (628 mm)

"W";

Distance between each headlight center: 49.17 in (1,306 mm)

"L";

Distance between the headlights and the wall that the lights are tested against: 118.11 in (3,000 mm)

تلفن شبانه روزی: ۰۲۱-۸۸۶۲۰۸۵

FarmaSOS.com

---

## SPECIFICATIONS

Specifications ..... 8-2

امداد خودرو فارما

تلفن شبانه روزی: ۰۲۱-۸۸۸۶۲۰۸۵

FarmaSOS.com

# Specifications

---

## SPECIFICATIONS

The specifications given here are for general information only. Please check with an authorized Kia dealer for more precise and more up-to-date information.

### DIMENSIONS

Unit: in (mm)

Item	4 Door Sedan
Overall length	185.8 (4720)
Overall width	71.4 (1815)
Overall height	55.5 (1410)
Front tread	60.6 (1540)
Rear tread	59.8 (1520)
Wheelbase	106.3 (2700)

## WEIGHTS

Refer to the label describing GVWR & GAWR weights attached to your vehicle.  
(see page 5-14, Label information)

### AIR CONDITIONER

Refrigerant complies with SAEJ639	R-134a
Maximum operating charge	20~22oz (650±25g)

تلفن شبانه روزی: ۰۸۵ ۸۸۸۶۲۰۸۵  
FarmaSOS.com

## TIRES

	Size	
Tire	P205/60R15	*T120/70D15 or T125/70R15
	P205/55R16 (if equipped)	
Pressure	Inflation Pressure psi (kPa, kg/cm <sup>2</sup> )	
	30 (210, 2.1)	60 (420, 4.2)

\*Spare tire (Temporary spare)

## GEAR RATIO

Item	M/T		A/T
	2400cc 4-cyl	2700cc V-6	2400cc 4-cyl / 2700cc V-6
1st	3.455	3.231	2.842
2nd	1.952	1.952	1.529
3rd	1.296	1.296	1.000
4th	0.943	0.943	0.712
5th	0.775	0.775	
Reverse	3.455	3.455	2.480

M/T : Manual Transaxle

A/T : Automatic Transaxle

## LIGHT BULBS

	Light Bulb	Wattage	
Front	Headlights	LOW	55
		HIGH	65
	Turn signal/Position lights		28/8
	Fog lights (if equipped)		55
	Side marker lights (if equipped)		5
Rear	Stop and tail lights		28/8
	Turn signal lights		27
	Backup lights		16
	High mounted stop lights		16
	Side marker lights (if equipped)		5
	License plate lights		5
	Interior lights		10
Interior	Luggage compartment light (If equipped)	5	

# Specifications

## ENGINE

Item	2400cc 4-cyl	2700cc V-6
Borex stroke (mm)	86.5x100	86.7x75
Displacement (cc)	2351	2656
Compression Ratio	10±0.2	10±0.2
Firing order	1-3-4-2	1-2-3-4-5-6
Idle speed (rpm)	800±100	700±100

## CAPACITIES

US qt (Liter)

Item		2400cc 4-cyl	2700cc V-6
Engine Oil		4.5 (4.3)	5.1 (4.8)
Coolant	M/T	6.7 (6.3)	7.3 (6.9)
	A/T	6.9 (6.5)	7.5 (7.1)
Transaxle Oil	M/T	2.2 (2.1)	2.2 (2.1)
	A/T	8.2 (7.8)	8.2 (7.8)
Fuel tank		17.2 US gal (65L)	

## ELECTRICAL SYSTEM

Item		2400cc 4-cyl	2700cc V-6
Battery		MF68AH	MF 68AH
Alternator		13.5V-95A/13.5V-110A (if equipped)	
Starter	M/T	12V-1.2Kw	
	A/T	12V-1.2Kw	
Spark plug	Gap in (mm)	0.039~0.043 (1.0~1.1)	0.039~0.043 (1.0~1.1)
	Type	PGR5C-11 or RN10PYP4	PFR5N-11 or RC10PYPB4

## CLUTCH

Clutch Control		Hydraulic
Clutch Pedal	Type	Suspended
	Pedal ratio	6.9
	Full stroke	155
	Height	250

---

## CONSUMER ASSISTANCE

Toll Free Assistance .....	9-2
Emergency Roadside Assistance .....	9-2
Trip Interruption .....	9-2
Registering Your Vehicle in a Foreign Country .....	9-3
Electrical Equipment .....	9-4
Installation of a Mobile Two-Way Radio System .....	9-4
Reporting Safety Defects .....	9-4

تلفن شبانه روزی: ۰۲۱-۸۸۸۶۲۰۸۵

[FarmaSOS.com](http://FarmaSOS.com)

# Consumer Assistance

---

Roadside Assistance is provided on all new 2006 model Kia Vehicles from the date the vehicle is delivered to the first retail buyer or otherwise put into use (in-service date), whichever is earlier, for a period of 60 months/60000 miles.

## ***Toll Free Assistance***

Kia's toll-free hot line is staffed 24 hours a day, 365 days a year, and is accessible from anywhere in the U.S. or Canada by dialing **1-800-333-4Kia**.

## ***Emergency Roadside Assistance***

Kia has set up a network of over 17,000 roadside assistance providers. Should you accidentally run out of fuel, require a battery jump, or need help changing a tire, a Kia Consumer Assistance Representative will dispatch (at no charge to you) someone to deliver a small quantity of gas, change a flat tire with your inflated spare, or arrange a battery jump to allow you to proceed to your destination. Kia also has a network of over 10,000 locksmiths to help you when you're locked out of your Kia, also at no charge.

In the event that mechanical difficulty renders your vehicle undriveable, Kia's Consumer Assistance Representative will arrange to transport your vehicle to the nearest Kia dealer or to an alternative service location.

Your vehicle must be accessible to our dispatch transport vehicle, as determined by our driver, to receive this service. In the event that Kia does not have a dealer or an alternative service location available in a particular location, Kia will work with a reputable local service facility to ensure that you receive prompt service. Warranty repairs are performed at no cost.

## ***Trip Interruption***

Trip interruption expense benefits are provided in the event that a warranty-related disablement occurs more than 150 miles from your home, and the repairs require more than 24 hours to complete. Reasonable reimbursement is included for meals, lodging, or rental car expenses. Trip interruption coverage is limited to \$100 per day subject to a three day maximum limit per incident, and you are required to contact the Kia Consumer Assistance Center to obtain pre-authorization of expenses. Once the Kia Consumer Assistance Center gives authorization for trip interruption benefits, they will assist you in making the necessary arrangements. Insurance deductibles, expenses, and claims paid by your insurance company or other providers are not eligible for reimbursement.

---

## **Registering Your Vehicle in a Foreign Country**

If you plan to register your vehicle in a foreign country, you should confirm that it conforms to the regulations in that country. Even if you successfully register the vehicle in a foreign country, you may experience the following problems and should therefore consider the possibility of having to deal with them:

1. The fuel specified for your vehicle may be unavailable. If other than the specified fuel is used, it could cause damage to the engine, the fuel injection system, and other fuel-related parts which may not be covered under your New Vehicle Emissions Limited Warranty.
2. We must, therefore, clearly state that when you leave the country in which you purchased your Kia as a new and register it in another country, problems arising from the use of fuel other than the specified fuel are not subject to manufacturer's warranty. Because vehicles like yours may not be marketed in the new country of registration, parts, servicing techniques and tools necessary to maintain and repair your vehicle may be unavailable.

Even if vehicles like yours are sold there, mechanical specifications required by the government may vary enough from the country of purchase to cause additional problems.

3. There may not be an Authorized Kia Dealer in the area in which you plan to register your vehicle. You may additionally experience difficulty in obtaining services in a foreign country for any number of reasons.

Further, we cannot assume any responsibility for problems that result from unsatisfactory service or lack of service outside of the United States.

FannaSOS.com

# Consumer Assistance

---

## **ELECTRICAL EQUIPMENT**

The electrical system of your vehicle is designed to perform under all reasonably expected operating conditions. However, before any additional electrical equipment is installed in your vehicle, consult an Authorized Kia Dealer, in order to ensure that you do not void your warranty.

Certain electrical equipment, or the way in which it is installed, may adversely affect the operation of your vehicle, including such systems as the engine control system, the audio system and the electrical charging system and thus potentially void all or part of your warranty.

We assume no responsibility for any expense you may incur or for any malfunction of your vehicle or any of its components or systems that may result from the installation of additional electrical equipment that is not supplied, or recommended for installation by, Kia.

## ***Installation of a Mobile Two-Way Radio System***

If a mobile two-way radio system is installed improperly, or if an excessively powerful type of system is used, other electronic systems may be adversely affected. To avoid damage to your vehicle, consult an Authorized Kia Dealer concerning the proper equipment and installation.

## **REPORTING SAFETY DEFECTS**

If you believe your vehicle has a defect which could cause an accident or could cause injury or death, you should inform the National Highway Traffic Safety Administration (NHTSA) immediately, in addition to notifying Kia Motors America, Inc.

If NHTSA receives similar complaints, it may open an investigation. A recall and remedy campaign may be ordered if a safety defect exists in a group of vehicles. However, NHTSA cannot become involved in individual problems between you, your dealer, or Kia Motors America, Inc.

---

To contact NHTSA, you may either call the Auto Safety Hotline toll-free at 1-800-424-9393 (or 366-0123 in Washington, D.C. area) or write to:

NHTSA

U.S. Department of Transportation

Washington, DC 20590

You can also obtain other information about motor vehicle safety from the Auto Safety Hotline.

All correspondence to Kia Motors America, Inc. concerning safety issues and defects should be forwarded to:

National Consumer Affairs Manager

Kia Motors America, Inc.

P.O. Box 52410

◆ Irvine, CA 92619-2410

امداد خودرو فارما

تلفن شبانه روزی: ۰۲۱-۸۸۸۶۲۰۸۵

FarmaSOS.com

## PURCHASING FACTORY AUTHORIZED MANUALS (U.S. ONLY)

The following publications covering the operation and servicing of your vehicle can be obtained from Helm Incorporated, either by filling out the attached form or for credit card holders, calling the toll-free phone number on the form. For manuals prior to the year shown below, contact Helm Incorporated, P.O. Box 07280, Detroit, Michigan 48207, or call 1-800-782-4356.

Publication Part Number	Form Description	Price Each*
UT050 PS 010	2005 Kia Optima Service Repair Manual	\$89.00
UT050 PS 011	2005 Kia Optima Electrical Troubleshooting Manual	\$49.00
UT050 PS 013	2005 Kia Optima Owner's Manual	\$20.00
KIA-R	Order Form for Previous Years- Indicate Year and Model Desired	FREE
*Prices are subject to change without notice and without incurring obligation.		

Valid only for sales within the U.S.. Canadian owners should contact their Authorized Kia Dealer.

**ORDER TOLL FREE: 1-800-782-4356**  
**(NOTE: For Credit Card Holder Orders Only)**  
**Monday-Friday 8:00 A.M. - 6:00 P.M. EST**  
**MINIMUM CREDIT CARD PURCHASE \$10.00**

**OR**

By completing this form you can order the materials desired. You can pay by check or money order, or charge to your credit card. Mail to Helm Incorporated at the address shown on the back of the order form.

2 0 0 5  K I A	Publication Part Number	VEHICLE Name	MODEL Year	QTY.	Price Each*	Total Price
* Prices are subject to change without notice and without incurring obligation.					TOTAL MATERIAL	
Orders are mailed within 10 days. Please allow adequate time for delivery.					Mich. Purchases Add 6% Sales Tax	
					HANDLING CHARGE	\$6.00
					TOTAL MATERIAL	



## INDEX

Index ..... 10-2

امداد خودرو فارما

تلفن شبانه روزی: ۰۲۱-۸۸۸۶۲۰۸۵

FarmaSOS.com

# Index

---

<b>A</b>		
Air Bag – Supplemental Restraint System ...	3-56	
Air Bag Warning Light .....	3-63	
Air Cleaner .....	7-35	
Air Conditioner (Specifications) .....	8-2	
Air Conditioning .....	4-66, 4-73	
Air Flow Control .....	4-71	
Alignment, Tire Balance and Wheel.....	7-48	
Aluminum Wheel Maintenance .....	7-66	
Antenna .....	3-90	
Anti-Lock Brake System.....	4-22	
Warning Light.....	4-43	
Anti-Theft Steering Column Lock, Ignition Switch and.....	4-2	
Ashtray		
Front.....	4-56	
Rear .....	4-57	
Automatic		
Door Locks .....	3-5	
Heating and Cooling Control System.....	4-68	
Transaxle .....	4-9, 7-30	
Transaxle (Specifications) .....	8-3	
Transaxle Fluid Level, Checking the .....	7-30	
<b>B</b>		
Balance, Wheel Alignment and Tire.....	7-48	
Battery.....	7-40	
Maintenance.....	7-41	
Recharging.....	7-42	
Belts, Safety .....	3-25	
Blade Replacement, Windshield Wiper.....	7-37	
Blades, Wiper.....	7-37	
Body Lubrication .....	7-34	
Brake/Clutch Fluid Level, Checking .....	7-26	
Brake		
♦ Parking.....	4-19, 7-27	
System .....	4-17	
System, Anti-Lock .....	4-22	
Wear Indicators, Disc .....	4-18	
And Clutch .....	7-26	
Brakes		
Power .....	4-17	
Break-In Process, Vehicle .....	1-3	
Bulb Replacement.....	7-53	
Bulbs, Light .....	8-3	
<b>C</b>		
Capacities (Specifications) .....	8-4	
Capacity, Oil.....	7-20	
Care		
of the Safety Belt System, Proper Use and....	3-42	
Exterior.....	7-63	
Interior .....	7-66	
Cargo Net.....	3-93	
Catalytic Converters,		

Operating Precautions for .....	5-4	Consumer Assistance .....	9-1
Center High-Mounted Stoplight		Coolant, Changing .....	7-23
Bulb Replacement.....	7-59	Coolant Level, Checking the .....	7-21
Chains		Cooling System, Engine .....	7-21
Tire .....	5-11	Cruise Control .....	4-26
Charging System Warning .....	4-40	Cup Holder.....	3-84
Check Engine (Malfunction Indicator) Light....	4-41		
Child		<b>Day/Night Rearview Mirror</b> .....	3-80
Restraint System, Placement of .....	3-46	Defroster	
Safety Lock, Rear Door.....	3-8	Rear Window.....	4-52
Children		Digital Clock .....	4-54
Restraint of Infants and Small.....	3-43	Dimensions .....	8-2
Restraint of Large .....	3-45	Disc Brake Wear Indicators.....	4-18
Cigarette Lighter .....	4-55	Dome Light.....	3-82
Cleaner, Air .....	7-35	Door	
Cleaning		Ajaz Warning .....	4-43
Interior Window Glass .....	7-67	Locks .....	3-5
Lap/Shoulder Belt Webbing .....	7-67	Locks, With the Key .....	3-5
Upholstery and Interior Trim.....	7-66	Locks, Without the Key .....	3-6
Clock, Digital .....	4-54	Downshifting .....	4-8
Cluster, Instrument .....	4-33, 4-34	Driving	
Clutch/Brake Fluid Level, Checking .....	7-26	At Night .....	5-9
Clutch		Conditions, Special .....	5-7
Brakes and.....	7-26	Conditions, Hazardous.....	5-7
Specifications .....	8-4	In Flooded Areas.....	5-12
Compartment, Engine.....	7-15	In the Rain.....	5-9
Console Storage Compartment .....	3-85		

# Index

---

Tips .....	5-1	Starting the .....	4-4
Your Vehicle.....	4-1	Exhaust Gas Precautions, Engine .....	5-3
Your Vehicle, Tips on.....	5-4	Exterior	
Winter.....	5-10	Care .....	7-63
		Overview, Interior and .....	2-2
<b>E</b> conomical Operation, Suggestions for.....	5-6		
Electrical Equipment .....	9-4	<b>F</b> an Speed Control Button.....	4-61
Electrical		Filler Lid, Fuel .....	3-73
Circuit Protection.....	6-7	Filter	
Power Outlet .....	3-86	Changing the Engine Oil and.....	7-17
System (Specifications) .....	8-4	Engine Oil and Oil.....	7-17
Electric Remote Control Mirror .....	3-78	Finish	
Emergency		Damage Repair.....	7-64
In Case of an .....	6-1	Maintenance.....	7-63
Roadside Assistance .....	9-2	Flasher, Hazard Warning .....	4-53, 6-2
Starting.....	6-4	Flat Tire, If You Have a.....	6-19
Emission Control System.....	5-3	Flooded Areas, Driving in .....	5-12
Engine		Fluids, Lubricants and.....	7-33
Compartment .....	7-15	Folding	
Cooling System.....	7-21	Rear Seat, Split.....	3-22
Exhaust Gas Precautions .....	5-3	Front	
Oil and Filter, Changing the .....	7-17	Ashtray .....	4-56
Oil and Oil Filter .....	7-17	Seat.....	3-12
Oil Level, Checking the .....	7-17	Seat Adjustment.....	3-13
Oil Pressure Warning .....	4-41	Fuel	
Specifications .....	8-4	Filler Lid .....	3-73

Gauge .....	4-36
Level Warning, Low .....	4-41
Requirements .....	5-2
Fuse Panel Description .....	6-10
Fuses .....	6-7
Fuses (Specifications) .....	8-3

<b>Gauges</b> .....	4-35
Glove Box .....	4-58

<b>Hazard Warning Flasher</b> .....	4-53,6-2
Hazardous Driving conditions .....	5-7
Headlight	
Aiming Adjustment .....	7-68
High Beam Indicator .....	4-42
Replacement .....	7-53
Headrest .....	3-21
Homelink® Wireless Control System .....	5-16
Hood .....	3-71
Horn .....	3-76
How To Use This Manual .....	1-1

<b>If You Have a Flat Tire</b> .....	6-19
Ignition Switch .....	4-2

And Anti-Theft Steering Column Lock .....	4-2
Illumination, Instrument Panel .....	4-37
Indicators, Warnings and .....	4-38
Infants and Small Children, Restraint of .....	3-43
Inflation Pressures (Tire) .....	7-44
Inspections, Necessary .....	5-5

Instrument	
◆ Cluster .....	4-33, 4-34
Panel Illumination .....	4-37
Panel Overview .....	2-3

Interior	
And Exterior Overview .....	2-2
Care .....	7-66
Features .....	4-54
Lights .....	3-82
Trim, Cleaning the Upholstery and .....	7-66
Window Glass, Cleaning the .....	7-67
Intermittent Wipers, Variable .....	4-49

<b>Jacking Instructions</b> .....	6-22
Jump Starting .....	6-4

<b>Keyless Entry System</b> .....	3-3
Key Reminder Warning Chime .....	4-42
Keys .....	3-2

# Index

---

Knowing Your Vehicle ..... 3-1

## Label

Information ..... 5-14

Tire Information ..... 5-16

Vehicle Certification ..... 5-14

## Lap/Shoulder Belt

Front and Rear Outboard ..... 3-38

Webbing, Cleaning the ..... 7-67

License Plate Light Bulb Replacement ..... 7-58

## Light

Bulbs (Specifications) ..... 8-3

Bulb Replacement Front Fog ..... 7-55

Bulb Replacement, Front Turn Signal ..... 7-55

Dome ..... 3-82

Interior ..... 3-82

Map ..... 3-82, 3-83

Lighter, Cigarette ..... 4-55

Lighting ..... 4-44

Control ..... 4-45

## Lights

Interior ..... 3-82

## Locks

Automatic Door ..... 3-5

Door ..... 3-5

Low Fuel Level Warning ..... 4-41

Low Brake Fluid Level Warning ..... 4-39

Lubricant Specifications ..... 7-60

Lubricants and Fluids ..... 7-33

Lubrication, Body ..... 7-34

Luggage Net ..... 3-93

Lumbar Support ..... 3-16

## Maintenance ..... 7-1

Aluminum Wheel ..... 7-66

Battery ..... 7-41

Bright Metal ..... 7-65

Finish ..... 7-63

Normal – Schedule 1 ..... 7-5

Owner ..... 7-11

Severe – Schedule 1 ..... 7-8

Service, Scheduled ..... 7-4

Services ..... 7-3

Underbody ..... 7-65

Malfunction Indicator ..... 4-41

## Manual

Climate Control System ..... 4-60

Transaxle ..... 4-6, 7-28

Transaxle (Specifications) ..... 8-3

Transaxle Oil Level, Checking the ..... 7-28

## Mirror

Day/Night Rearview ..... 3-80

Electric Remote Control ..... 3-78

Outside Rearview.....	3-78	Brake and Brake Fluid Warning .....	4-39
Vanity .....	4-59	Power	
Mirrors.....	3-78	Brakes .....	4-17
Modifications, Vehicle.....	5-3	Outlet, Electrical.....	3-86
		Steering.....	4-25, 7-27
		Steering Fluid Level, Checking the .....	7-27
		Windows.....	3-9
<b>N</b> ight, Driving at .....	5-9	Pregnant Women, Restraint of.....	3-43
		Proper Use and Care of	
		the Safety Belt System.....	3-42
<b>O</b> dometer .....	4-35		
<b>O</b> il		<b>R</b> ain, Driving in the.....	5-9
And Filter, Changing the Engine.....	7-18	Rear	
Capacity .....	7-20	Ashtray .....	4-57
Engine and Oil Filter .....	7-17	Center Belt 3 point .....	3-40
Filter, Engine Oil and .....	7-17	Door Child Safety Lock .....	3-8
Level, Checking the Engine .....	7-17	Lap/Shoulder Belt.....	3-38
Pressure Warning, Engine .....	4-41	Safety Belts .....	3-38
One-Touch Wipers .....	4-50	Seat .....	3-22
Outside Rearview Mirrors .....	3-78	Seat, Split Folding .....	3-22
Overheating.....	6-2	Window Defroster.....	4-52
Overloading.....	5-13	Rearview Mirrors	
Owner Maintenance.....	7-11	Day/Night.....	3-80
Precautions .....	7-13	Outside .....	3-78
		Recharging, Battery .....	7-42
<b>P</b> arking		Recliner, Adjusting the Front Seatback..	3-14, 3-18
Brake.....	4-19, 7-27		

# Index

---

Registering Your Vehicle in a Foreign Country ..9-3	Scheduled Maintenance Service .....7-4
Reminder Warning Chime, Key .....4-42	Seat
Remote	Adjustment, Front.....3-13, 3-16
Fuel Filler Lid Release .....3-74	Front .....3-13
Reporting Safety Defects .....9-4	Rear.....3-22
Restraint	Recliner.....3-14, 3-18
Of Infants and Small Children .....3-43	Slide .....3-13, 3-17
Of Large Children.....3-45	Shift, Recommended.....4-8
Of Pregnant Women.....3-43	Snow Tires .....5-10
System, Placement of a Child.....3-46	Spare Tire
System, Safety Belt.....3-29	Removing the .....6-20
Roadside Assistance, Emergency .....9-2	Special Driving Conditions .....5-7
Road Warning .....6-2	Specifications .....8-2
Rocking the Vehicle.....5-8	Lubricant.....7-60
Rotation, Tire.....7-46	Speedometer.....4-35
	Starting
	Emergency .....6-4
	Jump.....6-4
	The Engine .....4-4
<b>S</b> afety Belt	Steering
Restraint System.....3-29	Column Lock, Ignition Switch and Anti-Theft 4-2
System, Proper Use and Care of.....3-42	Power .....4-25, 7-27
Warning Light and Chime.....3-34	Wheel .....3-76
Front .....3-35	Tilt.....3-77
Rear.....3-38	Stoptlight Replacement,
Safety Lock, Rear Door Child .....3-8	Center High-Mounted .....7-59
Schedule 1-	Storage Compartment, Console .....3-85
Normal Maintenance .....7-5	
Severe Maintenance .....7-8	

Suggestions for Economical Operation.....	5-6	Toll-Free Assistance.....	9-2
Sunglass Holder.....	3-85	Towing.....	6-14
Sunroof.....	3-87	With a Vehicle Other Than a Tow Truck.....	6-15
Sunvisors.....	4-59	Traction Control System.....	4-30
Switch, Ignition.....	4-2	Trailer	
		Towing.....	5-13
<b>T</b> achometer.....	4-36	Transaxle	
Temperature		♦ Automatic.....	4-9, 7-30
Control Knob.....	4-63	Manual.....	4-6, 7-28
Gauge, Engine.....	4-35	Manual (Specifications).....	8-3
Theft-Alarm System.....	4-81	Oil Level, Check the Manual.....	7-28
Tilt Steering.....	3-77	Trip	
Tips on Driving Your Vehicle.....	5-4	Interruption.....	9-2
Tire		Meter.....	4-35
Balance, Wheel Alignment and.....	7-48	Trunk Lid.....	3-68
Chains.....	5-11	Turn Signal Light Bulb Replacement, Front ...	7-55
Quality Grading, Uniform.....	7-51	Turn Signals.....	4-47
Replacement.....	6-23, 7-47	Two-Way Radio System, Installation of a Mobile.....	9-4
Rotation.....	7-46		
Size Designation.....	7-50	<b>U</b> nderbody Maintenance.....	7-65
Speed Ratings.....	7-51	Uniform Tire Quality Grading.....	7-51
Tires		Upholstery and Interior Trim, Cleaning the ...	7-66
And Wheels.....	7-44		
Changing.....	6-22	<b>V</b> acuum Hose Routing Diagram, Vehicle	
Snow.....	5-10		
Specifications.....	8-3		

# Index

---

Emission Control Information and.....	5-15	Replacement.....	7-49
Vanity Mirror.....	4-59	Size Designation.....	7-50
Vehicle		Steering.....	3-76
At A Glance, Your.....	2-1	Wheels, Tires and.....	7-44
Break-In Process.....	1-3	Window Glass, Cleaning the Interior.....	7-67
Driving Your.....	4-1	Windows.....	3-9
Emission Control Information and		Power.....	3-9
Vacuum Hose Routing Diagram.....	5-15	Windshield	
Identification Number.....	5-14	Defrosting and Defogging.....	4-76
Knowing Your.....	3-1	Washers.....	4-51
Modifications.....	5-3	Wiper Blade Replacement.....	7-37
Rocking the.....	5-8	Wipers.....	4-49
		Winter Driving.....	5-10
<b>Warning</b>		Wiper, تلفن شیشه, تلفن ۰۲۱-۸۸۶۲۰۸۸	
And Indicators.....	4-38	Blade Replacement, Windshield.....	7-37
Road.....	6-2	Blades.....	7-37
Washer		Wipers	
Fluid Level, Checking the.....	7-33	And Washers.....	4-49
Wipers and.....	4-49	Variable Intermittent.....	4-49
Washers, Windshield.....	4-51	Wipers (continued)	
Washing.....	7-63	One-Touch.....	4-50
Waxing.....	7-64	Windshield.....	4-49
Weights (Specifications).....	8-2		
Wheel			
Alignment and Tire Balance.....	7-48		
Aluminum, Maintenance.....	7-66		
		<b>Your Vehicle At A Glance.....</b>	<b>2-1</b>