

KIA, THE COMPANY



Now that you are the owner of a Kia Vehicle, you'll probably be asked a lot of questions about your vehicle and the company like "What is a Kia?," "Who is Kia?," "What does 'Kia' mean?"

Here are some answers. First, Kia is the oldest car company in Korea. It's a company that has thousands of employees focused on building high-quality vehicles at affordable prices.

The first syllable, **Ki**, in the word "Kia" means "to arise from to the world" or "to come up out of to the world." The second syllable, **a**, means "Asia." So, the word **Kia**, means "to arise from" or "to come up out of Asia to the world."

FOREWORD

Thank you for choosing a Kia vehicle.

When you require service, remember that your dealer knows your vehicle best. Your dealer has factory-trained technicians, recommended special tools, genuine Kia replacement parts and is dedicated to your complete satisfaction.

Because subsequent owners require this important information as well, this publication should remain with the vehicle if it is sold.

This manual will familiarize you with operational, maintenance and safety information about your new vehicle. It is supplemented by a Warranty and Maintenance book that provides important information on all warranties regarding your vehicle. If your vehicle is equipped with an audio system, you will also have a Kia Integrated Audio System manual explaining its operation. We urge you to read these publications carefully and follow the recommendations to help assure enjoyable and safe operation of your new vehicle.

Kia offers a great variety of options, components and features for its various models.

Therefore, the equipment described in this manual, along with the various illustrations, may not all be applicable to your particular vehicle.

The information and specifications provided in this manual were accurate at the time of printing. Kia reserves the right to discontinue or change specifications or design at any time without notice and without incurring any obligation. If you have questions, always check with your Kia Dealer.

We assure you of our continuing interest in your motor-ing pleasure and satisfaction in your Kia vehicle.

© 2005 Kia Motors Corp.

All rights reserved. Reproduction by any means, electronic or mechanical, including photocopying, recording, or by any information storage and retrieval system or translation in whole or part is not permitted without written authorization from Kia Motors Corporation.

Printed in Korea

TABLE OF CONTENTS ■	Introduction	1
	Your vehicle at a glance	2
	Knowing your vehicle	3
	Driving your vehicle	4
	Driving tips	5
	In case of an emergency	6
	Maintenance	7
	Specifications	8
	Index	9

Introduction

1

How to use this manual / 1-2
Vehicle break-in process / 1-3

2

3

4

5

6

7

8

9

امداد خودرو فارما

تلفن شبانه روزی: ۰۲۱-۸۸۸۶۲۰۸۵

FarmaSOS.com

HOW TO USE THIS MANUAL

1

We want to help you get the greatest possible driving pleasure from your vehicle. Your Owner's Manual can assist you in many ways. We strongly recommend that you read the entire manual. Especially, in order to minimize the chance of death or injury, you must read the WARNING and CAUTION sections spread throughout the manual.

2

3

4

5

6

7

8

9

Illustrations complement the words in this manual to best explain how to enjoy your vehicle. By reading your manual, you learn about features, important safety information, and driving tips under various road conditions.

The general layout of the manual is provided in the Table of Contents. A good place to start is the index; it has an alphabetical listing of all information in your manual.

Sections: This manual has eight sections plus an index. Each section begins with a brief list of contents so you can tell at a glance if that section has the information you want.

You'll find various WARNING's, CAUTION's, and NOTICE's in this manual. These were prepared to enhance your personal safety. You should carefully read and follow ALL procedures and recommendations provided in these WARNING's, CAUTION's and NOTICE's.

WARNING

A **WARNING** indicates a situation in which serious bodily injury or death could result if the warning is ignored.

CAUTION

A **CAUTION** indicates a situation in which personal injury, perhaps severe, could result if the caution is ignored.

NOTICE

A **NOTICE** indicates a situation in which damage to your vehicle could result if the notice is ignored.

FarmaSOS.com

VEHICLE BREAK-IN PROCESS

No special break-in period is needed. By following a few simple precautions for the first 1,000 km (600 miles) you may add to the performance, economy and life of your vehicle.

- Do not race the engine.
- Do not maintain a single speed for long periods of time, either fast or slow. Varying engine speed is needed to properly break-in the engine.
- Avoid hard stops, except in emergencies, to allow the brakes to seat properly.
- Avoid full-throttle starts.

تلفن شبانه روزی: ۰۲۱-۸۸۸۶۲۰۸۵

FarmaSOS.com

1

2

3

4

5

6

7

8

9

	1
Your vehicle at a glance	2
Exterior overview / 2-2 Interior overview / 2-4 Instrument panel overview / 2-5	3
	4
	5
تلفن شبانه روزی: ۰۲۱-۸۸۸۶۲۰۸۵	6
	7
FarmaSOS.com	8
	9

EXTERIOR OVERVIEW

- 1
- 2
- 3
- 4
- 5
- 6
- 7
- 8
- 9



Your vehicle at a glance



1. Rear door child safety lock
2. Fuel filler lid
3. Rear window
4. Trunk (if equipped)
5. Spare tyre
6. Outside rearview mirror
7. Tail lights
8. Door handle
9. Antenna (if equipped)

1

2

3

4

5

6

7

8

9

RLDN0002

INTERIOR OVERVIEW

- 1
- 2
- 3
- 4
- 5
- 6
- 7
- 8
- 9



- 1. Door lock/unlock button
- 2. Outside rearview mirror control switch (if equipped)
- 3. Power window switches (if equipped)
- 4. Master power door lock control (if equipped)
- 5. Master power window control lock (if equipped)
- 6. Vent controls
- 7. Instrument cluster
- 8. Inside rearview mirror
- 9. Steering wheel
- 10. Steering wheel tilt (if equipped)
- 11. Trunk release button
- 12. Instrument panel illumination (if equipped)
- 13. Brake pedal
- 14. Fuel filler lid release lever

RLDA0004/1LDA2018

INSTRUMENT PANEL OVERVIEW



1. Driver's Air Bag (if equipped)
2. Light control / Turn signals
3. Instrument cluster
4. Wiper/Washer
5. Ignition switch
6. Seat warmer (if equipped)
7. Traction control system (if equipped)
8. Hazard
9. Climate control system
10. Shift lever
11. Passenger's airbag (if equipped)
12. Glove box
13. Audio controls (if equipped)
14. Hood release lever

- 1
- 2
- 3
- 4
- 5
- 6
- 7
- 8
- 9

RLDA0003

<p>فارسوس</p> <p>تلفون: ۰۲۱-۸۸۸۶۲۰۸۵</p> <p>FarmaSOS.com</p>	Keys / 3-2	1
	Remote keyless entry / 3-4	2
	Immobilizer system / 3-7	
	Door locks / 3-8	3
	Knowing your vehicle	
	Windows / 3-13	4
	Seats / 3-16	5
	Safety belts / 3-30	
	Airbags-supplemental restraint system / 3-56	6
	Trunk / 3-75	
Hood / 3-77	7	
Fuel filler lid / 3-79		
Mirrors / 3-82	8	
Interior lights / 3-86		
Storage compartment / 3-88	9	
Interior features / 3-91		
Sunroof / 3-96		
Luggage net / 3-99		
Antenna / 3-100		

KEYS

- 1
- 2
- 3
- 4
- 5
- 6
- 7
- 8
- 9



The key code number is stamped on the plate attached to the key set. Should you lose your keys, this number will enable an authorized Kia Dealer to duplicate the keys easily. Remove the plate and store it in a safe place. Also, record the code number and keep it in a safe and handy place, but not in the vehicle.



Key operations

- ① Master key
Used to start the engine, lock and unlock the doors, lock and unlock the glove box (if equipped), and open the trunk (if equipped).
- ② Transmitter (if equipped)
Used to lock and unlock the doors and trunk (if equipped).

⚠ WARNING - Ignition key
Leaving children unattended in a vehicle with the ignition key is dangerous even if the key is not in the ignition. Children copy adults and they could place the key in the ignition. The ignition key would enable children to operate power windows or other controls, or even make the vehicle move, which could result in serious bodily injury or even death. Never leave the keys in your vehicle with unsupervised children.

⚡ CAUTION

Use only Kia original parts for the ignition key in your vehicle. If an aftermarket key is used, the ignition switch may not return to ON after START. If this happens, the starter will continue to operate causing damage to the starter motor and possible fire due to excessive current in the wiring.

امداد خودرو فارسی

تلفن شبانه روزی: ۰۲۱-۸۸۸۶۲۰۸۵

FarmaSOS.com

1

2

3

4

5

6

7

8

9

REMOTE KEYLESS ENTRY (IF EQUIPPED)

- 1
- 2
- 3
- 4
- 5
- 6
- 7
- 8
- 9

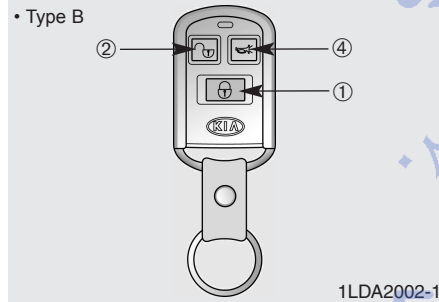
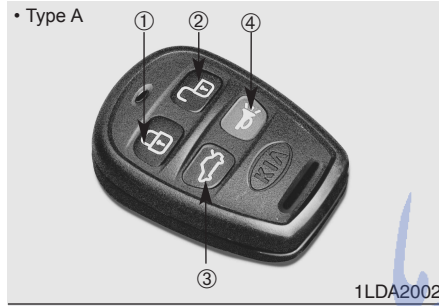

- ① Lock button
- ② Unlock button
- ③ Trunk lid open button
- ④ Panic button

- ① **Lock (🔒)**
All doors are locked if the lock button is pressed.
- ② **Unlock (🔓)**
All doors are unlocked if the unlock button is pressed.
After depressing this button, the doors will be locked automatically unless you open them within 30 seconds.
- ③ **Trunk lid open (🚪, if equipped)**
The trunk lid opens if this button is pressed.
- ④ **Panic (📢, if equipped)**
The horn sounds and hazard lamp will flash for about 27 seconds if this button is pressed.

تلفن شبانه روزی: ۰۲۱-۸۸۸۶۲۰۸۵

FarmaSOS.com

*** NOTICE**

The transmitter will not work if any of following occur:

- The ignition key is in ignition switch.
- You exceed the operating distance limit (10 m).
- The battery in the transmitter is weak.
- Other vehicles or objects may be blocking the signal.
- The weather is extremely cold.
- The transmitter is close to a radio transmitter such as a radio station or an airport which can interfere with normal operation of the transmitter.

When the transmitter does not work correctly, open and close the door with the ignition key. If you have a problem with the transmitter, contact an authorized Kia Dealer.

*** NOTICE**

Keep the transmitter away from water or any liquid. If the keyless entry system is inoperative due to exposure to water or liquids, it will not be covered by your manufacturer vehicle warranty.

Operational distance may vary depending upon the area the transmitter is used in. For example, if the vehicle is parked near police stations, government and public offices, broadcasting stations, military installations, airports, or transmitting towers, etc.

1

2

3

4

5

6

7

8

9

امداد خودرو فارسیا

تلفن شبانه روزی: ۰۲۱-۸۸۸۶۲۰۸۵

FarmaSOS.com

- 1
- 2
- 3**
- 4
- 5
- 6
- 7
- 8
- 9

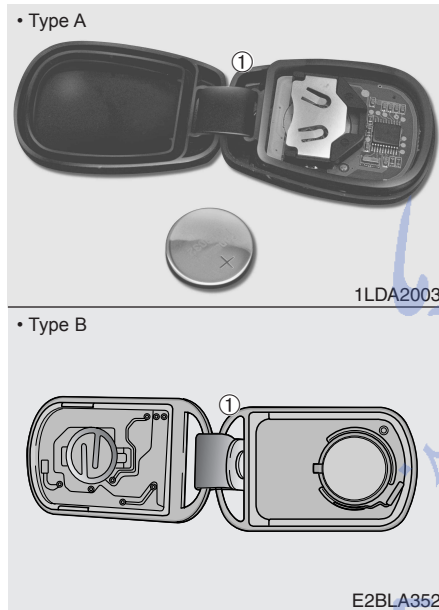

1. Insert a slim tool into the slot and gently pry open the transmitter centre cover (①).
2. Replace the battery with new one. When replacing the battery, make sure the battery positive “+” symbol faces up (type A) or faces down (type B) as indicated in the illustration.
3. Install the battery in the reverse order of removal.

*** NOTICE**

- Using the wrong battery can cause the transmitter to malfunction. Be sure to use the correct battery.
- To avoid damaging the transmitter, don't drop it, get it wet, or expose it to heat or sunlight.

*** NOTICE**

The keyless entry system transmitter is designed to give you years of troublefree use, however it can malfunction if exposed to moisture or static electricity. If you are unsure how to use your transmitter or replace the battery, contact an authorized Kia dealer.

Battery replacement

Transmitter uses a 3 volt lithium battery which will normally last for several years. When replacement is necessary, use the following procedure.

For replacement transmitters, see an Authorized Kia Dealer for reprogramming.

IMMOBILIZER SYSTEM (IF EQUIPPED)

Your vehicle is equipped with an electronic engine immobilizer system to reduce the risk of unauthorized vehicle use.

Your immobilizer system is comprised of a small transponder in the ignition key, and antenna coil in the key cylinder and BCM (Body Control Module) in the instrument panel.

With this system, whenever you insert your ignition key into the ignition switch and turn it to ON, the antenna coil in the ignition switch receives a signal from the transponder in the ignition key and then sends the signal to the BCM (Body control Module).

The BCM checks the signal whether the ignition key is valid.

If the key is determined to be valid, the engine will start.

If the key is determined to be invalid, the engine will not start.

To deactivate the immobilizer system:

Insert the ignition key into the key cylinder and turn it to the ON position.

To activate the immobilizer system:

Turn the ignition key to the OFF position. The immobilizer system activates automatically. Without a valid ignition key for your vehicle, the engine will not start.

* NOTICE

When starting the engine, do not use the key with other immobilizer keys around.

Otherwise the engine may not start or may stop soon after it starts. Keep each key separately not to have any malfunction after you receive your new vehicle.

CAUTION

The transponder in your ignition key is an important part of the immobilizer system. It is designed to give years of troublefree service, however you should avoid exposure to moisture, static electricity and rough handling. Immobilizer system malfunction could occur.

CAUTION

Do not change, alter or adjust the immobilizer system because it could cause the immobilizer system to malfunction and should only be serviced by an authorized Kia dealer. Malfunctions caused by improper alterations, adjustments or modifications to the immobilizer system are not covered by your vehicle manufacturer warranty.

1

2

3

4

5

6

7

8

9

DOOR LOCKS

- 1
- 2
- 3
- 4
- 5
- 6
- 7
- 8
- 9

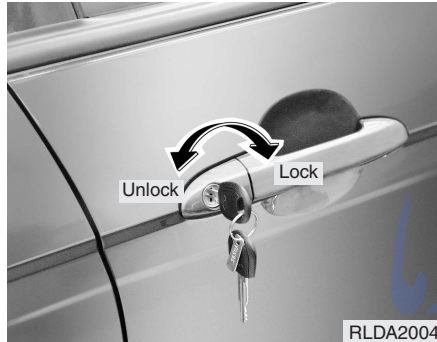

Operating door locks from outside the vehicle

- Turn the key toward rear of vehicle to unlock and toward front of vehicle to lock.
- Doors can also be locked and unlocked with the transmitter key.

- Once the doors are unlocked, it may be opened by pulling the door handle.
- When closing the door, push the door by the hand. Make sure that doors are closed securely.
- If you lock/unlock the front door with a key, all vehicle doors will lock/unlock automatically. (if equipped)

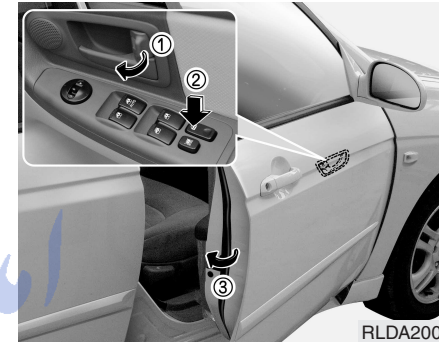

To lock a door without the key, push the inside door lock button (①) or door lock switch (②, if equipped) to the "LOCK" position and close the door (③).

* NOTICE

Always remove the ignition key, engage the parking brake, close all windows and lock all doors when leaving your vehicle unattended.

FarmaSOS.com

*** NOTICE**

If the door is locked/unlocked multiple times in rapid succession with either the vehicle key or door lock switch, the system may stop operating temporarily in order to protect the circuit and prevent damage to system components.

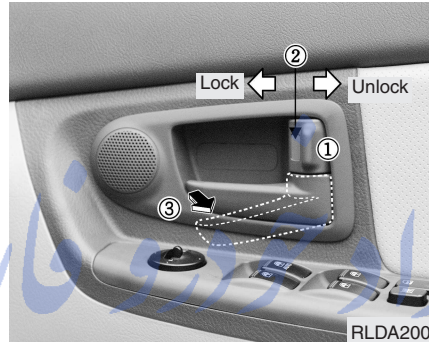

- Front doors cannot be locked if the ignition key is in the ignition switch and door is open.
- If you lock/unlock the front door with door lock button, all vehicle doors will lock/unlock automatically. (if equipped)

- 1
- 2
- 3
- 4
- 5
- 6
- 7
- 8
- 9

Operating door locks from inside the vehicle

With the door lock button

- To unlock a door, push the door lock button to the “UNLOCK” position.
- To lock a door, push the door lock button (①) to the “lock” position. If the door is locked, red part (②) of the knob becomes invisible.
- To open a door, pull the door handle (③) outward.

- 1
- 2
- 3
- 4
- 5
- 6
- 7
- 8
- 9



**With central door lock switch
(if equipped)**

The central door locking switch is located on the driver's arm rest. It is operated by depressing the door lock switch. If any door is open when the switch is depressed, the door will remain locked when closed.

- When pushing down on the front portion (①) of the driver's door lock switch, all vehicle doors will lock.
- When pushing down on the rear portion (②) of the switch, all vehicle doors will unlock.
- However, if the key is in the ignition switch and any front door is open, the doors will not lock when the front portion of central door lock switch is pressed.

CAUTION

- *The doors should always be fully closed and locked while the vehicle is in motion to prevent accidental opening of the door. Locked doors will also discourage potential intruders when the vehicle stops or slows.*
- *Be careful when opening doors and watch for vehicles, motorcycles, bicycles or pedestrians approaching the vehicle in the path of the door. Opening a door when something is approaching can cause damage or injury.*

FarmaSOS.com

⚠ WARNING

Leaving your vehicle unlocked can invite theft or possible harm to you or others from someone hiding in your vehicle while you are gone. Always remove the ignition key, engage the parking brake, close all windows and lock all doors when leaving your vehicle unattended.

⚠ WARNING - Unattended children

An enclosed vehicle can become extremely hot, causing death or severe injury to unattended children or animals who cannot escape the vehicle. Furthermore, children might operate features of the vehicle that could injure them, or they could encounter other harm, possibly from someone gaining entry to the vehicle. Never leave children or animals unattended in your vehicle.

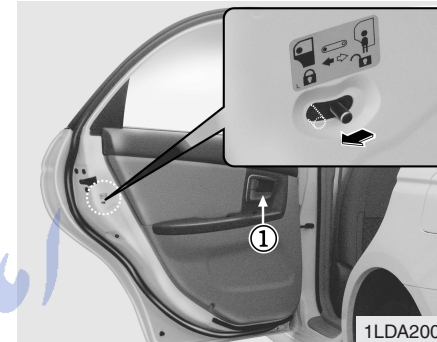

Rear door child safety lock

The child safety lock is provided to help prevent children from accidentally opening the rear doors from inside the vehicle. The rear door safety locks should be used whenever children are in the vehicle.

- 1
- 2
- 3
- 4
- 5
- 6
- 7
- 8
- 9

- 1
- 2
- 3
- 4
- 5
- 6
- 7
- 8
- 9

1. Open the rear door.
 2. Push the child safety lock located on the rear edge of the door to the “lock” position. When the child safety lock is in the “lock (⊕)” position, rear door will not open when the inner door handle is pulled inside the vehicle.
 3. Close the rear door.
 4. To open the rear door, pull the outside door handle.
- Even though the doors may be unlocked, the rear door will not open by pulling the inner door handle (①) until rear door child safety lock is unlocked (⊖).

⚠ WARNING - Rear door locks
If children accidentally open the rear doors while the vehicle is in motion, they could fall out and be severely injured or killed. To prevent children from opening the rear doors from the inside, the rear door safety locks should be used whenever children are in the vehicle.

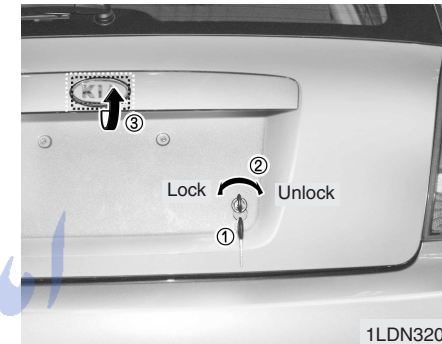

Rear hatch (if equipped)

Opening the rear hatch

- Rear hatch is locked or unlocked with a key.
- To open the rear hatch, insert the key into the lock (①) and turn it to the unlock position (②), pull up the rear hatch by pressing the handle (③).
- You can also lock/unlock the latch (but not release it) with the central door lock system (if equipped).
- If unlocked, the rear hatch can be opened by pressing the handle (③) and pulling the hatch up.

تلفن شبانه روزی: ۰۲۱-۸۸۸۶۲۰۸۵

FarmaSOS.com

WINDOWS

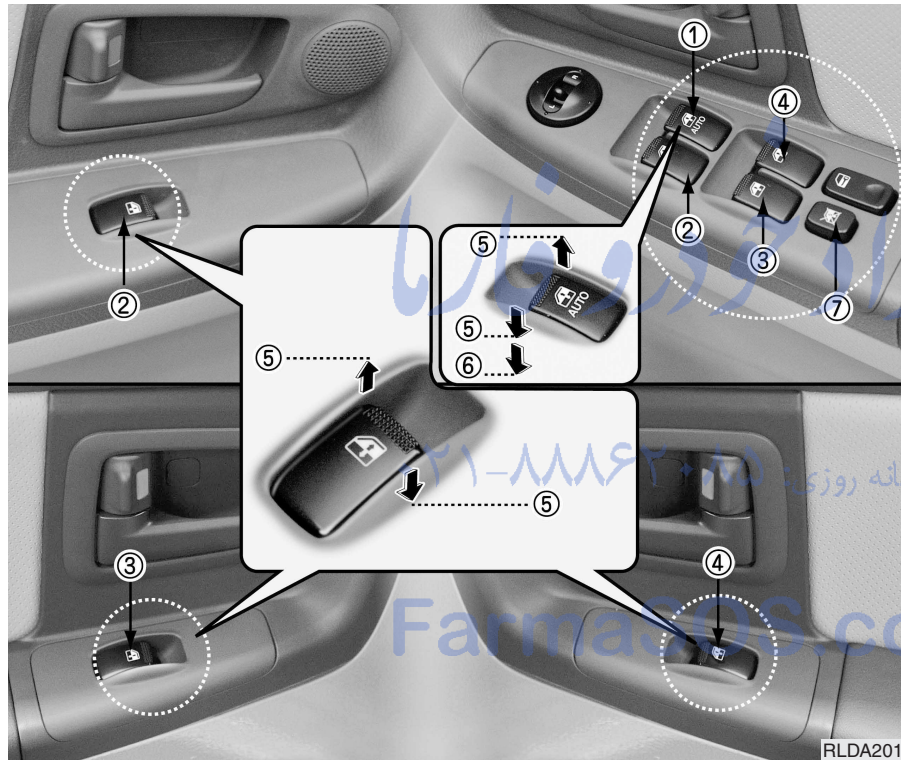

Power windows (if equipped)

- ① Driver's door power window switch
- ② Front passenger's door power window switch
- ③ Rear door (left) power window switch
- ④ Rear door (right) power window switch
- ⑤ Window opening and closing (see page 3-14)
- ⑥ Automatic power window down (Driver's window, see page 3-14)
- ⑦ Power window lock switch (see page 3-14)

• **Power window timer (if equipped)**

The power windows can be operated for approximately 30 seconds after the ignition key is removed or turned to the ACC or LOCK position. However, if the front doors are opened, the power windows cannot be operated even within the 30 seconds after the ignition key removal.

1
2
3
4
5
6
7
8
9

- 1
- 2
- 3**
- 4
- 5
- 6
- 7
- 8
- 9

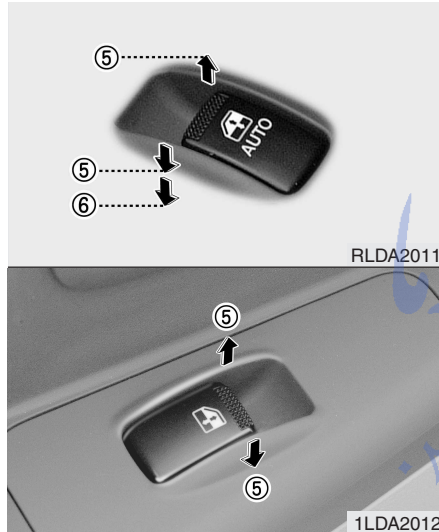

Window opening and closing

The driver's door has a master power window switch that controls all the windows in the vehicle. To open or close a window, press down (5) or pull up (5) the front portion of the corresponding switch.

Automatic power window down (driver's window, if equipped)

Depressing the power window switch momentarily to the second detent position (6) completely lowers the driver's window even when the switch is released. To stop the window at the desired position while the window is in operation, pull up the switch momentarily to the opposite direction of the window movement.

If the battery has been discharged or disconnected, the automatic power window system must be reset as follows:

1. Turn the ignition key to ON position.
2. Close each window and continue pulling up on each power window switch for at least 0.5 second after the window is completely closed.



Power window lock switch (if equipped)

- The driver can disable the power window switches on a passenger door by depressing the power window lock switch located on the driver's door to LOCK (pressed).
- When the power window lock switch is ON, the driver's master control cannot operate the passenger door power windows either.

Power windows (if equipped)

The ignition switch must be in the ON position for power windows to operate. Each door has a power window switch that controls that door's window. However, the driver has a power window lock switch which can block the operation of passenger windows. If you notice buffeting and pulsation (wind shock) with either side window open, you should open the opposite window slightly to reduce the condition.

*** NOTICE**

To prevent the power window system from the possibility of damage, do not open or close two windows at the same time. This will also ensure the longevity of the fuse.

CAUTION

- **Make sure heads and hands are safely out of the way before closing a window.**
- **Do not allow children to play with the power windows. Keep the driver's door power window lock switch in the LOCK position (depressed). Serious injury can result from unintentional window operation by the child.**
- **Do not extend face or arms outside through the window opening while driving.**
- **Always double check to make sure all arms, hands and other obstructions are safely out of the way before closing a window.**

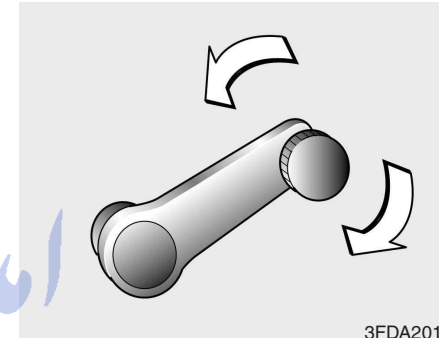

Manual windows (if equipped)

Use the window crank to open and close each window.

- 1
- 2
- 3
- 4
- 5
- 6
- 7
- 8
- 9

SEATS

1

2

3

4

5

6

7

8

9

Driver's seat

- ① Seat adjustment, forward / backward (see page 3- 18)
- ② Seatback recliner (see page 3- 19)
- ③ Seat adjustment, height* (see page 3- 18)
- ④ Seat heater switch*(see page 3- 20)
- ⑤ Headrest adjustment (see page 3- 21)

Front passenger seat

- ⑥ Seat adjustment, forward / backward (see page 3- 22)
- ⑦ Seatback recliner (see page 3- 23)
- ⑧ Seat heater switch*(see page 3- 24)
- ⑨ Headrest adjustment (see page 3- 25)

Rear seat

- ⑩ Split folding rear seat* (see page 3- 26)
- ⑪ Armrest* (see page 3- 29)
- ⑫ Headrest adjustment* (see page 3- 29)

* ; if equipped

RLDA2026

⚠ WARNING

- Loose objects in the driver's foot area could interfere with the operation of the foot pedals, possibly causing an accident. Loose objects might interfere with the seat slide mechanism. Do not place anything under the front seats.
- Children should never be left unattended in the car.

⚠ WARNING - Driver's seat

- Never attempt to adjust seat while the vehicle is moving. This could result in loss of control, and an accident causing death, serious injury, or property damage.
- Do not allow anything to interfere with the normal position of the seatback. Storing items against a seatback or in any other way interfering with proper locking of a seatback could result in serious or fatal injury in a sudden stop or collision.

(Continued)

(Continued)

- Always drive and ride with your seatback upright and the lap portion of the safety belt, or lap belt, snug and low across the hips. This position puts your safety belts in the best position to protect you in case of an accident.
- In order to avoid unnecessary airbag injuries including the possibility of severe injury or death, always sit as far back as possible from the steering wheel so that your chest is away at least 250 mm (10 inches) away from the steering wheel.

1

2

3

4

5

6

7

8

9

FarmaSOS.com

- 1
- 2
- 3
- 4
- 5
- 6
- 7
- 8
- 9

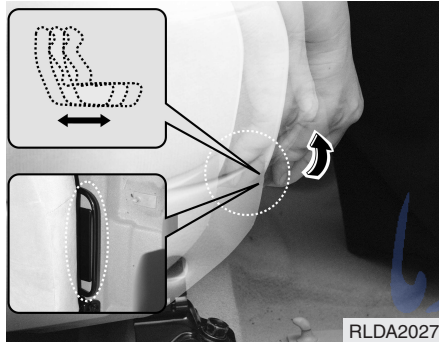

RLDA2027

Driver's seat adjustment

Adjusting the seat forward and backward

To move the seat forward or backward:

1. Pull the seat slide adjustment lever under the front edge of the seat cushion up and hold it.
2. Slide the seat to the position you desire.
3. Release the lever and make sure the seat is locked in place.

Adjust the seat before driving, and make sure the seat is locked securely by trying to move forward and backward without using the control knob. If the seat moves, it is not locked properly.

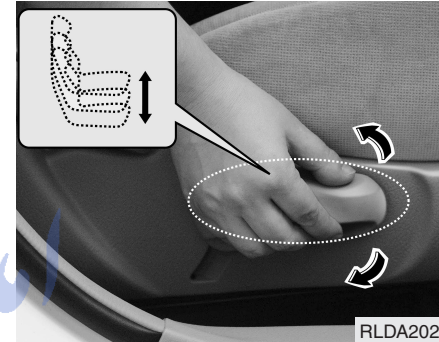

RLDA2028

Adjusting height of the driver's seat cushion (if equipped)

Pivot the lever upward to raise the seat cushion.

Pivot the lever downward to lower the seat cushion.

FarmaSOS.com

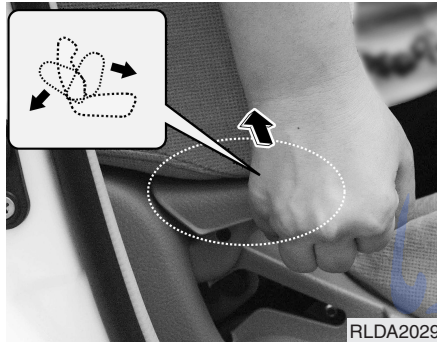

Adjusting the driver's seatback recliner

To recline the seatback:

1. Lean forward slightly and lift up on the seatback recline lever located on the outside of the seat, at the rear.
2. Carefully lean back on the seat and adjust the seatback of the seat to the position you desire.

3. Release the lever and make sure the seatback is locked in place. (The lever **MUST** return to its original position for the seatback to lock.)

⚠ WARNING

Driving or riding in a vehicle with a front seatback reclined could lead to serious or fatal injury in an accident. If a front seat is reclined during an accident, the occupant's hips may slide under the lap portion of the safety belt applying great force to the unprotected abdomen or neck. Serious or fatal internal injuries could result. Keep the seatbacks in a comfortably upright position whenever the vehicle is in motion.

- 1
- 2
- 3
- 4
- 5
- 6
- 7
- 8
- 9

دراد خودرو فارس

شبهانه روزی: ۰۸۵-۸۸۶۲۰۸۱

PharmaSOS.com

- 1
- 2
- 3
- 4
- 5
- 6
- 7
- 8
- 9



Warming the driver's seat (if equipped)

The front seats can be electrically heated individually when the ignition switch is ON. When you depress the seat warmer switch, a thermostat regulates seat temperature. To deactivate the heating system, depress the switch once again.

*** NOTICE**

- The seat warmer will not operate if ambient temperature is above 37 ± 3 °C (98.5 ± 5.5 °F).
- If the seat warmer doesn't work when the ambient temperature is below 28 ± 3 °C (82.5 ± 5.5 °F), have the system checked by an authorized dealer.
- When cleaning the seats, do not use an organic solvent such as thinner, benzene, alcohol and gasoline. Doing so may damage the surface of the heater or seats.
- To prevent overheating the seat warmer, do not place blankets, cushions or seat covers on the seats while the seat warmer is in operation.
- Do not place heavy or sharp objects on seats equipped with seat warmers. Damage to the seat warming components could occur.

⚠ WARNING

Passengers should use extreme caution when using seat warmers due to the possibility of excess heating or burns. In particular, the following types of passengers should exercise extreme care:

1. Infants, children, elderly or handicapped persons, or hospital outpatients
2. Persons with sensitive skin or those that burn easily
3. Fatigued individuals
4. Intoxicated individuals
5. Individuals taking medication that can cause drowsiness or sleepiness (sleeping pills, cold tablets, etc.)

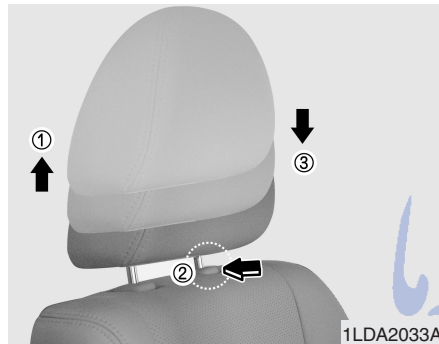

Headrest adjustment

Adjusting the height up and down

The headrest not only provides comfort for the driver and passengers, but also helps to protect the head and neck in the event of a collision.

To raise the headrest, pull it up to the desired position (1). To lower the headrest, push and hold the release button (2) on the headrest support and lower the headrest to the desired position (3). For best protection, adjust the headrest so its centre is as high as your ears. Also adjust the headrest so its distance from the head is as wide as your fist.

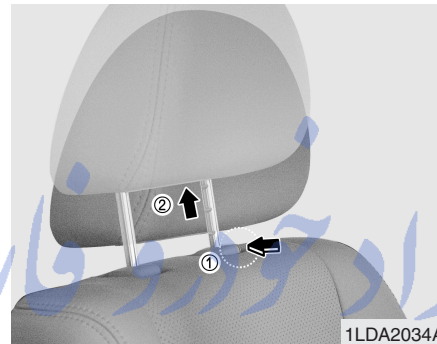

Removal

To remove the headrest, raise it as far as it can go then press the release lever (1) while pulling upward (2).

⚠ WARNING

To reduce the risk of head and neck injuries, do not drive the vehicle with the headrest removed or improperly positioned.

Do not adjust the driver's headrest while driving.

1

2

3

4

5

6

7

8

9

- 1
- 2
- 3
- 4
- 5
- 6
- 7
- 8
- 9

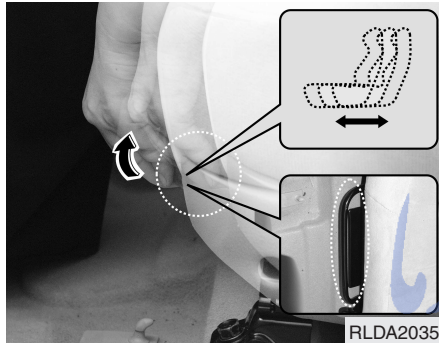

Adjusting the front passenger seat

Forward/backward position adjustment

To move the seat forward or backward:

1. Pull the seat slide adjustment lever (under the front edge of the seat cushion) up and hold it.
2. Slide the seat to the position you desire.
3. Release the lever and make sure the seat is locked in place.

Adjust the seat before driving, and make sure the seat is locked securely by trying to move forward and backward without using the control knob. If the seat moves, it is not locked properly.

⚠ WARNING

In order to avoid unnecessary airbag injuries including the possibility of severe injury or death, always sit as far back as possible by moving the seat far back, while still maintaining good vehicle control. Serious injury or death may be caused due to the deployment of the passenger's airbag.

تلفن شبانه روزی: ۰۲۱-۸۸۸۶۲۰۸۵

FarmaSOS.com



Adjusting the seatback recliner

To recline the seatback:

1. Lean forward slightly and lift up on the seatback recline lever located on the outside of the seat, at the rear.
2. Carefully lean back on the seat and adjust the seatback of the seat to the position you desire.

3. Release the lever and make sure the seatback is locked in place. (The lever **MUST** return to its original position for the seatback to lock.)

⚠ WARNING

Riding in a vehicle with a front seatback reclined could lead to serious or fatal injury in an accident. If a front seat is reclined, the occupant's hips may slide under the lap portion of the safety belt applying great force to the unprotected abdomen or neck. Serious or fatal internal injuries could result. Keep the seatbacks in a comfortably upright position whenever the vehicle is in motion.

- 1
- 2
- 3
- 4
- 5
- 6
- 7
- 8
- 9

FarmaSOS.com

تلفن شبانه روزی: ۰۸۵-۸۸۶۲-۸۱

- 1
- 2
- 3
- 4
- 5
- 6
- 7
- 8
- 9



Warming the front passenger seats (if equipped)

The front seats can be electrically heated individually when the ignition switch is ON.

When you depress the seat warmer switch, a thermostat regulates seat temperature. To deactivate the heating system, depress the switch once again.

*** NOTICE**

- The seat warmer will not operate if ambient temperature is above 37 ± 3 °C (98.5 ± 5.5 °F).
- If the seat warmer doesn't work when the ambient temperature is below 28 ± 3 °C (82.5 ± 5.5 °F), have the system checked by an authorized dealer.
- When cleaning the seats, do not use an organic solvent such as thinner, benzene, alcohol and gasoline. Doing so may damage the surface of the heater or seats.
- To prevent overheating the seat warmer, do not place blankets, cushions or seat covers on the seats while the seat warmer is in operation.
- Do not place heavy or sharp objects on seats equipped with seat warmers. Damage to the seat warming components could occur.

⚠ WARNING

Passengers should use extreme caution when using seat warmers due to the possibility of excess heating or burns. In particular, the following types of passengers should exercise extreme care:

1. Infants, children, elderly or handicapped persons, or hospital outpatients
2. Persons with sensitive skin or those that burn easily
3. Fatigued individuals
4. Intoxicated individuals
5. Individuals taking medication that can cause drowsiness or sleepiness (sleeping pills, cold tablets, etc.)

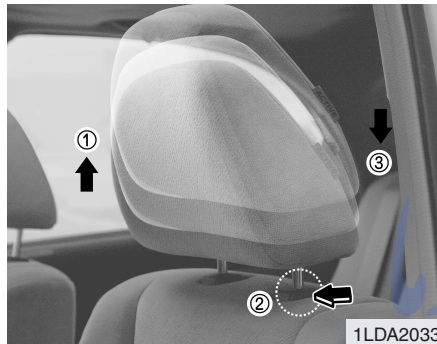

1LDA2033

Headrest adjustment

Adjusting the height up and down

The headrest not only provides comfort for the driver and passengers, but also helps to protect the head and neck in the event of a collision.

To raise the headrest, pull it up to the desired position (1). To lower the headrest, push and hold the release button (2) on the headrest support and lower the headrest to the desired position (3). For best protection, adjust the headrest so its centre is as high as your ears. Also adjust the headrest so its distance from the head is as wide as your fist.

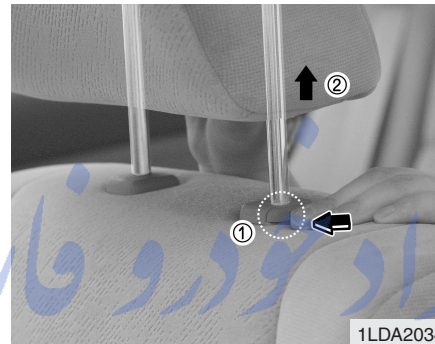

1LDA2034

Removal

To remove the headrest, raise it as far as it can go then press the release button (1) while pulling upward (2).

⚠ WARNING
To reduce the risk of head and neck injuries, do not drive the vehicle with the headrest removed or improperly positioned.

- 1
- 2
- 3
- 4
- 5
- 6
- 7
- 8
- 9

ParmaSOS.com

Rear seat

Split folding rear seat (if equipped)

The rear seatbacks fold forward to provide additional cargo space and to provide access to the cargo area.

- To fold the rear seatback(s) down, pull the lock release lever, then fold the seatback forward and down.
- To raise the seatback, lift and push it firmly until it clicks into place.
- When you return the seatback to its upright position, reposition the rear safety belts so that they can be used by rear seat passengers.

1

2

3

4

5

6

7

8

9

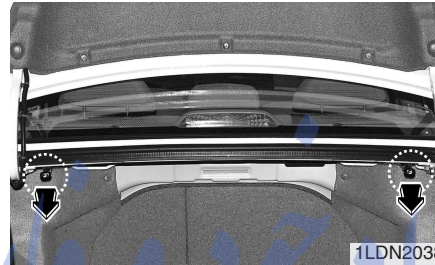

4 Door (if equipped)

1. Pull the lock release lever fold the seatback forward and down firmly.
2. Move the rear centre three-point seat belts (if equipped) to the outside (①) so that they don't interfere with the seatback when lowering.
3. Fold the seatback forward and down firmly (②).

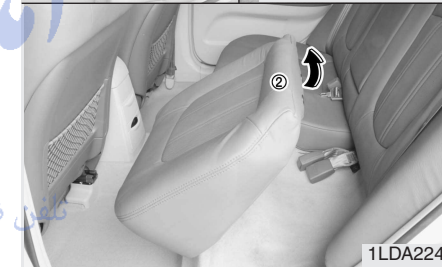
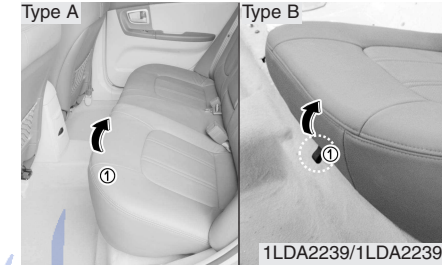

5 Door (if equipped)

1. Lift the front of seat cushion (①) up.
2. Lift the rear of seat cushion up (②).

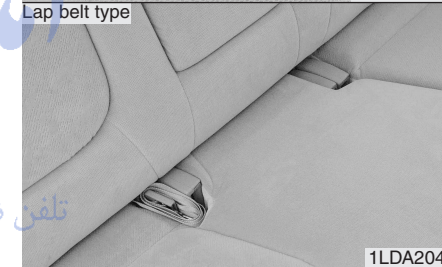
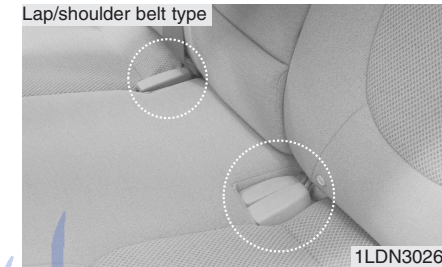
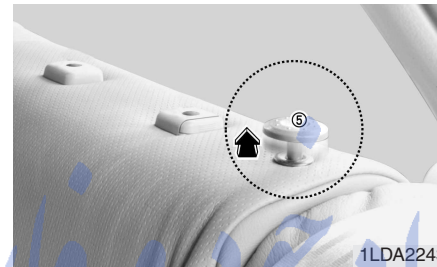

3. Move the seat cushion firmly until it clicks (③).
4. Remove the headrest and put the headrest poles into the holes on the rear of the seat cushion (④).

5. Pull the lock release lever (⑤).
6. Fold the seatback forward and down firmly (⑥).

*** NOTICE**

When you fold the rear seatback or put luggage on the rear seat cushion, insert the buckle in the pocket between the rear seatback and cushion. Doing so can prevent the buckle from being damaged by the rear seatback or luggage.



- 1
- 2
- 3**
- 4
- 5
- 6
- 7
- 8
- 9

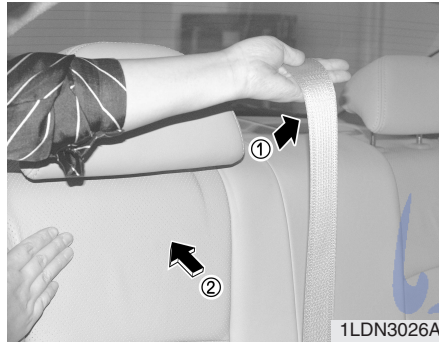

To unfold the rear seat:

1. Move the rear centre shoulder belt (①, if equipped) to the side so that it is clear of the seatback.
2. Lift and push the seatback backward firmly until it clicks into place (②).
Move and push the seat cushion downward firmly to the proper position (5 Door, if equipped).
3. Return the rear safety belt to the proper position.

CAUTION

- When returning the rear seatbacks to the upright position, remember to return the rear shoulder belts to their proper position.
- Do not remove the floor carpet in your vehicle. Emission control system components cause high exhaust temperatures under the floor.

WARNING - Cargo

Cargo should always be secured to prevent it from being thrown about the vehicle in a collision and causing injury to the vehicle occupants.

CAUTION

- Make sure the engine is off, the transaxle is in P and the parking brake is applied whenever loading or unloading cargo. Vehicle may move if shift lever is inadvertently moved to another position.
- Be careful when loading cargo through the rear passenger seats to prevent damage to the vehicle interior.
- When cargo is loaded through the rear passenger seats, ensure the cargo is properly secured to prevent it from moving while driving. Unsecured cargo in the passenger compartment can cause damage to the vehicle or injury to its occupants.



Armrest (if equipped)

The armrest is located in the centre of the rear seat. Pull the armrest down from the seatback. You will find a storage cover (if equipped).

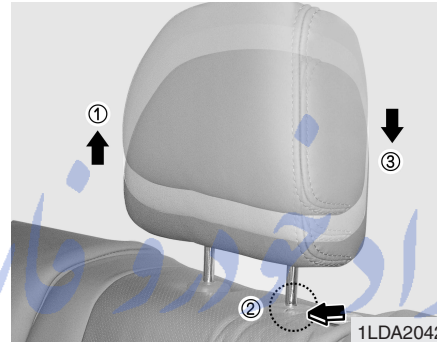

Headrest adjustment (if equipped)

Adjusting the height up and down
The headrest not only provides comfort for the driver and passengers, but also helps to protect the head and neck in the event of a collision.

To raise the headrest, pull it up to the desired position (1). To lower the headrest, push and hold the release button (2) on the headrest support and lower the headrest to the desired position (3). For best protection, adjust the headrest so its centre is as high as your ears. Also adjust the headrest so its distance from the head is as wide as your fist.

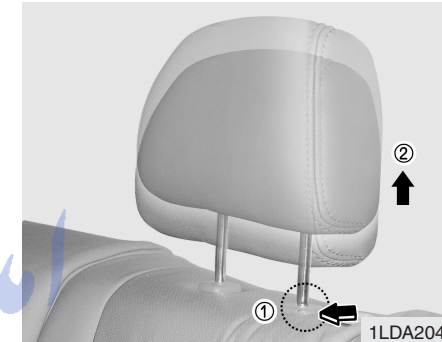

Removal

To remove the headrest, raise it as far as it can go then press the release lever (1) while pulling upward (2).

⚠ WARNING
To reduce the risk of head and neck injuries, do not drive the vehicle with the headrest removed or improperly positioned.

- 1
- 2
- 3
- 4
- 5
- 6
- 7
- 8
- 9

SAFETY BELTS

1

2

3

4

5

6

7

8

9

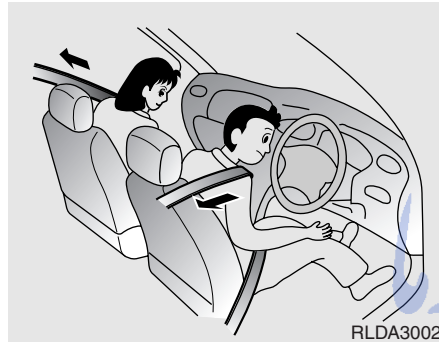

Pre-tensioner seat belt (if equipped)

Your vehicle is equipped with driver's and front passenger's pre-tensioner seat belts. The purpose of the pre-tensioner is to make sure that the seat belts fit tightly against the occupant's body in certain frontal collisions. The pre-tensioner seat belts will activate together with the airbags, where the frontal collision is severe enough.

CAUTION

The pre-tensioner seat belt is installed at the front seats, and the sensor is equipped inside the buckle, where presence of passenger is sensed by the fastening of the seat belts. Therefore, pre-tensioner will not activate if the passenger is not fastened with the seat belts. Likewise, it will activate if buckled even without a passenger in the seat. Pre-tensioner seat belt is designed to activate when the seatbelt is in use. To ensure the pretensioner seatbelts activate in event of a possible seatbelt buckle switch malfunction, the system is designed to activate regardless of whether a seat belt is in use or if no seat belt use is detected within 6 seconds of turning the ignition switch ON.

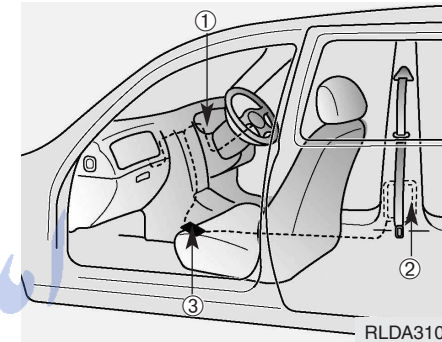

The seat belt pre-tensioner system consists mainly of the following components. Their locations are shown in the illustration.

- ① SRS airbag warning light
- ② Seatbelt pre-tensioner assembly
- ③ SRS airbag control module

⚠ WARNING

To obtain maximum benefit from a pre-tensioner seat belt:

- The seat belt must be worn correctly.
- The seat belt must be adjusted to the correct position.

⚠ CAUTION

When the pre-tensioner seat belts are activated, a loud noise may be heard and fine dust, which may appear to be smoke, may be visible in the passenger compartment and are not toxic.

Although, it is harmless, the fine dust may cause skin irritation and should not be breathed for prolonged periods. Wash your hands and face thoroughly after an accident in which the airbags and/or pre-tensioner seat belts were activated.

⚠ CAUTION

• *Because the sensor that activates the SRS airbag is connected with pre-tensioner seat belt, the SRS airbag warning light on the instrument panel will blink or illuminate for approximately 6 seconds after the ignition key has been turned to the "ON" position, then the light should go off.*

• *If the pre-tensioner seat belt is not working properly, this warning light will illuminate even if there is no malfunction of SRS airbag system. If the SRS airbag warning light does not illuminate when the ignition key is turned to "ON", or if it remains illuminated after blinking or illuminating for approximately 6 seconds, or if it illuminates while the vehicle is being driven, please have an authorized Kia dealer inspect the pre-tensioner seat belt or SRS airbag system as soon as possible.*

1

2

3

4

5

6

7

8

9

FarmaSOS.com

تلفن شبانه روزی: ۰۲۱-۸۸۸۶۲۰۸۵

1

CAUTION

The pre-tensioner seat belt assembly mechanisms become hot during activation. Do not touch the pre-tensioner seat belt assembly for several minutes after they have been activated.

2

3

4

5

6

7

8

9

WARNING

- Pre-tensioners are designed to operate once. After activation, pre-tensioner seat belts must be replaced. All seat belts, of any type, should always be replaced after they have been worn during a collision.
- Do not attempt to inspect or replace the pre-tensioner seat belts yourself. This must be done by an authorized Kia dealer.

WARNING

- Do not strike the pre-tensioner seat belt assemblies.
 - Do not attempt to service or repair the pre-tensioner seat belt system in any manner.
 - Improper handling of the pre-tensioner seat belt assemblies, and failure to heed the warnings not to strike, modify, inspect, place, service or repair the pre-tensioner seat belt assemblies may lead to improper operation or inadvertent activation causing serious injury.
- Always wear the seat belts when driving or riding in a motor vehicle.

Safety belt restraint system

WARNING - Safety belts

To minimize the risk of serious or fatal injury in an accident, the driver and all passengers should use the appropriate safety restraints for their age and size. The presence of airbags does not change the need to be properly restrained by a safety belt or size-appropriate child restraint. In fact, airbags are designed to work the best when passengers are correctly restrained in the vehicle. Be sure you are familiar with the information in this section, including the information on infant and child restraints. Read the safety warnings on the sun visors of your vehicle also.

We strongly recommend that the driver and all passengers be properly restrained at all times by using the safety belts provided with the vehicle. Proper use of the safety belts decreases the risk of severe injury or death in accidents or sudden stops.

All seats (including or except the centre rear seat) have lap/shoulder belts. Inertial locks in the safety belt retractors allow all of the lap/shoulder safety belts to remain unlocked during normal vehicle operation. This allows the occupants some freedom of movement and increased comfort while using the safety belts. If a force is applied to the vehicle, such as a strong stop, a sharp turn, or a collision, the safety belt retractors will automatically lock the safety belts.

Since the inertial locks do not require a collision in order to lock up, you may become aware of the safety belts locking while braking or going around sharp corners.

Always use the rear seat position(s) to install your child restraint(s).

Never install a child restraint system in the front passenger position, as an inflating airbag could cause serious or fatal injury to a child in that position.

Safety belts provide the best restraint when:

- The seatback is upright.
- The occupant is sitting upright (not slouched).
- The lap belt is snug across the hips.
- The shoulder belt is snug across the chest.
- The knees are straight forward.

To help you remember to fasten your safety belt, a warning light will come on and a chime will sound. See Safety Belt Warning Light and Chime on page 3-36.

1

2

3

4

5

6

7

8

9

تلفن شبانه روزی: ۰۸۵ + ۸۸۶۲ - ۱

FarmaSOS.com

1

2

3

4

5

6

7

8

9

⚠ WARNING - Australian design rules

- Seatbelts are designed to bear upon the bony structure of the body, and should be worn low across the front of the pelvis or the pelvis, chest and shoulders, as applicable; wearing the lap section of the belt across the abdominal area must be avoided.
- Seatbelts should be adjusted as firmly as possible, consistent with comfort, to provide the protection for which they have been designed. A slack belt will greatly reduce the protection afforded to the wearer.
- Care should be taken to avoid contamination of the webbing with polishes, oils and chemicals, and particularly battery acid. Cleaning may safely be carried out using mild soap and water.

(Continued)

(Continued)

- The belts should be replaced if webbing becomes frayed, contaminated or damaged.
- It is essential to replace the entire assembly after it has been worn in a severe impact even if damage to the assembly is not obvious.
- Belts should not be worn with straps twisted.
- Each belt assembly must only be used by one occupant; it is dangerous to put a belt around a child being carried on the occupant's lap.
- No modifications or additions should be made by the user which will either prevent the seat belt adjusting devices from operating to remove slack, or prevent the seat belt assembly from being adjusted to remove slack.

⚠ WARNING - After a collision

- Lap/shoulder belt assemblies may be stretched or damaged when subjected to the stress and forces of a collision.
- The entire restraint system should be inspected following any collision. All belts, retractors, anchors and hardware damaged by a collision should be replaced before the vehicle is operated again.

⚠ WARNING - Cargo area (if equipped)
 Passengers should never be allowed to ride in the cargo area of a vehicle. No safety belts are provided for the cargo area. Persons riding in the vehicle without a fastened safety belt are much more likely to suffer serious bodily injury or death during an accident.

⚠ WARNING - Twisted belts
 A twisted or jammed safety belt cannot restrain you properly. If you cannot untwist or unjam the safety belt, have an authorized Kia dealer fix it immediately. Never drive or ride with a twisted or jammed safety belt.

⚠ WARNING - Belt use
 Safety belts must be used correctly to work properly in an accident. Each seating position in your vehicle has a specific safety belt assembly that includes a buckle and tongue designed to be used together. For greatest effectiveness, follow these guidelines in using safety belts:

- Use the shoulder portion of the safety belt on the outside shoulder only. Never wear the shoulder portion under the arm.
- Never swing the safety belt around your neck to fit over the inside shoulder.
- Never wear the shoulder portion of the safety belt across the neck or face.

(Continued)

(Continued)

- Wear the lap portion as low as possible. Be sure that the lap belt fits snugly around the hips. Never wear lap belt or a lap portion of a lap/shoulder belt over your waist; it should always go over the stronger area of your hips.
- Never use a single safety belt for more than one person.
- The front seatbacks should always remain in a comfortable, upright position when the vehicle is moving.

- 1
- 2
- 3
- 4
- 5
- 6
- 7
- 8
- 9

1

2

3

4

5

6

7

8

9

⚠ WARNING - Safety belt care

- A damaged belt may not give you the protection you need in an accident.
- Inspect your safety belts periodically for excessive wear or damage. Pull out each belt fully and look for fraying, cuts, burns or other damage. Pull the safety belt out and let it retract a number of times. Make sure that the lap/shoulder belts return smoothly and easily into the retractor.
- Check the latches to make sure they latch and release without interference or delay.
- Never close the doors on any part of the lap or shoulder belt.
- Any belt not in good condition or in good working order should be promptly replaced.

⚠ CAUTION

Never close the doors on any part of the lap or shoulder belt. It can damage the safety belt or buckle which could increase the risk of injury in case of an accident.



Safety belt warning light and chime

As a reminder to the driver and passenger, safety belt warning light will blink for approximately 6 seconds each time you turn the ignition switch ON.

If the driver's lap/shoulder belt is not fastened when the key is turned ON, the safety belt warning chime sounds and the safety belt warning light blinks for approximately 6 seconds.



Lap/shoulder belt

To fasten the front lap/shoulder belt:

1. Grasp the buckle and tongue plate.
2. Slowly pull the lap/shoulder belt out from the retractor.

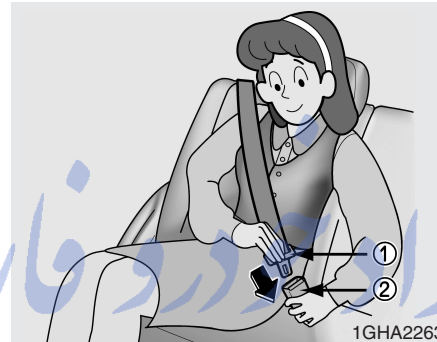

3. Insert the tongue plate (①) into the open end of the buckle (②) until an audible “click” is heard, indicating the belt is locked in the buckle.

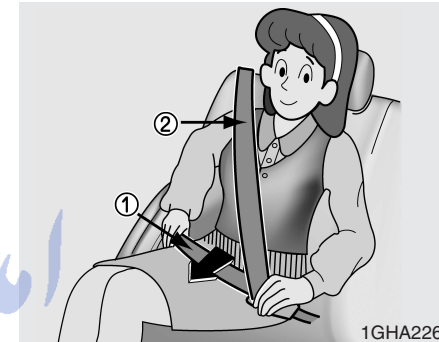

4. Position the lap portion (①) of the belt across your lap as **LOW ON THE HIPS** as possible to reduce the risk of sliding under it during an accident. Adjust the belt to a **SNUG FIT** by pulling up on the shoulder portion (②) of the safety belt. The belt retractor is designed to take up excess webbing automatically and to maintain tension on the belt. For your safety, do not put any excess slack into the safety belt at any location.

- 1
- 2
- 3
- 4
- 5
- 6
- 7
- 8
- 9

- 1
- 2
- 3
- 4
- 5
- 6
- 7
- 8
- 9

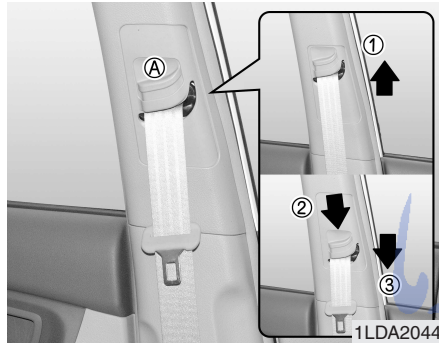

5. Adjust the shoulder anchor position to your size. To raise the anchor position, push the anchor up (①). To lower the anchor position, press (②) the button (A) and slide the anchor down (③). After adjustment, make sure the anchor is locked in position.

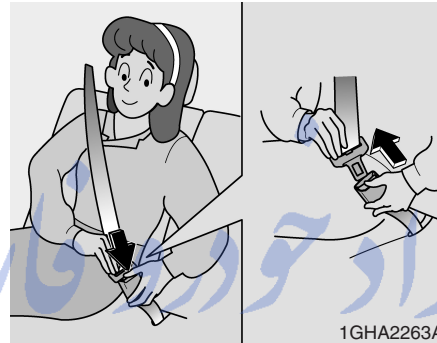

To unfasten the front lap/shoulder belt:

Press the release button on the buckle and allow the belt to slowly retract.

⚠ WARNING

- The seatbacks should always remain in a comfortable, upright position while the vehicle is in motion. The safety belt system will provide the most protection with the seatbacks in an upright position.
- Never wear the shoulder portion of the safety belt under the outside arm or behind the back.
- Never wear the shoulder portion of the safety belt across the neck or face.
- Wear the lap portion of the safety belt as low on the hips as possible. Be sure the lap belt fits snugly around the hips. Never wear the lap belt over your waist.

(Continued)

(Continued)

- Never drive or ride with a twisted or jammed safety belt. If you cannot untwist or unjam the safety belt, see the nearest Kia dealer immediately.
- Never use a single belt to restrain more than one person at a time.

Failure to follow these warnings will increase the risk and severity of injury in an accident.

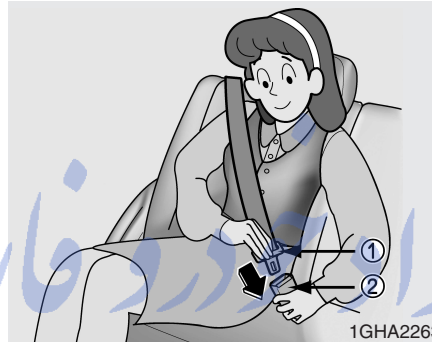

1GHA2263

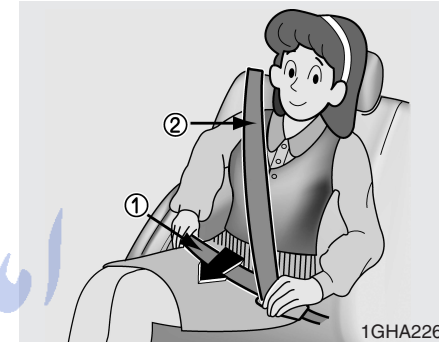

1GHA2264

Rear lap/shoulder belt

To fasten the rear lap/shoulder belt:

1. Grasp the buckle and tongue plate.
2. Slowly pull the lap/shoulder belt out.
3. Insert the tongue plate (1) into the open end of the buckle (2) until an audible “click” is heard, indicating the belt is locked in the buckle.

4. Position the lap portion (1) of the belt across your lap as LOW ON THE HIPS as possible to reduce the risk of sliding under it during an accident. Adjust the belt to a SNUG FIT by pulling up on the shoulder portion (2) of the safety belt. The belt retractor is designed to take up excess webbing automatically and to maintain tension on the belt. For your safety do not put any excess slack into the safety belt.

- 1
- 2
- 3
- 4
- 5
- 6
- 7
- 8
- 9

- 1
- 2
- 3
- 4
- 5
- 6
- 7
- 8
- 9

To unfasten:

Press the release button on the buckle and allow the belt to slowly retract.

⚠ WARNING

- Never wear the shoulder portion of the safety belt under the outside arm or behind the back.
- Never wear the shoulder portion of the safety belt across the neck or face.
- Wear the lap portion of the safety belt as low as possible. Be sure the lap belt fits snugly around the hips. Never wear the lap belt over your waist.

(Continued)

(Continued)

- Never drive or ride with a twisted or jammed safety belt. If you cannot untwist or unjam the safety belt, see the nearest Kia dealer immediately.
- Never use a single belt to restrain more than one person at a time.

Failure to follow these warnings will increase the risk and severity of injury in an accident.

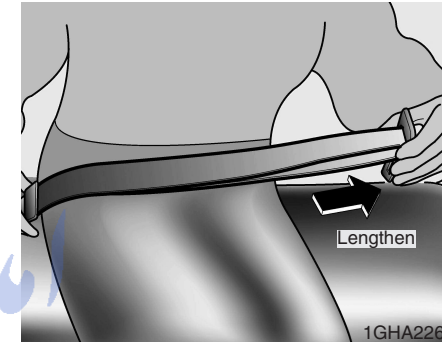

Lap belt (if equipped)

To fasten the lap belt:

1. Grasp the tongue and pull it low over the abdomen.

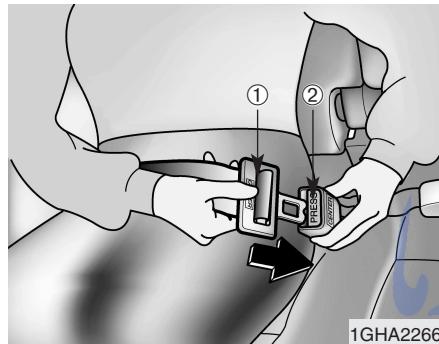

2. Insert the tongue plate (①) into the open end of the buckle (②) until an audible “click” is heard, indicating the latch is locked. Make sure the belt is not twisted.

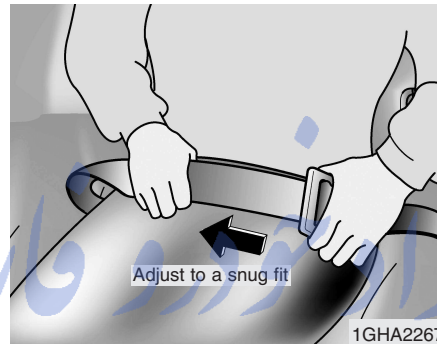

3. Grasp the free portion of the belt webbing and pull until the belt is snug over the hips and lower abdomen. If it becomes necessary to lengthen or shorten the belt, hold the latch plate tongue at right angles to the webbing and pull.

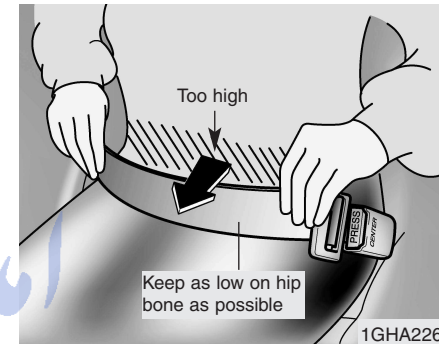

4. Make sure that the belt is placed as **LOW ON THE HIPS** as possible.

- 1
- 2
- 3
- 4
- 5
- 6
- 7
- 8
- 9

Knowing your vehicle

1

2

3

4

5

6

7

8

9

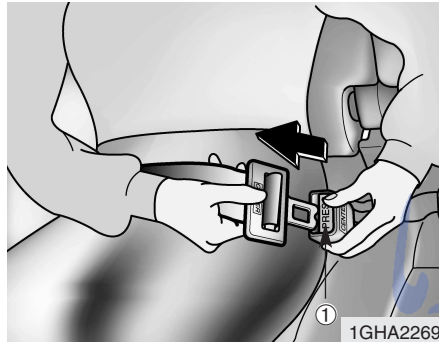

1GHA2269

To unfasten the lap belt:

Press the release button (1) on buckle.

⚠ WARNING - Lap belt

Be sure the lap belt is positioned snugly around the hips, and not on the waist. Failure to position the lap belt snugly around the hips will increase the chance and severity of injury in the event of a collision.

Lap/shoulder belt type

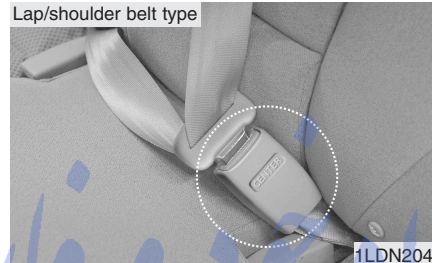

1LDN2045

Lap belt type

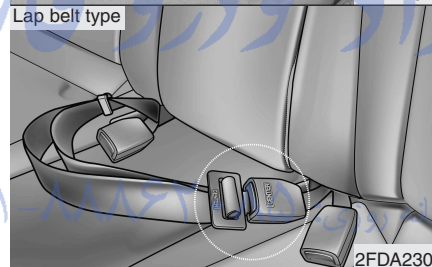

2FDA2307

When using the rear centre seat belt, the buckle with the "CENTRE" mark must be used.

Lap/shoulder belt type

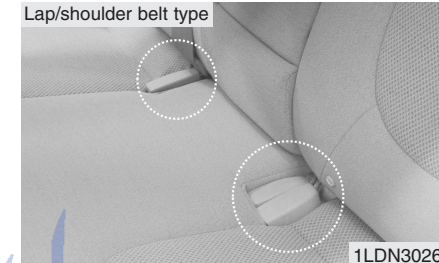

1LDN3026B

Lap belt type

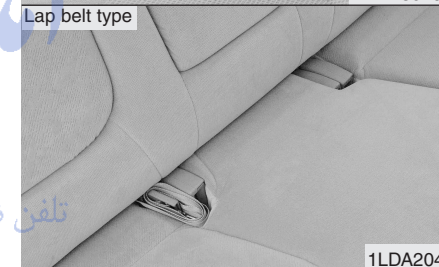

1LDA2046

Stowing the rear seat belt (if equipped)

- The rear seat belt buckles can be stowed in the pocket between the rear seatback and cushion when not in use.
- The centre seat belt can be stowed with the plate and webbing rolled in the pocket between the rear seatback and cushion.

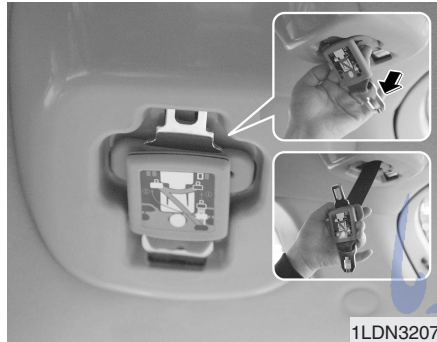

**3 Point rear centre belt
(if equipped)**

To fasten the rear centre belt

1. Extract the tongue plates from the holes on the belt assembly cover and slowly pull the tongue plates out from the retractor.

CAUTION - Cargo
Be sure that the cargo is securely loaded in the rear cargo area. Doing not so may damage the rear centre safety belt in sudden stop or certain collisions.

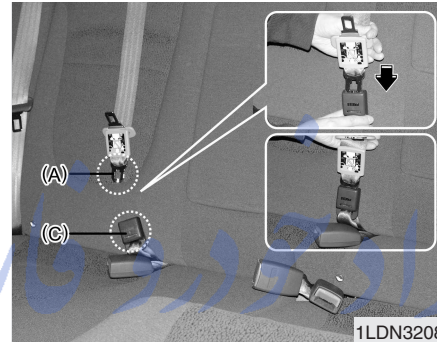

2. Insert the tongue plate (A) into the open end of the buckle (C) until an audible "click" is heard, indicating the latch is locked. Make sure the belt is not twisted.

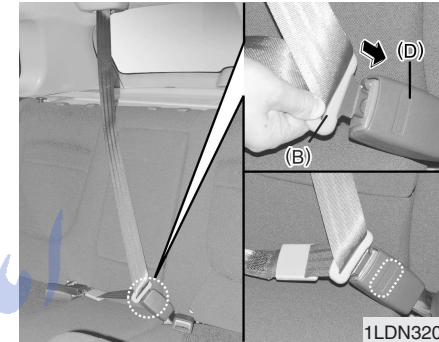

3. Pull the tongue plate (B) and insert the tongue plate (B) into the open end of the buckle (D) until an audible "click" is heard, indicating the latch is locked. Make sure the belt is not twisted.

- 1
- 2
- 3
- 4
- 5
- 6
- 7
- 8
- 9

FarmaSOS.com

Knowing your vehicle

1

2

3

4

5

6

7

8

9

There will be an audible “click” when the tab locks in the buckle. The seat belt automatically adjusts to the proper length only after the lap belt is adjusted manually so that it fits snugly around your hips, if you lean forward in a slow, easy motion, the belt will extend and let you move around. If there is a sudden stop or impact, the belt will lock into position. It will also lock if you try to lean forward too quickly.

⚠ WARNING

When using the rear seat centre belt, you must lock all tongue plates and buckles. If any tongue plate or buckle is not locked, it will increase the chance of injury in the event of collision.

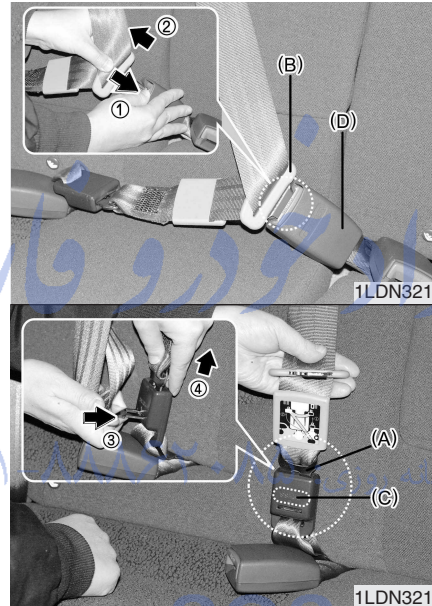

To unfasten the rear centre belt

1. Press the release button on the buckle (D) and remove the tongue plate (B) from the buckle (D).
2. Press the release button on the buckle (C) and remove the tongue plate (A) from the buckle (C)

The belt webbing will retract automatically.

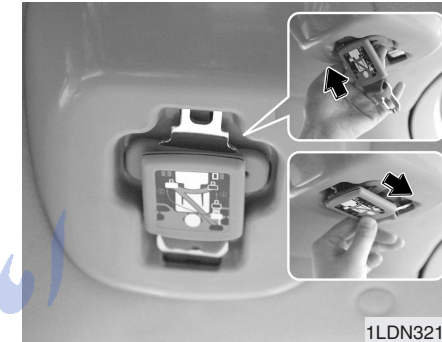

3. Insert the tongue plates into the holes and hang the tongue plates on the hooks on the belt assembly cover.

Proper use and care of the safety belt system

To ensure that the safety belts provide the maximum protection, please follow these instructions:

- Use the belts at all times - even on short trips.
- If the safety belt is twisted, straighten it prior to use.
- Keep sharp edges and damaging objects away from the belts.
- Periodically inspect belt webbing, anchors, buckles and all other parts for signs of wear and damage. Replace damaged, excessively worn or questionable parts immediately.

- To clean the belt webbing, use a mild soap solution recommended for cleaning upholstery or carpets. Follow the instructions provided with the soap.
- Do not make modifications or additions to the safety belt.
- After wearing a safety belt, make sure it fully retracts to the stowed position. Do not allow the belt to get caught in the door when you close it.

⚠ WARNING

Do not bleach or dye the webbing because this may weaken the webbing fibers and allow them to fail when loaded in a collision.

Restraint of pregnant women

Pregnant women should wear lap/shoulder belt assemblies whenever possible according to specific recommendations by their doctors. The lap portion of the belt should be worn **AS SNUGLY AND LOW AS POSSIBLE**.

⚠ WARNING - Pregnant women

Pregnant women must never place the lap portion of the safety belt over the area of the abdomen where the fetus is located or above the abdomen where the belt could crush the fetus during an impact.

1

2

3

4

5

6

7

8

9

Restraint of infants and small children

1

To increase their safety, infants and young children should always be restrained by a restraint system approved for their age and size.

2

Never allow a child to stand or kneel on the seat of a moving vehicle. Never allow a safety belt to be placed around both a child and an adult or around two children at the same time.

3

It is best for children to be seated in the rear seats.

5

6

7

8

9

⚠ WARNING - Children on laps

Never hold a child on your lap or in your arms in a moving vehicle.

Even a very strong person cannot hold onto a child in the event of even a minor collision.

⚠ CAUTION - Hot metal parts

Safety belts and seats can become hot in a vehicle that has been closed during warm/hot weather; they could burn a child. Check seat covers and buckles before you place a child anywhere near them.

Many companies manufacture child restraint systems (often called child seats) for infants and small children. An acceptable child restraint system must always satisfy the Safety Standards of your country. Make sure that any child-restraint system you use in your vehicle is labelled as complying with those safety standards.

The child-restraint system should be chosen to fit both the size of the child and the size of the vehicle seat. Be sure to follow any instructions provided by the child-restraint system manufacturer when installing the child-restraint system.

Restraint of larger children

As children grow, they may need to use new child-restraint systems, including larger child seats or booster seats, which are appropriate for their increased size.

A child who has outgrown available child-restraint systems should use the belts provided in the vehicle. When seated in the rear outboard seats, the child should be restrained by the lap/shoulder belt.

If the shoulder belt portion slightly touches the child's neck or face, try placing the child closer to the centre of the vehicle. If the shoulder belt still touches their face or neck they may need to be returned to a child restraint system. In addition, after-market devices are available from independent manufacturers which help pull the shoulder belt down and away from the child's face or neck.

⚠ WARNING - Shoulder belts on small children

- **Never allow a shoulder belt to be in contact with a child's neck or face while the vehicle is in motion.**
- **If safety belts are not properly worn and adjusted, there is a risk of death or serious injury to such a child.**

Child restraint system (if equipped)

For small children and babies, the use of a child seat or infant seat is strongly recommended. This child seat or infant seat should be of appropriate size for the child and should be installed in accordance with the manufacturer's instructions. It is further recommended that the seat be placed in the vehicle's rear seat since this can make an important contribution to safety.

Children riding in the car should sit on the rear seat and must always be properly restrained to minimize the risk of injury in an accident, sudden stop or sudden maneuver. According to accident statistics, children are safer when properly restrained in the rear seats than in the front seat. Larger children should use one of the seat belts provided.

1

2

3

4

5

6

7

8

9

شبانہ روزی: ۰۸۵ + ۸۸۶۲ - ۱
PharmaSOS.com

- 1
- 2
- 3
- 4
- 5
- 6
- 7
- 8
- 9

You are required by law to use safety restraints for children. If small children ride in your vehicle you must put them in a child restraint system (safety seat).

Children could be injured or killed in a crash if their restraints are not properly secured. For small children and babies, a child seat or infant seat must be used. Before buying a particular child restraint system, make sure it fits your car and seat belts, and fits your child. Follow all the instructions provided by the manufacturer when installing the child restraint system.



⚠ WARNING

- A child restraint system must be placed in the rear seat. Never install a child or infant seat on the front passenger's seat.

Should an accident occur and cause the passenger airbag to deploy, it could severely injure or kill an infant or child seated in an infant or child seat. Thus, only use a child restraint in the rear seat of your vehicle.

(Continued)

(Continued)

- Since a safety belt or child restraint system can become very hot if it is left in a closed vehicle, be sure to check the seat cover and buckles before placing a child there.
- When the child restraint system is not in use, store it in the trunk or fasten it with a safety belt so that it will not be thrown forward in the case of a sudden stop or an accident.
- Children who are too large to be in a child restraint should sit in the rear seat and be restrained with the available lap/shoulder belts. Never allow children to ride in the front passenger seat.

(Continued)

(Continued)

- Always make sure that the shoulder belt portion of the outboard lap/shoulder belt is positioned midway over the shoulder, never across the neck or behind the back. Moving the child closer to the centre of the vehicle may help provide a good shoulder belt fit. The lap belt portion of the lap/shoulder belt or the centre seat lap belt must always be positioned as low as possible on the child's hips and as snug as possible.
- If the seat belt will not properly fit the child, we recommend the use of an approved booster seat in the rear seat in order to raise the child's seating height so that the seat belt will properly fit the child.

(Continued)

(Continued)

- Never allow a child to stand up or kneel on the seat.
- Never use an infant carrier or child safety seat that "hooks" over a seatback; it may not provide adequate security in an accident.
- Never allow a child to be held in a person's arms while they are in a moving vehicle, as this could result in serious injury to the child in the event of an accident or a sudden stop. Holding a child in a moving vehicle does not provide the child with any means of protection during an accident, even if the person holding the child is wearing a seat belt.

Installation on the rear seats

⚠ WARNING

- Before installing the child restraint system, read the instructions supplied by the child restraint system manufacturer.
- Failure to observe this manual instructions regarding child restraint system and the instructions provided with the child restraint system could increase the chance and/or severity of injury in an accident.



armasOS.com

- 1
- 2
- 3
- 4
- 5
- 6
- 7
- 8
- 9

⚠ WARNING

- Do not install any child restraint system in the front passenger seat. Should an accident occur and cause the passenger airbag to deploy, it could severely injure or kill an infant or child seated in an infant or child seat. Therefore, only use a child restraint system in the rear seat of your vehicle.
- If the child restraint seat is not anchored properly, the risk of a child being seriously injured or killed in a collision greatly increases.

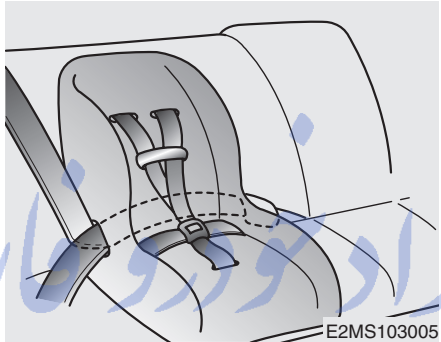

Installing a child restraint system by lap/shoulder belt (on the outboard rear seat)

To install a child restraint system on the outboard rear seats, do the following:

1. Place the child restraint system in the desired position.
2. Extend the shoulder/lap belt from its retractor.

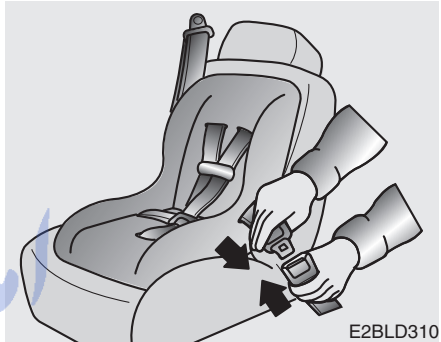

3. Route the lap/shoulder belt through the restraint according to the seat manufacturer's instructions.



4. Buckle the seat belt and allow the seat belt to take up any slack. After installation of the child restraint system, try to move it in all directions to be sure the child restraint system is securely installed.

If you need to tighten the belt, pull more webbing toward the retractor. When you unbuckle the seat belt and allow it to retract, the retractor will automatically revert back to its normal seated passenger emergency locking usage condition.



Installing a child restraint system by lap belt (on the centre rear seat) (if equipped) - Except Europe

To install a child restraint system on the centre rear seats, do the following:

1. Place the child restraint system on the centre rear seat.
2. Extend the latch plate tongue of the lap belt.

3. Route the lap belt through the restraint according to the seat manufacturer's instructions.
4. Buckle the seat belt and adjust the lap belt for a snug hold on the child restraint by pulling on the loose end of the belt. After installation of the child restraint system, try to move it in all directions to be sure the child restraint system is securely installed.

- 1
- 2
- 3
- 4
- 5
- 6
- 7
- 8
- 9

- 1
- 2
- 3
- 4
- 5
- 6
- 7
- 8
- 9

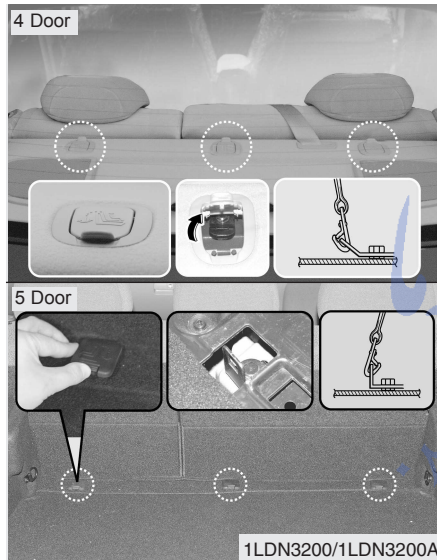

Securing a child restraint seat with “Tether Anchor” system (if equipped)

Child restraint hook holders are located on the shelf or floor behind the rear seats.

1. Open the tether anchor cover on the shelf or floor behind the rear seats.

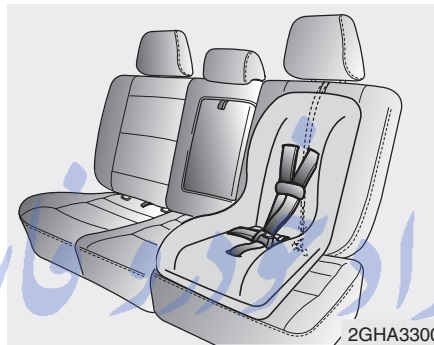

2. Route the child restraint seat strap over the seatback.

For vehicles with adjustable headrest, route the tether strap under the headrest and between the headrest posts, otherwise route the tether strap over the top of the seatback.

3. Connect the tether strap hook to the belonging child restraint hook holder and tighten to secure the seat.

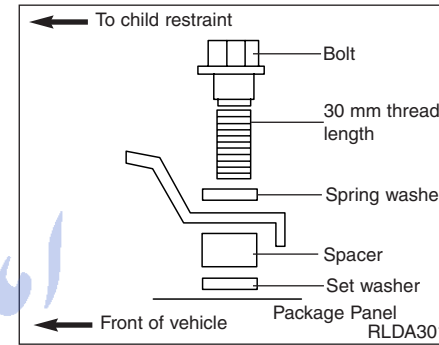

The anchor fitting package consists of:

4 Door

- Bolt: 5/16 inch - 18 unc
30 mm thread length
- Spring washer: 1.2mm thickness
- Spacer: 5 mm thickness
- Set washer: 0.7mm thickness
- Anchor fitting: Comforms to ADR 34/01

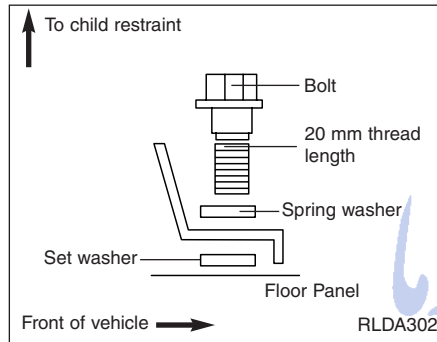

5 Door

- Bolt: 5/16 inch - 18 unc
20 mm thread length
- Spring washer: 1.2mm thickness
- Set washer: 0.7mm thickness
- Anchor fitting: Comforms to ADR 34/01

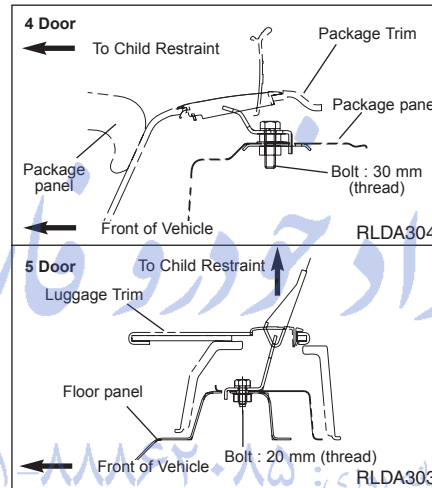

⚠ WARNING - Australian design rule

Child restraint anchorages are designed to withstand only those loads imposed by correctly fitted child restraints. Under no circumstances are they to be used for adult seat belts or harnesses or for attaching other items or equipment to the vehicle.

Securing a child restraint system with "ISOFIX" system and "Tether Anchorage" system (if equipped)

ISOFIX is a standardised method of fitting child seats that eliminates the need to use the standard adult seat belt to secure the seat in the vehicle. This enables a much more secure and positive location with the added benefit of easier and quicker installation.

An ISOFIX-seat can only be installed if it has vehicle-specific approval in accordance with the requirements of ECE-R44.

- 1
- 2
- 3
- 4
- 5
- 6
- 7
- 8
- 9

- 1
- 2
- 3
- 4
- 5
- 6
- 7
- 8
- 9

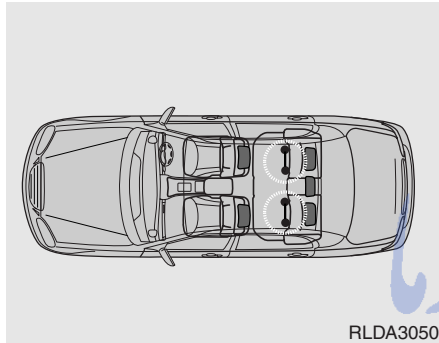

On each side of the rear seat, between the cushion and backrest, are located a pair of ISOFIX anchorage points together with a top tether mounting on the shelf behind the rear seats. During the installation, the seat has to be engaged at the anchorage-points in a way you can hear it clicking (check by pulling!) and has to be fixed with the Top Tether-belt on the belonging point on the shelf or floor behind rear seats.

The installing and the use of a child-seat has to be done according to the installing-manual, which is added to the ISOFIX-seat.

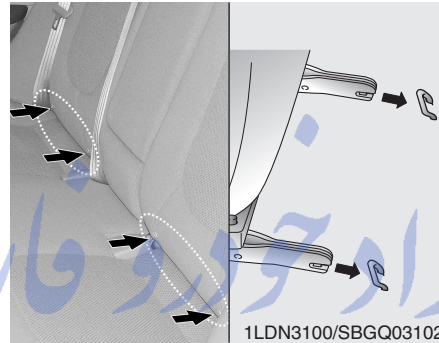

To secure the child restraint seat

1. To engage the child restraint seat to the ISOFIX anchor, insert the child restraint seat latch into the ISOFIX anchor. Listen for the audible “click” sound.
2. Connect the tether strap hook to the child restraint hook holder and tighten to secure the seat. Refer to “Securing a child restraint seat with the “Tether Anchorage” system” on page 3-52.

⚠ WARNING

- Do not install a child restraint seat at the centre of the rear seat using the vehicle's ISOFIX anchors. The ISOFIX anchors are only provided for the left and right outboard rear seating positions. Do not misuse the ISOFIX anchors by attempting to attach a child restraint seat in the middle of the rear seat to the ISOFIX anchors. In a crash, the child restraint seat ISOFIX attachments may not be strong enough to secure the child restraint seat properly in the centre of the rear seat and may break, causing serious injury or death.

(Continued)

(Continued)

- Do not mount more than one child restraint to a child restraint lower anchorage point. The improper increased load may cause the anchorage points or tether anchor to break, causing serious injury or death.
- Attach the ISOFIX or ISOFIX-compatible child restraint seat only to the appropriate locations shown in the illustration.
- Always follow the installation and use instructions provided by the manufacturer of the child restraint.

Child seat restraint suitability for seat position - For Europe

Use child safety seats that have been officially approved and are appropriate for your children. When using the child safety seats, refer to the following table.

Age group	Seating position (4 Door)			Seating position (5 Door)		
	Front passenger	Rear outboard	Rear centre	Front passenger	Rear outboard	Rear centre
0 : Up to 10 kg (0 - 9 months)	X	U	X	X	U	X
0+ : Up to 13 kg (0 - 2 years)	X	U	X	X	U	X
I : 9 kg to 18 kg (9 months - 4 years)	X	U, L1	X	X	U, L1	X
II & III : 15 kg to 36 kg (4 - 12 years)	X	U	X	X	U	X

X : Seat position not suitable for children in this mass group

U : Suitable for "universal" category restraints approved for use in this mass group

L1 : Suitable for "Römer ISOFIX GR1" approved for use in this age group (Approval No: E1 R44-03301133)



FarmasOS.com

AIRBAG - SUPPLEMENTAL RESTRAINT SYSTEM (IF EQUIPPED)

- 1
- 2
- 3
- 4
- 5
- 6
- 7
- 8
- 9

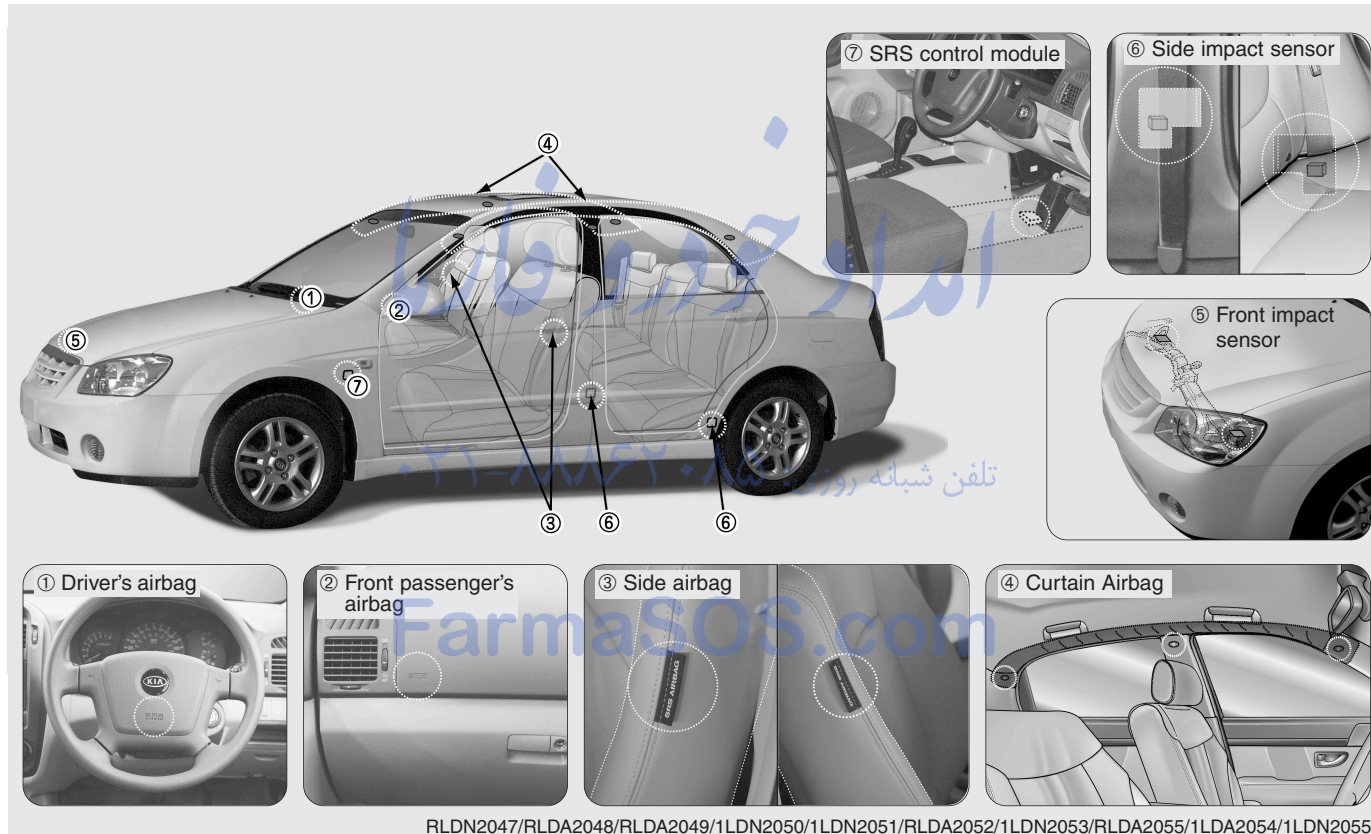

RLDN2047/RLDA2048/RLDA2049/1LDN2050/1LDN2051/RLDA2052/1LDN2053/RLDA2055/1LDA2054/1LDN2055A

- ① Driver's airbag (see page 3- 59)
- ② Front passenger's airbag (if equipped, see page 3- 60)
- ③ Side airbag (if equipped, see page 3- 62)
- ④ Curtain Airbag (if equipped, see page 3- 62)
- ⑤ Front impact sensor (if equipped, see page 3- 64)
- ⑥ Side impact sensor (if equipped, see page 3- 64)
- ⑦ SRS Control Module (see page 3- 64)
- Airbag inflation condition (see page 3- 65)
- Airbag non-inflation condition (see page 3- 67)
- Airbag warning light (see page 3- 72)
- Airbag service (see page 3- 72)
- Airbag warning label (see page 3- 74)

What your airbag system does

Driver's airbag and front passenger's airbag are designed to supplement the protection offered by the safety belt in certain frontal collisions. Likewise, side airbag and curtain airbags are designed to supplement the protection offered by the safety belt in side collisions. Safety belts are designed to reduce the injury of the driver or passengers in case of light impact or collision. However, to help reduce impact on driver or passengers in a serious collision, seat belts must also be correctly worn.

What your airbag system does not do

The air bag system is designed to supplement the protection offered by the safety belt system. IT IS NOT A SUBSTITUTE FOR THE SAFETY BELT.



تلفن شبانه روزی: ۰۲۱-۸۸۱۶۲۰۸۵
 FarmaSOS.com

The importance of using safety belts

1

There are four very important reasons to use safety belts even with an airbag supplemental restraint system. They:

2

- help keep you in the proper position (away from the airbag) when it inflates.

3

- reduce the risk of harm in rollover, side impact (vehicles not equipped with side and curtain airbags) or rear impact collisions, because an airbag is not designed to inflate in such situations and even a side curtain airbag is designed to inflate only in certain side impact collisions.

4

5

6

7

- reduce the risk of harm in frontal or side collisions which are not severe enough to actuate the airbag supplemental restraint system.

8

9

- reduce the risk of being thrown from your vehicle.

⚠ WARNING - Airbags & safety belts

- **Even in vehicles with air bags, you and your passengers must always wear the safety belts provided in order to minimize the risk and severity of injury in the event of a collision or rollover.**
- **Always wear your safety belt. It can help keep you away from the air bags during heavy braking just before a collision.**
- **If occupants are not fastened or correctly seated, they cannot be protected, and thus face serious injury or death.**

(Continued)

(Continued)

- **Driver's and front passenger's airbag are designed to inflate only in certain frontal collisions, and side and curtain airbags (if equipped) are designed to inflate in certain side impacts. They will generally not provide protection in side impacts (vehicles not equipped with side and curtain airbags) or rear impacts, rollovers, less severe frontal collisions. They will not provide protection from later impacts in a multi-impact collision.**

(Continued)

(Continued)

- If your vehicle has been subjected to flood conditions (e.g. soaked carpeting/standing water on the floor of the vehicle, etc.) or if your vehicle has become flood damaged in any way, do not attempt to start the vehicle or put the key in the ignition before disconnecting the battery. This may cause airbag deployment, which could result in serious personal injury or death. If flooded conditions are subjected to your vehicle, before starting the vehicle, have the vehicle towed to an authorized Kia dealer for inspection and necessary repairs.

Airbag system components

The main components of your SRS are:

- To indicate that your vehicle is equipped with airbags, the corresponding airbag covers are marked with "SRS AIRBAG".
 - Driver's airbag (see page 3- 59)
 - Passenger's airbag (see page 3- 60)
 - Side airbag (see page 3- 62)
 - Curtain airbag (see page 3- 62)
- A diagnostic system that continually monitors the system operation.
- An indicator light to warn you of a possible problem with the system.
- Emergency power backup in case your car's electrical system is disconnected in a crash.

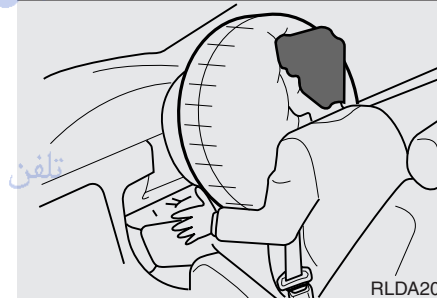

Driver's airbag (if equipped)

The driver's airbag is stored in the centre of the steering wheel.



FarmaSOS.com

- 1
- 2
- 3
- 4
- 5
- 6
- 7
- 8
- 9

⚠ WARNING

- You must always sit as far back from the steering wheel airbag as possible (chest at least 250 mm (10 inches) away from the steering wheel), while still maintaining a comfortable seating position for good vehicle control, in order to reduce the risk of injury or death in a collision.
- Never place objects over the airbag storage compartments or between the airbags and yourself. Due to the speed and force of the airbag inflation, such objects could hit your body at high speed and cause severe bodily injury and even death.
- Do not put stickers or ornaments on the steering wheel cover. These may interfere with the deployment of the airbag.

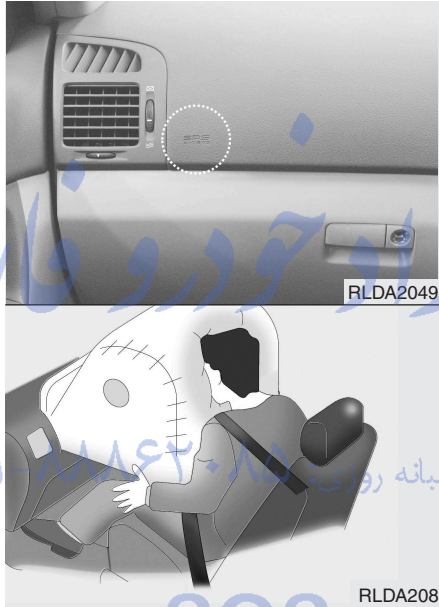

Front passenger's airbag (if equipped)

Front passenger's airbag is stored in the instrument panel on the glove box.

Since you cannot anticipate which airbags will deploy or from what direction, never put any objects or ornaments on the instrument panel.

⚠ WARNING

- The front seat passenger's airbag is much larger than the steering wheel airbag and inflates with considerably more force. It can seriously hurt or kill a passenger who is not in the proper position and wearing the safety belt properly. The front passengers should always move their seat as far back as practical and sit back in their seat.
- It is essential that the front passengers always wear their safety belts, even when the vehicle is moving in a parking lot or up a driveway into garage.

(Continued)

(Continued)

- If driver brakes the vehicle heavily in an urgent situations, occupants will be thrown forward. If front passengers are not wearing the safety belts, they will be directly in front of the storage compartment when inflation occurs. In that situation, serious injury or death is possible.
- Never allow front passenger to put their hands or feet on the instrument panel or put their face close to the instrument panel. The airbag will impact the front passenger when it inflates.

(Continued)

(Continued)

- Never allow children/old and feeble persons/pregnant women to sit on the front passenger's seat. Do not put child restraint system on the front passenger's seat either. They may be seriously injured by the airbag inflation when airbag deploys.
- Do not put objects or stickers on the instrument panel. Do not apply any accessory on the front windshield glass or do not install aftermarket mirrors or accessories on the factory installed rearview mirror. These may interfere with the deployment of airbag inflation or could hit your body at high speed and cause severe bodily injury and even death.

- 1
- 2
- 3
- 4
- 5
- 6
- 7
- 8
- 9

- 1
- 2
- 3
- 4
- 5
- 6
- 7
- 8
- 9

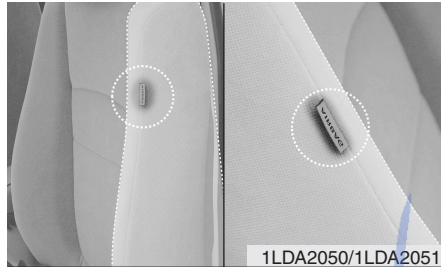

Side airbag (if equipped)

Side airbags are stored in the left side of the driver's seat and right side of the front passenger's seat.

If airbag inflation conditions are met (side collision), they will inflate.

⚠ WARNING

- Do not use any accessory seat covers for the vehicle equipped with side airbags. Use of seat covers could interfere with side airbag deployment.
- If seat or seat cover is damaged, have the vehicle checked and repaired by an authorized Kia dealer. Inform them that your vehicle is equipped with side airbags.
- Do not make modifications or additions to the seats. If seats not allowed by Kia Motors are used, unexpected injury may result in due to the malfunction of the airbag system.

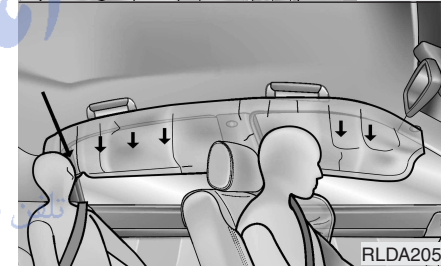
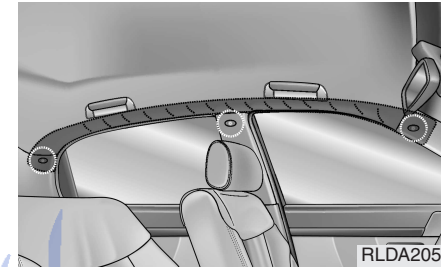

Curtain airbag (if equipped)

Curtain airbags are located along both sides of the roof rails above the front and rear doors.

They are designed to help protect the heads of the front seat occupants and the rear outboard seat occupants in certain side impact collisions.

- If the curtain airbag deploys, it remains inflated for approximately 3 seconds. The curtain airbag deployment occurs only on the side of the vehicle affected by the impact.
- The side airbags (side and/or curtain airbags) are not designed to deploy during collisions from the front or rear of the vehicle or in most rollover situations.
- The curtain airbags are designed to deploy only during certain side-impact collisions, depending on the crash severity, angle, speed and impact. The curtain airbags are not designed to deploy in all side impact situations.

⚠ WARNING

- **In order for side airbags (side and curtain airbags) to provide its best protection, both front seat occupants and both outboard rear occupants should sit in an upright position with the seat belts properly fastened. Especially, children should sit in a proper child restraint system.**
- **When children are seated in the rear outboard seats, they must be seated in the proper child restraint system. Make sure to put the child restraint system as far away from the door side as possible, and secure the child restraint system to be locked in position.**

(Continued)

(Continued)

- **Do not allow the passengers to lean their heads or bodies onto doors, put their arms on the doors, stretch their arms out of the window, or place objects between the doors and passengers when they are seated on the seats where side airbags are equipped.**
 - **Never try to open or repair any components of the side curtain airbag system. This should be done only by an authorized Kia dealer.**
- Failure to follow the above mentioned instructions can result in injury or death to the vehicle occupants in an accident.**

- 1
- 2
- 3
- 4
- 5
- 6
- 7
- 8
- 9

FarmaSO3.com

Why didn't my airbag go off in a collision?

1 *(Inflation and non-inflation conditions of the airbag)*

2 There are many types of accidents in which the airbag would not be expected to provide additional protection.

3 These include rear impacts, second or third collisions in multiple impact accidents, as well as low speed impacts. In other words, just because your vehicle is damaged and even if it is totally unusable, don't be surprised that the airbags did not inflate.



1LDN2058/RLDA2055/1LDN2053/1LDA2054/1LDN2055A

Airbag collision sensors

① SRS control module

② Front impact sensor (if equipped)

③ Side impact sensor (if equipped)

⚠ WARNING

- Do not hit or allow any objects to impact the locations where airbag or sensors are installed. This may cause unexpected airbag deployment, which could result in serious personal injury or death.
- If the installation location or angle of the sensors is altered in any way, the airbags may deploy when they should not or they may not deploy when they should, causing severe injury or death. Therefore, do not try to perform maintenance on or around the airbag sensors. Have the vehicle checked and repaired by the authorized Kia dealer.

(Continued)

(Continued)

- Problems may arise if the sensor installation angles are changed due to the deformation of front bumper, body or B, C pillar where side collision sensors are installed. Have the vehicle checked and repaired by the authorized Kia dealer.
- Your vehicle has been designed to absorb impact and deploy the airbag(s) in certain collisions. Installing aftermarket bumper guards or replacing a bumper with non-genuine parts may adversely affect your vehicles collision and airbag deployment performance.

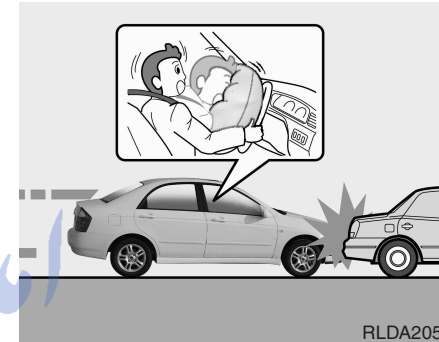

Airbag inflation condition

Front airbag

Front airbags (driver's and front passenger's airbags) are designed to inflate when the impact is delivered to front collision sensors depending on the intensity, speed or angles of impact of the front collision - generally from an area a little to the left to a little to the right of straight ahead.

- 1
- 2
- 3
- 4
- 5
- 6
- 7
- 8
- 9

Knowing your vehicle

1

2

3

4

5

6

7

8

9

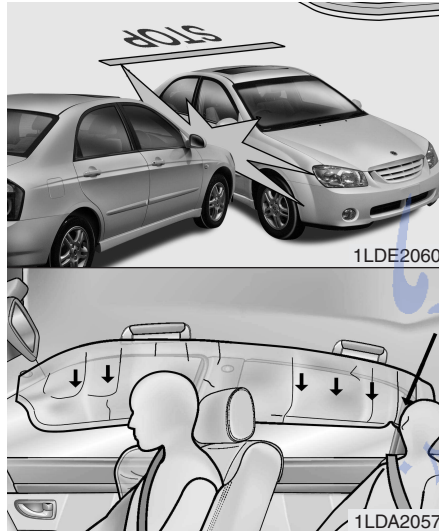

Although the front airbags (driver's and front passenger's airbags) are designed to inflate only in frontal collision, it may inflate in any collision if front impact sensors are delivered with certain impact.

Side airbags (side and/or curtain airbags) are designed to inflate only in side impact collision, it may inflate in any collision if side impact sensors are delivered with certain impact.

Side airbags (if equipped)

Side airbags (side and/or curtain airbags) are designed to inflate when the impact is delivered to side collision sensors depending on the strength, speed or angles of impact of side impact collision or rollover by the side impact.

In other words, they may inflate in accidents such as slant collision or impact, collision or impact where the front portion of the vehicle goes under a vehicle with a higher ground clearance (bus or truck), collision with a utility pole or rollover. Therefore, drive safely at all times.

If the vehicle chassis is impacted by bumps or objects on unimproved roads or sidewalks, airbags may deploy. Drive carefully on unimproved roads or on surfaces not designed for vehicle traffic.

To protect occupants, front airbags or pre-tensioner seat belts may deploy in certain side impact collisions.



Airbag non-inflation conditions

- In collisions, the vehicle safety belts are sufficient to protect the vehicle occupants and the airbags may not deploy. In some cases, deploying airbags in low-speed collisions can cause a secondary impact to the occupants (light abrasions, cuts, burns, etc.), or loss of vehicle control.

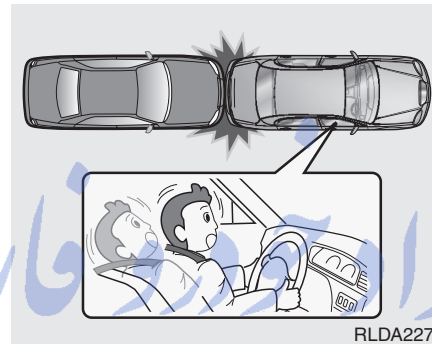

- Airbags may not inflate in rear collisions, because occupants are moved backward by the force of the impact. In this case, the airbags do not provide proper protection.



- Front airbags may not inflate in side impact collision, because occupants move to the direction of the collision, and thus front airbag deployment does not provide proper protection.

However, side or curtain airbags (if equipped) may inflate depending on the intensity, vehicle speed and angles of impact.

- 1
- 2
- 3
- 4
- 5
- 6
- 7
- 8
- 9

Knowing your vehicle

1

2

3

4

5

6

7

8

9

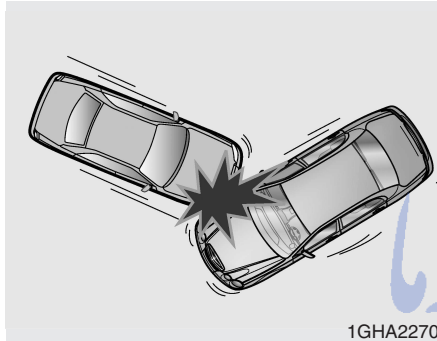

- In a slant impact or collision, the force delivered will be relatively weaker than that of frontal collision. So, the airbags may not inflate.



- At the moment of an accident, drivers brake heavily with reflex. In such heavy braking, the front portion of the vehicle is lowered by the force of the braking and the vehicle can go under a vehicle with a higher ground clearance. Airbags may not inflate in this situation because impacts may not be delivered or may be delivered with less intensity.

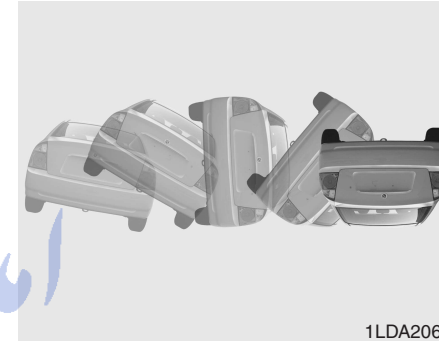

- Airbags may not inflate in rollover accidents because airbag deployment would not provide proper protection to the occupants. However, side airbags may inflate when the vehicle is rolled over by a side impact collision, if the vehicle is equipped with side airbags and/or curtain airbags.

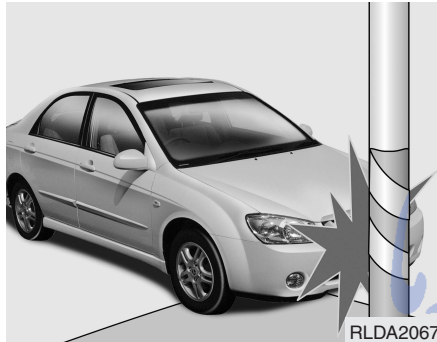

RLDA2067

How does the airbag system operate

- Airbag only operates when the ignition switch is turned to ON or START position.
- Airbags inflate instantly in the event of serious frontal or side collision (if equipped with side airbag or curtain airbag) in order to help protect the occupants from serious physical injury.
- There is no single speed at which the airbags will inflate. Generally, airbags are designed to inflate by the severity of a collision and its direction. These two factors determine whether the sensors send out an electronic deployment/inflation signal.
- Airbag deployment depends on a number of factors including vehicle speed, angles of impact and the density and stiffness of the vehicles or objects which your vehicle hits in the collision. Though, factors are not limited to those mentioned above.
- The front airbags will completely inflate and deflate in an instant. It is virtually impossible for you to see the airbags inflate during an accident. It is much more likely that you will simply see the deflated airbags hanging out of their storage compartments after the collision.

- 1
- 2
- 3
- 4
- 5
- 6
- 7
- 8
- 9

1

2

3

4

5

6

7

8

9

- In order to help provide protection in a severe collision, the airbags must inflate rapidly. The speed of airbag inflation reduces the likelihood of serious or life-threatening injuries and is thus a mandatory part of the airbag design.

However, airbag inflation can also cause injuries which normally can include facial abrasions, bruises and broken bones, because that speed also causes the airbags to expand with a great deal of force.

- **There are even circumstances under which contact with the steering wheel airbag can cause fatal injuries, especially if the occupant is positioned excessively close to the steering wheel.**

⚠ WARNING

- **Driver should sit as far back (at least 250 mm (10 inches) away) from the steering wheel airbag as possible to reduce the risk of injury or death in a collision. The front passenger should always move their seat as far back as possible and sit back in their seat.**
- **Airbag inflates instantly in an event of collision, passengers may be injured by the airbag expansion force if they are not in proper position.**
- **Airbag inflation may cause injuries which normally include facial or bodily abrasions, injuries by the broken glasses or burns by the explosives.**

Noise and smoke

When the airbags inflate, they make a loud noise and they leave smoke and powder in the air inside of the vehicle. This is normal and is a result of the ignition of the airbag inflator. After the airbag inflates, you may feel substantial discomfort in breathing due to the contact of your chest to both the safety belt and the airbag, as well as from breathing the smoke and powder. **We strongly urge you to open your doors and/or windows as soon as possible after impact in order to reduce discomfort and prevent prolonged exposure to the smoke and powder.**

Though smoke and powder are non-toxic, it may cause irritation to the skin (eyes, nose and throat etc). If this is the case, wash and rinse with the cold water immediately and consult the doctor if the symptom persists.

⚠ WARNING

When the airbags deploy, the airbag related parts in steering wheel and/or instrument panel and/or in both sides of the roof rails above the front and rear doors are very hot. To prevent injury, do not touch the airbag storage areas internal components immediately after an airbag has inflated.



Installing a child restraint on a front passenger seat is forbidden.

Never place a rear-facing child restraint in the front passenger seat. If the airbag deploys, it would impact the rear-facing child restraint, causing serious or fatal injury.

In addition, do not place front-facing child restraint in the front passenger seat either. If the front passenger airbag inflates, it would cause serious or fatal injuries to the improperly positioned or improperly restrained child.

⚠ WARNING

- **Extreme Hazard! Do not use a rearward facing child restraint on a seat protected by an airbag in front of it!**
 - **Never put child restraint in the front passenger seat. If the front passenger airbag inflates, it would cause serious or fatal injuries.**
 - **When children are seated in the rear outboard seats in which curtain airbags are equipped, be sure to put the child restraint system as far away from the door side as possible, and secure the child restraint system to be locked in position.**
- Inflation of side or curtain airbag (if equipped) could cause serious injury or death due to the expansion impact.**

- 1
- 2
- 3
- 4
- 5
- 6
- 7
- 8
- 9

- 1
- 2
- 3**
- 4
- 5
- 6
- 7
- 8
- 9



Airbag warning light

The purpose of airbag warning light in your instrument panel is to alert you of a potential problem with your airbag - Supplemental Restraint System (SRS).

When the ignition switch is turned ON, the indicator light should blink or illuminate for approximately 6 seconds, then go off.

Have the system checked if:

- The light does not turn on briefly when you turn the ignition ON.
- The light stays on after the engine starts.
- The light comes on while the vehicle is in motion.

Airbag (Supplemental Restraint System) service

Your Supplemental Restraint System is virtually maintenance-free. There are no parts which you can service.

You must have the system serviced under the following circumstances:

- If an airbag ever inflates, the airbag must be replaced. Do not try to remove or discard the airbag by yourself. This must be done by an authorized Kia dealer.
- If the airbag warning indicator light alerts you to a problem, have the airbag system checked as soon as possible. Otherwise, your airbag system may be ineffective.

FarmaSOS.com

CAUTION

Do not modify any part of the Supplemental Restraint System. Excessive modification could make the airbag system ineffective.

WARNING

- Do not modify your steering wheel, seat or any other part of the Supplemental Restraint System. Modification could make the system inoperable.
- Do not work on the system's components or wiring. This could cause the airbags to inflate inadvertently, possibly seriously injuring someone. Working on the system could also disable the system so that the airbags would not deploy in a collision.
- Any work on the SRS system, such as removing, installing, repairing, or any work on the steering wheel must be performed by a qualified Kia technician. Improper handling of the airbag system may result in serious personal injury.

When repairing or scrapping the vehicles

- Repairing steering wheel, instrument panel, centre console or roofs, or installing car audio around centre console or painting front metal sheet could disable the airbag system. Have them checked by an authorized Kia dealer.
- When leaving the vehicle at an authorized Kia dealer, inform that the vehicle is equipped with airbag system, and leave the owner's manual in the vehicle.
- Since airbag system contains explosive chemical substances, contact an authorized Kia dealer when scrapping the vehicle.

- 1
- 2
- 3
- 4
- 5
- 6
- 7
- 8
- 9

Knowing your vehicle

- 1
- 2
- 3**
- 4
- 5
- 6
- 7
- 8
- 9



Airbag warning label

Airbag warning label is attached to alert driver and passengers of potential risk of airbag system.

TRUNK (IF EQUIPPED)



Outside the vehicle

- To open the trunk, insert the key into the lock and turn it clockwise (①).
- To close the trunk, use both hands to push the trunk lid down. Check to see if the trunk is completely shut.
- Trunk can be opened with transmitter (if equipped).

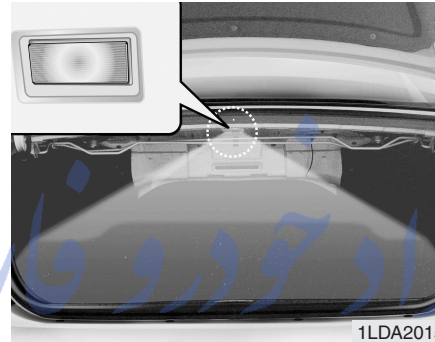

Trunk room lamp

Trunk room lamp turns on when the trunk is opened. It remains on until the trunk is securely closed.

* NOTICE

Make sure to close the trunk securely. If it remains open while engine is not running, it may cause battery discharge because trunk room lamp remains on.



Inside the vehicle

To open the trunk from inside the vehicle push trunk lid release switch.

⚠ WARNING - Exhaust fumes

If you drive with the trunk lid open, you will draw dangerous exhaust fumes into your vehicle causing serious injury or death to vehicle occupants. Open trunk lids can also dangerously obscure rear view vision.

If you must drive with the trunk lid open, keep the air vents open so that additional outside air comes into the vehicle.



- 1
- 2
- 3
- 4
- 5
- 6
- 7
- 8
- 9

⚠ WARNING
No one should be allowed to occupy the trunk of the vehicle at any time. If the trunk is partially or totally latched and the person is unable to get out, severe injury or death could occur due to lack of ventilation, exhaust fumes and rapid heat build-up, or because of exposure to cold weather conditions. The trunk is also a highly dangerous location in the event of a crash because it is not a protected occupant space but merely a part of the vehicle's crush zone.

⚠ CAUTION
We recommend that cars be kept locked and keys be kept out of the reach of children, and that parents teach their children about the dangers of playing in trunks.

امداد خودرو فار

تلفن شبانه روزی: ۰۸۵-۸۸۸۶۲-۲۱

FarmaSOS.com

HOOD



Opening the hood:

1. Pull the release lever on the lower left side of the instrument panel to unlatch the hood. The hood should pop open slightly.

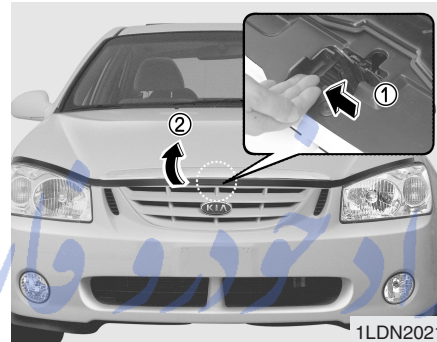

2. Go to the front of the vehicle, raise the hood slightly, push the secondary latch (①) inside of the hood centre and lift (②) the hood.

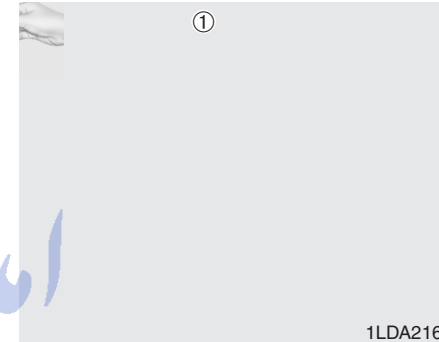

3. Lift the hood and hold it open with the support rod by inserting the free end of the rod into the slot (①).

CAUTION

Grasp the support rod in the area wrapped in rubber. The rubber will help prevent you from being burned by hot metal when the engine is hot.

- 1
- 2
- 3
- 4
- 5
- 6
- 7
- 8
- 9

Closing the hood

1

1. Before closing the hood, check the following:

2

- All filler caps in engine compartment must be correctly installed.

3

- Gloves, rags or any other combustible material must be removed from the engine compartment.

4

2. Secure the support rod in its clip.

5

3. Lower the hood to about 30 cm (12 inches) height and then let it drop to properly lock in place.

6

Make sure the hood is properly locked before driving.

7

8

9

CAUTION

- ***Before closing the hood, make sure that all engine parts and tools have been removed from the engine area and that no one's hands are near the hood opening.***
- ***Do not leave gloves, rags or any other combustible material in the engine compartment. Doing so may cause a heat-induced fire.***

تلفن شبانه روزی: ۰۲۱-۸۸۸۶۲۰۸۵

FarmaSOS.com

FUEL FILLER LID

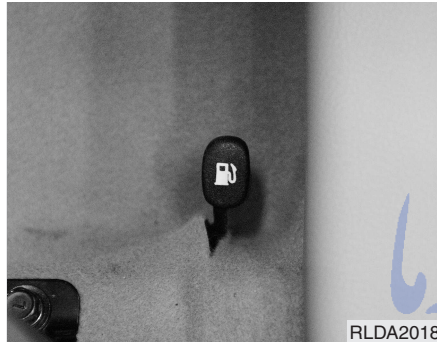

1. Stop the engine.
2. To open the fuel filler lid, pull the release lever.

CAUTION

To avoid injury from sharp objects, it is recommended that protective gloves be worn when opening the fuel filler door manually.



3. Pull the fuel filler lid out to open.
4. To remove the cap, turn the fuel tank cap counter-clockwise.
5. Refuel as needed.
6. To install the cap, turn it clockwise until it “clicks”. This indicates that the cap is securely tightened.
7. Close the fuel filler lid and push it lightly and make sure that it is securely closed.

WARNING - Refueling

If pressurized fuel sprays out, it can cause serious injuries. Always remove the fuel cap carefully and slowly. If the cap is venting fuel or if you hear a hissing sound, wait until the condition stops before completely removing the cap.

1

2

3

4

5

6

7

8

9

1

2

3

4

5

6

7

8

9

⚠ WARNING

Automotive fuels are flammable/explosive materials. When refueling, please note the following guidelines carefully. Failure to follow these guidelines may result in severe personal injury, severe burns or death by fire or explosion.

- Before refueling always note the location of the Emergency Gasoline Shut-Off, if available, at the gas station facility.
- Before touching the fuel nozzle or fuel filler cap, you should eliminate potentially dangerous static electricity discharge by touching another metal part of the front of the vehicle, a safe distance away from the fuel filler neck, nozzle, or other gas source.

(Continued)

(Continued)

- Do not get back into a vehicle once you have begun refueling. Do not touch, rub or slide against any item or fabric (polyester, satin, nylon, etc.) capable of producing static electricity. Static electricity discharge can ignite fuel vapors resulting in explosion. If you must re-enter the vehicle, you should once again eliminate potentially dangerous static electricity discharge by touching a metal part of the vehicle, away from the fuel filler neck, nozzle or other gasoline source.
- When using a portable fuel container be sure to place the container on the ground prior to refueling. Static electricity discharge from the container can ignite fuel vapors causing a fire. Once refueling has begun, contact with the vehicle should be maintained until the filling is complete.

(Continued)

(Continued)

- Use only portable fuel containers designed to carry and store gasoline.
- Do not use cellular phones around a gas station or while refueling any vehicle. Electric current and/or electronic interference from cellular phones can potentially ignite fuel vapors causing a fire. If you must use your cellular phone use it in a place away from the gas station.
- When refueling always shut the engine off. Sparks produced by electrical components related to the engine can ignite fuel vapors causing a fire. Always insure that the engine is OFF before and during refueling. Once refueling is complete, check to make sure the fuel filler cap and door are securely closed, before starting the engine.

(Continued)

(Continued)

- Do not light any fire around a gas station. DO NOT use matches or a lighter and DO NOT SMOKE or leave a lit cigarette in your vehicle while at a gas station especially during refueling. Automotive fuel is highly flammable and can, when ignited, result in explosion by flames.
- If a fire breaks out during refueling, leave the vicinity of the vehicle, and immediately contact the manager of the gas station or contact the police and local fire department. Follow any safety instructions they provide.

*** NOTICE**

- Make sure to refuel with gasoline only for the gasoline engine vehicles and diesel fuel only for the diesel engine vehicles.
- Check to make sure the fuel filler cap is securely closed after refueling.
- If the fuel filler cap requires replacement, use only a genuine Kia cap or the equivalent specified for your vehicle. An incorrect fuel filler cap can result in a serious malfunction of the fuel system or emission control system. Correct replacement caps are available at authorized Kia dealers.
- Do not spill fuel on the exterior surfaces of the vehicle. Any type of fuel spilled on painted surfaces may damage the paint.
- If the fuel filler lid will not open in cold weather because the area around it is frozen, push or lightly tap the lid.

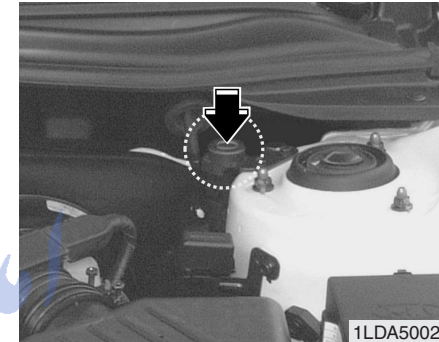

Auto fuel cutoff switch (if equipped)

The auto fuel cutoff switch is located on the passenger's side of the engine compartment. In the event of a collision or sudden impact, the auto fuel cutoff device cuts off the fuel supply. If this device is activated, it must be reset by pressing in on the top of the switch before the engine can be restarted.

⚠ WARNING

Before resetting the auto fuel cutoff switch, the fuel line should be checked for fuel leaks.

- 1
- 2
- 3
- 4
- 5
- 6
- 7
- 8
- 9

MIRRORS

Outside rearview mirror

Be sure to adjust mirror angles before driving.

1

2

3

4

5

6

7

8

9

Your vehicle is equipped with both left-hand and right-hand outside rearview mirrors. The mirrors can be adjusted remotely with the control levers or remote switch, depending on the type of mirror control installed. The mirror heads can be folded back to prevent damage during an automatic car wash or when passing in a narrow street.

CAUTION

- *The left outside rearview mirror is convex. In some countries, the right outside rearview mirror is also convex. Objects seen in the mirror are closer than they appear.*
- *Use your interior rearview mirror or direct observation to determine the actual distance of following vehicles when changing lanes.*

* NOTICE

Do not scrape ice off the mirror face; this may damage the surface of the glass. If ice should restrict movement of the mirror, do not force the mirror for adjustment. To remove ice, use a deicer spray, or a sponge or soft cloth with very warm water.

تلفن شبانه روزی: ۰۲۱-۸۸۸۶۲۰۸۵

FarmaSOS.com

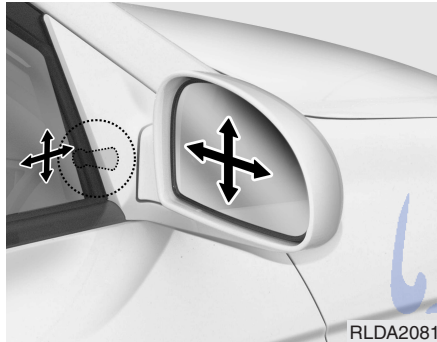

RLDA2081

**Manual remote control
(if equipped)**

To adjust an outside mirror, move the control lever which is located at the forward inside area of the window frame.



RLDN2080

**Electric remote control
(if equipped)**

The electric remote control mirror switch allows you to adjust the position of the left and right outside rearview mirrors. To adjust the position of either mirror, move the lever (①) to R or L to select the right side mirror or the left side mirror, then press a corresponding point (•) on the mirror adjustment control to position the selected mirror up, down, left or right.

After adjustment, put the lever into neutral position to prevent the inadvertent adjustment.

*** NOTICE - Electric mirror**

- The mirrors stop moving when they reach the maximum adjusting angles, but the motor continues to operate while the switch is depressed. Do not depress the switch longer than necessary, the motor may be damaged.
- Do not attempt to adjust the outside rearview mirror by hands. Doing so may damage the parts.

1
2
3
4
5
6
7
8
9

- 1
- 2
- 3
- 4
- 5
- 6
- 7
- 8
- 9

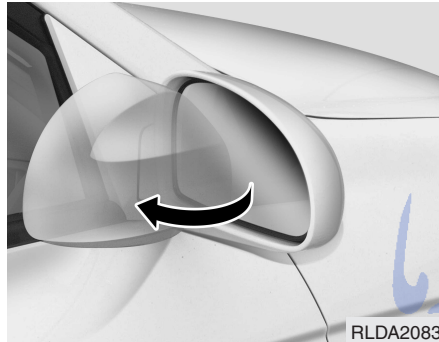

Folding the outside rearview mirror

To fold outside rearview mirror, grasp the housing of mirror and then fold it toward the rear of the vehicle.

Outside rearview mirror heater (if equipped)

The outside rearview mirror heater is actuated in connection with the rear window defroster. To heat the outside rearview mirror glass, push the button for the rear window defroster.

The outside rearview mirror glass will be heated for defrosting or defogging and will give you improved rear vision in inclement weather conditions. Push the button again to turn the heater off. The outside rearview mirror heater automatically turns off after 20 minutes.

Day/night rearview mirror

Adjust the rearview mirror to centre on the view through the rear window. Make this adjustment before you start driving.

CAUTION
Do not place objects in the rear seat or cargo area which would interfere with your vision out the rear window.

FarmaSOS.com

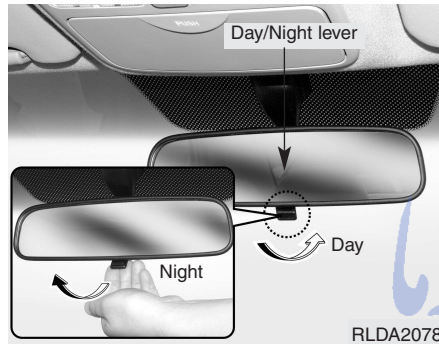

Manual type

Make this adjustment before you start driving and while the day/night lever is in the day position.

Pull the day/night lever toward you to reduce glare from the headlights of vehicles behind you during night driving.

Remember that you lose some rearview clarity in the night position.



Electric type (if equipped)

When the engine is running, the glare is automatically controlled by the sensor mounted in the rearview mirror. The sensor mounted in the mirror senses the light level around the vehicle, and through a chemical reaction, automatically controls the headlight glare from vehicles behind you.

Whenever the shift lever is shifted into reverse (R), the mirror will automatically go to the brightest setting in order to improve the drivers view behind the vehicle.

When the ignition switch is ON, the automatic- dimming function will turn on automatically.

Press the ON/OFF button (1) to turn the automatic- dimming function off. The mirror indicator light will turn off.

Press the ON/OFF button (1) once again to turn the automatic- dimming function on, the mirror indicator light will illuminate.

*** NOTICE**

When cleaning the mirror, use a paper towel or similar material dampened with glass cleaner. Do not spray glass cleaner directly on the mirror as that may cause the liquid cleaner to enter the mirror housing.

- 1
- 2
- 3
- 4
- 5
- 6
- 7
- 8
- 9

INTERIOR LIGHTS

- 1
- 2
- 3
- 4
- 5
- 6
- 7
- 8
- 9

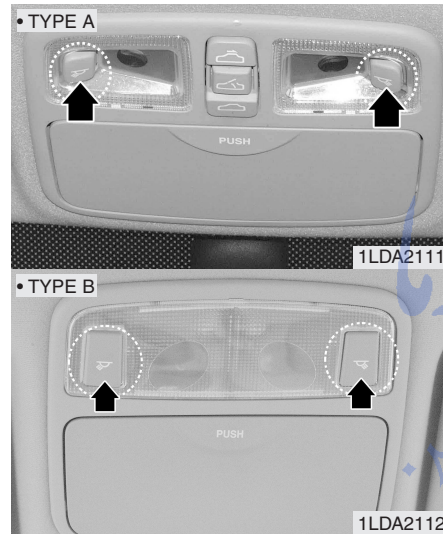

Map light

Front (if equipped)

The lights are turned ON or OFF by pressing the corresponding switch.

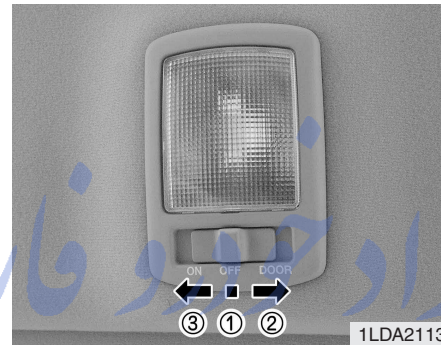

Dome light (if equipped)

- ① OFF - The light stays off even when a door is open.
- ② DOOR - The light turns on, or off when a door is opened or closed.

Interior light goes out slowly if the door is closed.

When a door is unlocked by the transmitter, interior light stays on for 30 seconds as long as the door is not opened.

- ③ ON - The light turns on and stays on even when the doors are all closed.

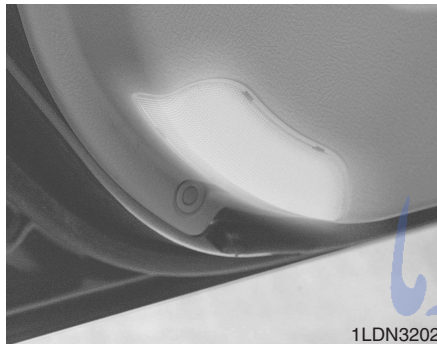

1LDN3202

**Door courtesy lamp
(if equipped)**

The door courtesy lamp comes ON when the door is opened to assist entering or exiting the vehicle. It also serves as a warning to passing vehicles that the vehicle door is open.

امداد خودرو فارما

تلفن شبانه روزی: ۰۸۵-۸۸۸۶۲-۱

FarmaSOS.com

1

2

3

4

5

6

7

8

9

STORAGE COMPARTMENT

* NOTICE

- To avoid possible theft, do not leave valuables in the storage compartment.
- Since stored items may move while driving, be sure to position them in the storage compartment so that they do not make noise or cause a potential safety hazard when the vehicle is moving.
- Always keep the storage compartment covers closed while driving. Do not attempt to place many items in the storage compartment that the storage compartment cover can not close securely.

⚠ WARNING
Do not store cigarette lighters, propane cylinders, or other flammable/explosive materials in the vehicle. These items may catch fire and/or explode if the vehicle is exposed to hot temperatures for extended periods.

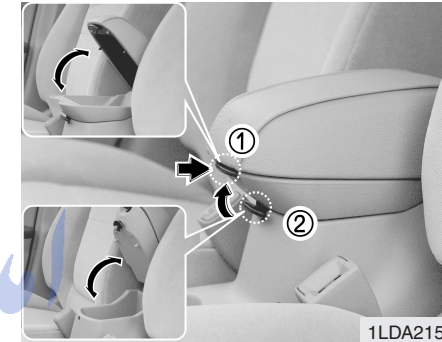

Centre console storage

To open either of the console storage compartments, pull up on the locking tab ① or ②.

These compartments can be used to store small items required by the driver or front passenger.

- 1
- 2
- 3
- 4
- 5
- 6
- 7
- 8
- 9



Multi box

Rear (if equipped)

To open the storage compartment, pull the armrest down and pull up on the locking tab (①). It can be used for storing small items.

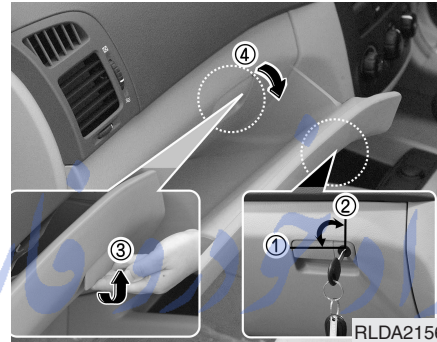

Glove box

The glove box can be locked (①) and unlocked (②) with a master key. (if equipped)

To open the glove box, make sure it is unlocked, then pull the handle (③) and the glove box will automatically open (④). Close the glove box after use.

*** NOTICE**

Since key is not fully inserted into the glove box key set, do not apply excessive force. Doing so may damage the parts.

CAUTION

To reduce the risk of injury in case of an accident or sudden stop, always keep the glove box door closed while driving.

- 1
- 2
- 3
- 4
- 5
- 6
- 7
- 8
- 9

FarmaSOS.com

- 1
- 2
- 3
- 4
- 5
- 6
- 7
- 8
- 9

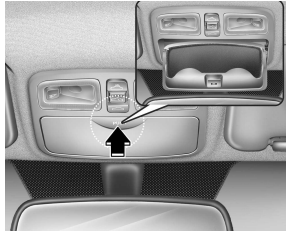

*** NOTICE**

Make sure the sunglasses holder is closed while driving.

امداد خودرو فارما

1LDA2159

Sunglass holder

A sunglasses storage compartment is provided on the overhead console. To open the sunglasses holder, press the cover and the holder will slowly open. Place your sunglasses in the compartment door with the lenses facing out. Push to close.

تلفن شبانه روزی: ۰۸۵-۸۸۸۶۲-۲۱

FarmaSOS.com

INTERIOR FEATURES

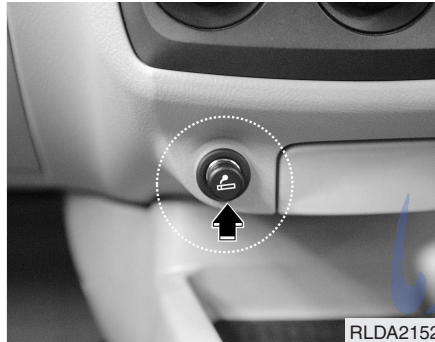

Cigarette lighter

Front

To operate the cigarette lighter, press it in and release it. When it is heated, it automatically pops out ready for use.

If the engine is not running, the ignition switch must be in the ACC position for the lighter to operate.

* NOTICE

- Do not hold the lighter in after it is already heated because it will overheat.
- Only a genuine Kia lighter should be used in the cigarette lighter socket. The use of plug-in accessories (shavers, hand-held vacuums, and coffee pots, for example) may damage the socket or cause electrical failure.
- If the lighter does not pop out within 30 seconds, remove it to prevent overheating.

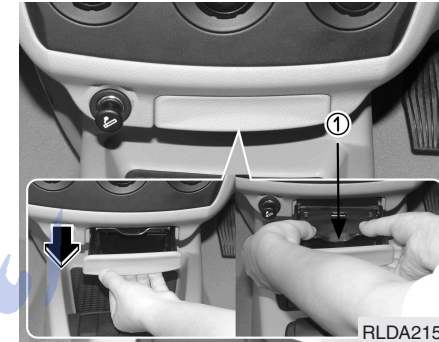

Ashtrays

Front

To use the ashtray, pull it out.

To remove the ashtray to empty or clean it, push the tab (1) inside and pull it all the way out.

1

2

3

4

5

6

7

8

9

- 1
- 2
- 3
- 4
- 5
- 6
- 7
- 8
- 9

⚠ WARNING - Ashtray use

- Do not use the vehicle's ashtrays as waste receptacles.
- Putting lit cigarettes or matches in an ashtray with other combustible materials may cause a fire.

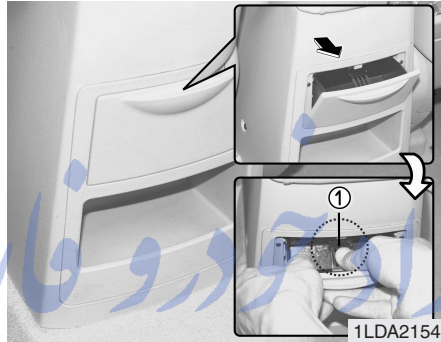

Rear (if equipped)

You can open the rear ashtray by pulling it out by its top edge. To remove the ashtray to empty or clean it, push the tab (1) inside and pull it all the way out.

Cup holder

⚠ WARNING - Hot liquids

- Do not place uncovered cups of hot liquid in the cup holder while the vehicle is in motion. If the hot liquid spills, you could be burned. Such a burn to the driver could cause a loss of control of the vehicle.
- To reduce the risk of personal injury in the event of sudden stop or collision, do not place uncovered or insecure bottles, glasses, cans, etc., in the cup holder while the vehicle is in motion.

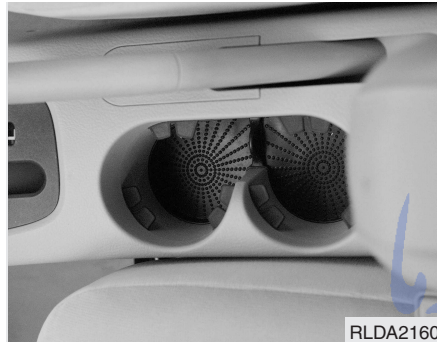

Front

Cups or small beverage cans may be placed in the cup holders.



Rear (if equipped)

To use the cup holders in rear seat, pull the rear cup holder cover (①) out. Push the cover to close after use.

*** NOTICE**

Do not place heavy cups or cans in cup holders. Cup holders could be damaged.

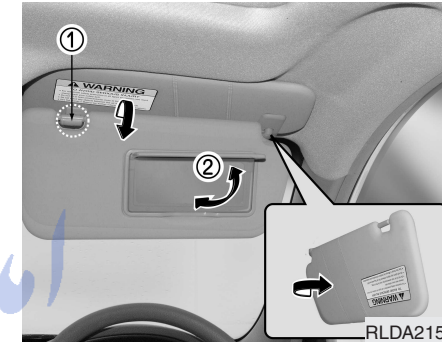

Sunvisor

Use the sunvisor to shield direct light through the front or side windows.

To use a sunvisor, pull it downward.

To use a sunvisor for a side window, pull it downward, unsnap it from the bracket (①) and swing it to the side.

To use the vanity mirror, pull down the visor and pull up the mirror cover (②).

- 1
- 2
- 3
- 4
- 5
- 6
- 7
- 8
- 9

- 1
- 2
- 3**
- 4
- 5
- 6
- 7
- 8
- 9

*** NOTICE**

Close the vanity mirror cover securely and return the sunvisor to its original position after use.

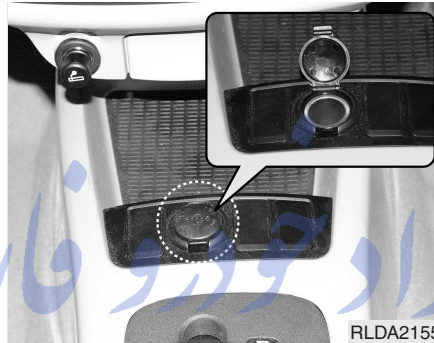

Power socket (if equipped)

The power outlets are designed to provide power for mobile telephones or other devices designed to operate with vehicle electrical systems. The devices should draw less than 10 amps with the engine running.

*** NOTICE**

- Use the power outlet when the engine is running, and remove a plug from the power outlet after using the electric appliance. Using when the engine stops or remaining plugged in for many hours may cause the battery to be discharged.
- Only use the electric appliances which are less than 12V and 10A in electric capacity.
- Adjust the air-conditioner or heater to the lowest operation level when you have to use the power socket while using air-conditioner or heater.
- Some electronic devices can cause electronic interference when plugged into a vehicle's power outlet. These devices may cause excessive audio static and malfunctions in other electronic systems or devices used in your vehicle.

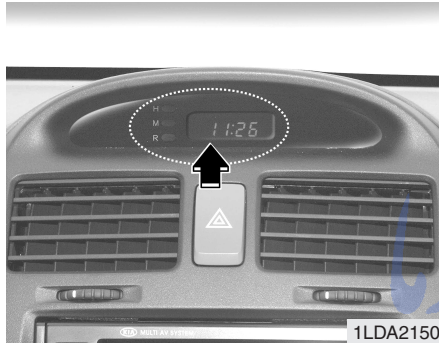

Digital clock (if equipped)

Whenever the battery terminals, ROOM fuse, or Power Connect are disconnected, you must reset the time.

When the ignition switch is in the ACC or ON position, the clock buttons operates as follows:

• **HOUR:**

Pressing the “H” button with your finger, a pencil or similar object will advance the time displayed by one hour.

• **MINUTE:**

Pressing the “M” button with your finger, a pencil or similar object will advance the time displayed by one minute.

• **RESET:**

To clear away minutes, press the “R” button with your finger, a pencil or similar object. Then the clock will be set precisely on the hour.

For example, if the “R” button is pressed while the time is between 9:01 and 9:29, the display will be reset to 9:00.

9:01 ~ 9:29 ⇒ 9:00

9:30 ~ 9:59 ⇒ 10:00

- 1
- 2
- 3
- 4
- 5
- 6
- 7
- 8
- 9

FarmaSOS.com

SUNROOF (IF EQUIPPED)

- 1
- 2
- 3
- 4
- 5
- 6
- 7
- 8
- 9



If your vehicle is equipped with this feature, you can slide or tilt your sunroof with the sunroof control buttons located on the overhead console.

The sunroof can only be opened, closed, or tilted when the ignition switch is in the "ON" position.

* NOTICE

- Do not continue to press the sunroof control button(s) after the sunroof is in the fully open, closed, or tilt position(s). Damage to the motor or system components could occur.
- The sunroof cannot slide when it is in the tilt position nor can it be tilted while in an open or slide position.

Sliding the sunroof

Autoslide open

To use the autoslide feature, momentarily (less than 0.5 second) press the SLIDE OPEN () button on the overhead console. The sunroof will slide all the way open. To stop the sunroof sliding at any point, press any sunroof control button.

Manual slide open

Press the SLIDE OPEN () button on the overhead console for more than 0.5 second.

Close

To close the sunroof, press the CLOSE () button on the overhead console and hold it until the sunroof is closed.

Tilting the sunroof

Autotilt open

To use the autotilt feature, momentarily (less than 0.5 second) press the TILT UP (⏮) button on the overhead console. The sunroof will tilt all the way open. To stop the sunroof tilting at any point, press any sunroof control button.

Manual tilt open

Press the TILT UP (⏮) button on the overhead console for more than 0.5 second.

Close

To close the sunroof, press the CLOSE (⏭) button on the overhead console and hold it until the sunroof is closed.

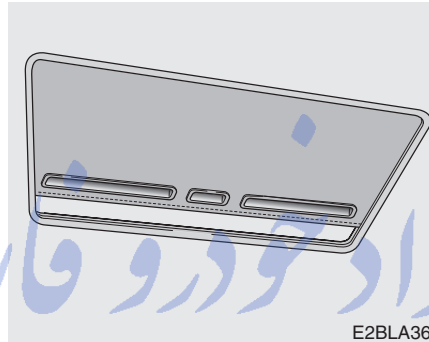

Sunshade

The sunshade will be opened with the glass panel automatically when the glass panel is slid. You will have to close it manually if you want it closed.

* NOTICE

- Do not press any sunroof control button longer than necessary. Damage to the motor or system components could occur.
- Periodically remove any dirt that may accumulate on the guide rail.
- If you try to open the sunroof when the temperature is below freezing or when the sunroof is covered with snow or ice, the glass or the motor could be damaged.
- The sunroof is made to slide together with sunshade. Do not leave the sunshade closed while the sunroof is open.

⚠ WARNING

- Do not extend face or arms outside through the sunroof opening while driving.
- Make sure hand and face are safely out of the way before closing a sunroof.

1
2
3
4
5
6
7
8
9

- 1
- 2
- 3**
- 4
- 5
- 6
- 7
- 8
- 9

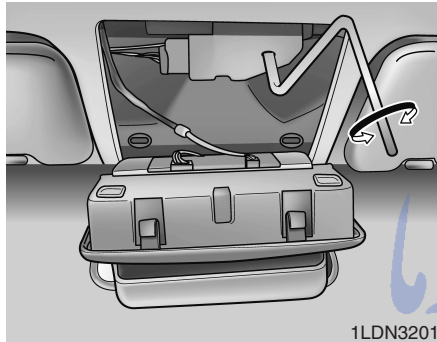

In case of an emergency

If the sunroof does not open electrically:

1. Open the sunglasses holder.
2. Remove the two (2) screws, and then remove the overhead console.
3. Insert the emergency handle (provided with the vehicle) and turn the handle clockwise to open or counterclockwise to close.

Resetting the sunroof

Whenever the vehicle battery is disconnected or discharged, or you use the emergency handle to operate the sunroof, you have to reset your sunroof system as follows:

1. Turn the ignition key to the ON position.
2. According to the position of the sunroof, do as follows.
 - 1) in case that the sunroof has closed completely or been tilted
: Press the TILT UP (↗) button for 1 second.
 - 2) in case that the sunroof has slide-opened
: Press and hold the CLOSE (↖) button for more than 5 seconds until the sunroof has closed completely. And then press the TILT UP (↗) button for 1 second

3. Then, release it.
4. Press and hold the TILT UP (↗) button once again until the sunroof has returned to the original position of TILT UP (↗) after it is raised a little higher than the maximum TILT UP (↗) position.

When this is complete, the sunroof system is reset.

LUGGAGE NET (IF EQUIPPED)

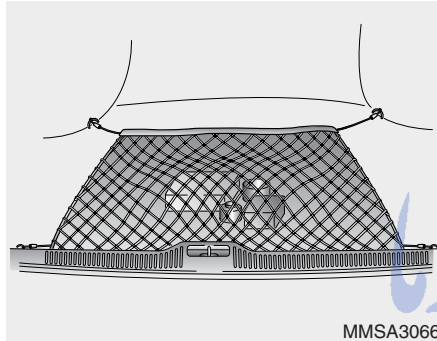

To keep items from shifting in the trunk, you can use the four rings located in the trunk to attach the cargo net.

* NOTICE

Do not put fragile, bulky or an excessive quantity of items into luggage net. They could be damaged.

⚠ WARNING

To avoid eye injury, DO NOT overstretch the netting.

ALWAYS keep face and body out of recoil path of the net, in case of strap.

DO NOT use the luggage net when strap has visible signs of wear or damage.

1

2

3

4

5

6

7

8

9

FarmaSOS.com

تلفن شبانه روزی: ۰۲۱-۸۸۸۶۲۰۸۵

ANTENNA

1

2

3

4

5

6

7

8

9

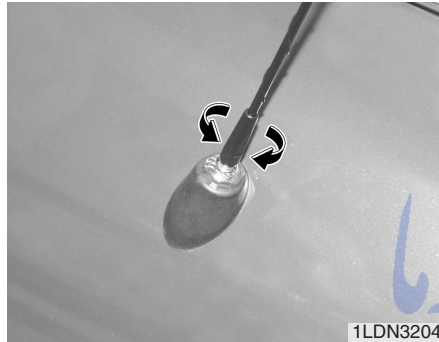

Fixed rod antenna (if equipped)

Your car uses a fixed rod antenna to receive both AM and FM broadcast signals.

This antenna is removable. To remove the antenna, turn it counter-clockwise. To install the antenna, turn it clockwise.

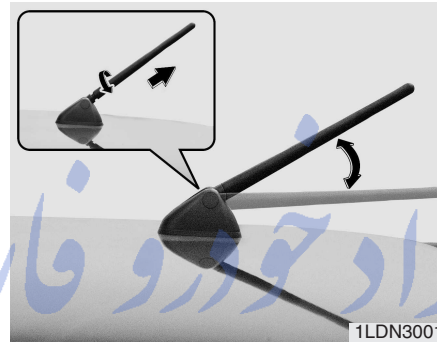

Roof type antenna (if equipped)

If your vehicle has an audio system, an amplifying antenna is installed in your vehicle.

This antenna can be adjusted up and down or removed from the vehicle when you wash your vehicle.

* NOTICE

- Be sure to remove the antenna before washing the car in an automatic car wash or it may be damaged.
- When reinstalling your antenna, it is important that it is fully tightened to ensure proper reception.

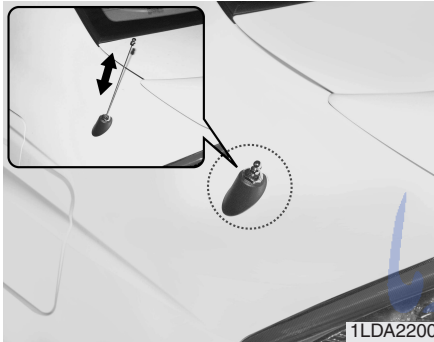

Manual antenna (if equipped)

Your car uses a manual stainless steel antenna to receive both AM and FM broadcast signals. Pull up the antenna using your fingers, as shown in the drawing.

*** NOTICE**

Before entering an automatic car wash or a place with a low height clearance, be sure that the antenna is fully retracted.



Power antenna (if equipped)

The antenna will automatically be extended when the radio power switch is turned "ON" while the ignition key is either in the "ON" or "ACC" position. The antenna will automatically be retracted and stored when either the radio power switch is turned "OFF" or the ignition key is set to the "LOCK" position.

CAUTION

Before turning on the radio, make sure that no one is near the antenna.

*** NOTICE**

- Before entering an automatic car wash or a place with a low height clearance, be sure that the antenna is retracted and stored.
- If the antenna is dirty, be sure to clean it in order to avoid an operation malfunction.

- 1
- 2
- 3
- 4
- 5
- 6
- 7
- 8
- 9

ایجاد خود و فارما

روزه: ۰۲۱-۸۸۸۶۲۰۸۵

FarmaSOS.com

Ignition switch / 4-2	1
Starting the engine / 4-4	
Manual transaxle / 4-7	2
Automatic transaxle / 4-8	
Brake system / 4-15	
Steering wheel / 4-22	3
Cruise control system / 4-25	

Driving your vehicle 4

Traction control system / 4-30	5
Instrument cluster / 4-33	
Gauges / 4-34	
Warnings and indicators / 4-38	6
Lighting / 4-46	
Wipers and washers / 4-52	7
Defroster / 4-55	
Hazard warning flasher / 4-56	
Manual climate control system / 4-57	8
Automatic climate control system / 4-66	
Windshield defrosting and defogging / 4-79	
Theft-alarm system / 4-84	9

IGNITION SWITCH

1

2

3

4

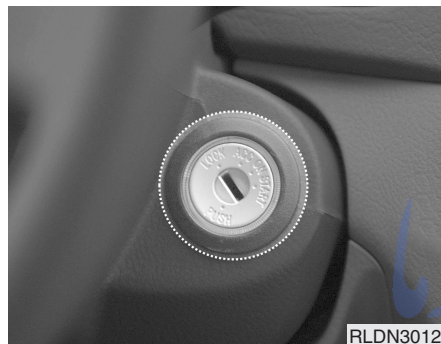

ILLUMINATED IGNITION SWITCH (if equipped)

Whenever a door is opened, the ignition switch will be illuminated for your convenience, provided the ignition switch is not in the ON position. The light will go off approximately 10 seconds after closing the door or when the ignition switch is turned on.

5

6

7

8

9



IGNITION SWITCH AND ANTI-THEFT STEERING COLUMN LOCK

Ignition switch position

LOCK

The steering wheel locks to protect against theft. The ignition key can be removed only in the LOCK position. When turning the ignition switch to the LOCK position, push the key inward at the ACC position and turn the key toward the LOCK position.

ACC (Accessory)

The steering wheel is unlocked and electrical accessories are operative.

ON

The warning lights can be checked before the engine is started. This is the normal running position after the engine is started.

Do not leave the ignition switch ON if the engine is not running to prevent battery discharge.

START

Turn the ignition key to the START position to start the engine. The engine will crank until you release the key; then it returns to the ON position. The brake warning lamp can be checked in this position.

If difficulty is experienced in turning the ignition key to the START position, turn the steering wheel right and left to release the tension and then turn the key.

⚠ WARNING - Ignition key

- Never turn the ignition switch to LOCK or ACC while the vehicle is moving. This would result in loss of directional control and braking function, which could cause an immediate accident.
- The anti-theft steering column lock is not a substitute for the parking brake. Before leaving the driver's seat, always make sure the shift lever is engaged in 1st gear for manual transaxle or P (Park) for automatic transaxle, set the parking brake fully and shut the engine off. Unexpected and sudden vehicle movement may occur if these precautions are not taken.

(Continued)

(Continued)

- Never reach for the ignition switch, or any other controls through the steering wheel while the vehicle is in motion. The presence of your hand or arm in this area could cause a loss of vehicle control, an accident and serious bodily injury or death.
- Do not place any movable objects around the driver's seat as they may move while driving, interfere with the driver and lead to an accident.

1

2

3

4

5

6

7

8

9

STARTING THE ENGINE

Starting the gasoline engine

1. Make sure the parking brake is applied.
2. **Manual Transaxle** - Depress the clutch pedal fully and shift the transaxle into Neutral. Keep the clutch pedal depressed while turning the ignition switch to the start position.

Automatic Transaxle - Place the transaxle shift lever in P (Park). Depress the brake pedal fully.

You can also start the engine when the shift lever is in the N (Neutral) position.

3. Turn the ignition switch to START and hold it there until the engine starts (a maximum of 10 seconds), then release the key.
4. In extremely cold weather (below -18°C / 0°F) or after the vehicle has not been operated for several days, let the engine warm up without depressing the accelerator.

*Whether the engine is cold or warm, it should be started **without depressing the accelerator.***

CAUTION

If the engine stalls while you are in motion, do not attempt to move the shift lever to the P (Park) position. If traffic and road conditions permit, you may put the shift lever in the N (Neutral) position while the vehicle is still moving and turn the ignition switch to the START position in an attempt to restart the engine.

* NOTICE

Do not engage the starter for more than 10 seconds. If the engine stalls or fails to start, wait 5 to 10 seconds before re-engaging the starter. Improper use of the starter may damage it.

1

2

3

4

5

6

7

8

9

Starting the diesel engine

To start the diesel engine when the engine is cold, it has to be pre-heated before starting the engine and then have to be warmed up before starting the driving.

1. Make sure the parking brake is applied.
2. **Manual Transaxle** - Depress the clutch pedal fully and shift the Transaxle into the Neutral. Keep the clutch pedal depressed while cranking the engine.

Automatic Transaxle - Place the Transaxle shift lever in P(park). Depress the brake pedal fully.

You can also start the engine when the shift lever is in the N(neutral) position.

3. Turn the ignition switch ON position to pre-heat the engine. Then the glow indicator light will illuminate.



4. If the glow indicator light goes out, turn the ignition switch to START and hold it there until the engine starts (a maximum of 10 seconds), then release the key.

* NOTICE

If the engine were not started within 2 seconds after the preheating is completed, turn the ignition key once more to the LOCK position during 10 seconds, and then to the ON position, in order to preheat again.

1

2

3

4

5

6

7

8

9

Starting and stopping the engine for turbo charger intercooler

1

1. Do not race or accelerate the engine immediately after starting.

2

If the engine is cold, allow the engine to idle for several seconds before it is driven to ensure sufficient lubrication of the turbo charger unit.

3

4

2. After high speed or extended driving, requiring a heavy engine load, the engine should be allowed to idle, as shown in the chart below, before turning it off.

5

6

This idle time will allow the turbo charger to cool prior to shutting the engine off.

7

8

9

Driving Condition		Required Idle Time
Normal driving		Not necessary
High speed driving	Up to 80 km/h	About 20 seconds
	Up to 100 km/h	About 1 minute
Steep mountain slopes or continued driving in excess of 100 km/h		About 2 minutes

⚠ WARNING

Do not turn the engine off immediately after it has been subjected to a heavy load. Doing so may cause severe damage to the engine or turbo charger unit.

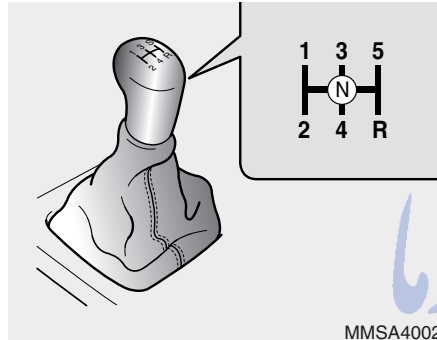
MANUAL TRANSAXLE (IF EQUIPPED)

MMSA4002

Manual transaxle operation

The manual transaxle has five forward gears.

Press the clutch pedal down fully while shifting, then release it slowly.

A special safety feature prevents inadvertent shifting from 5 (Fifth) to R (Reverse). The gearshift lever must be returned to the neutral position before shifting into R (Reverse).

Make sure the vehicle is completely stopped before shifting into R (Reverse).

Never operate the engine with the tachometer (rpm) in the red zone.

*** NOTICE**

To avoid premature clutch wear and damage, do not drive with your foot resting on the clutch pedal. Also, don't use the clutch to hold the vehicle stopped on an upgrade, while waiting for a traffic light, etc.

⚠ WARNING - Manual transaxle

Before leaving the driver's seat, always set the parking brake fully and shut the engine off. Then make sure the transaxle is shifted into 1st gear when the vehicle is parked on a level or uphill grade, and shifted into R (Reverse) on a downhill grade. Unexpected and sudden vehicle movement can occur if these precautions are not followed in the order identified.

Downshifting

When you must slow down in heavy traffic or while driving up steep hills, downshift before the engine starts to labor. Downshifting reduces the chance of stalling and gives better acceleration when you again need to increase your speed. When the vehicle is traveling down steep hills, downshifting helps maintain safe speed and prolongs brake life.

1

2

3

4

5

6

7

8

9

AUTOMATIC TRANSAXLE (IF EQUIPPED)

- 1
- 2
- 3
- 4**
- 5
- 6
- 7
- 8
- 9

■ Type A

Lock release button prevents shift lever movement without first depressing the button.

O/D button

■ Type B

Lock release button prevents shift lever movement without first depressing the button.

Legend:

- Depress the brake pedal and push the button when shifting.
- The lock release button must be depressed while moving the shift lever.
- The shift lever can be moved without depressing the lock release button.

RLDA3019

Automatic transaxle operation

All normal forward driving is done with the shift lever in the D (Drive) position.

To move the shift lever from the P (Park) position, the brake pedal must be depressed and the lock release button must be depressed.

For smooth operation, depress the brake pedal when shifting from N (Neutral) to a forward or reverse gear.

⚠ WARNING - Automatic transaxle

Before leaving the driver's seat, always make sure the shift lever is in the P (PARK) position; then set the parking brake fully and shut the engine off. Unexpected and sudden vehicle movement can occur if these precautions are not followed in the order identified.

* NOTICE

- To avoid damage to your transaxle, do not accelerate the engine in R (Reverse) or any forward gear position with the brakes on.
- When stopped on an upgrade, do not hold the vehicle stationary with engine power. Use the service brake or the parking brake.
- Do not shift from N (Neutral) or P (Park) into D (Drive), or R (Reverse) when the engine is above idle speed.

1

2

3

4

5

6

7

8

9

FarmaSOS.com

Transaxle ranges

P (park)

1 This position locks the transaxle and prevents the front wheels from rotating. Always come to a complete stop before shifting into this position.

2

*** NOTICE**

3 The transaxle may be damaged if you shift into P (Park) while the vehicle is in motion.

4

5

6

7

8

9

⚠ WARNING

- Shifting into P (Park) while the vehicle is in motion will cause the drive wheels to lock which will cause you to lose control of the vehicle.
- Do not use the P (Park) position in place of the parking brake. Always make sure the shift lever is latched in the P (Park) position so that it cannot be moved unless the lock release button is pushed in, AND set the parking brake fully.

(Continued)

(Continued)

- Before leaving the driver's seat, always make sure the shift lever is in the P (PARK) position. Set the parking brake fully, shut the engine off and take the key with you. Unexpected and sudden vehicle movement can occur if you do not follow these precautions in the order specified.
- Never leave a child unattended in a vehicle.

FarmaSOS.com

R (reverse)

Use this position to drive the vehicle backward.

*** NOTICE**

Always come to a complete stop before shifting into or out of R (Reverse); you may damage the transaxle if you shift into R while the vehicle is in motion, except as explained in “Rocking the Vehicle”, in this manual.

N (neutral)

With the gearshift in the N position, the wheels and transaxle are not locked. The vehicle will roll freely even on the slightest incline unless the parking brake or service brakes are applied.

D (drive)

This is the normal forward driving position. The transaxle will automatically shift through a 4-gear sequence, providing the best fuel economy and power.

For extra power when passing another vehicle or climbing grades, depress the accelerator fully, at which time the transaxle will automatically downshift to the next lower gear.

1

2

3

4

5

6

7

8

9

تلفن شبانه روزی: ۰۲۱-۸۸۸۶۲۰۸۵

FarmaSOS.com

- 1
- 2
- 3
- 4**
- 5
- 6
- 7
- 8
- 9

3 (Third Gear, if equipped)

Move the shift lever to this position for towing a trailer during hill climbing.

This position also provides engine braking when going down hills.

2 (Second Gear)

Use 2 (Second Gear) for more power when climbing hills and for increased braking when going down hills. This position also helps reduce wheel spin on slippery surfaces. When the shift lever is placed in 2 (Second Gear), the transaxle will automatically shift from first to second gear.

L (Low)

Move the shift lever to this position in hard pulling situations and for climbing steep grades.

CAUTION

Do not exceed the recommended maximum speeds in 2 (Second Gear) or L (Low). Operating the vehicle at speeds above the maximum recommended, for 2 (Second Gear) or L (Low) may cause excessive heat to develop which could result in damage to or failure of the automatic transaxle.

تلفن شبانه روزی: ۰۲۱-۸۸۸۶۲۰۸۵

FarmaSOS.com



**O/D (Over Drive) system
(if equipped)**

Pressing the O/D system button cancels and engages the overdrive system. When the O/D system is cancelled, the O/D OFF indicator illuminates and the transaxle gear range is limited to 1st through 3rd. The transaxle will not shift to 4th gear until the O/D system button is pressed again to release the switch.

When driving down a sloping road with the transaxle in O/D (4th), you can decrease the vehicle speed without using the brakes by pressing the O/D button.

When the ignition is switched OFF, O/D OFF mode is automatically cancelled.

O/D OFF Indicator

This indicator light illuminates in the instrument panel when the O/D mode is cancelled.

*** NOTICE**

If the O/D OFF indicator flashes, it indicates an electrical problem with the transaxle. Should this occur, have the vehicle checked by an Authorized Kia Dealer as soon as possible, except as explained in "Rocking the Vehicle".

- 1
- 2
- 3
- 4
- 5
- 6
- 7
- 8
- 9

آراد خودرو فارما

تلفن شبانه روزی: ۰۸۵-۸۸۸۶۲-۱

PharmaSOS.com

1

Moving up a steep grade from a standing start

To move up a steep grade from a standing start, depress the brake pedal, shift the shift lever to D (Drive). Select the appropriate gear depending on load weight and steepness of the grade, and release the parking brake. Depress the accelerator gradually while releasing the service brakes.

2

3

4

5

6

7

8

9

Shift lock system (if equipped)

For your safety, the Automatic Transaxle has a shift lock system which prevents shifting the transaxle out of P (Park) unless the brake pedal is depressed.

- **Type A**

1. Depress and hold the brake pedal.
2. Depress the lock release button and move the shift lever.

- **Type B (If the ignition key interlock system is equipped)**

1. Depress and hold the brake pedal.
2. Start the engine or turn the ignition to the ON position.
3. Depress the lock release button and move the shift lever.

If the brake pedal is repeatedly depressed and released with the shift lever in the P (Park) position, a chattering sound near the shift lever may be heard. This is a normal condition.

Ignition key interlock system (if equipped)

The ignition key cannot be removed unless the shift lever is in the P (Park) position. If the ignition switch is in any other position, the key cannot be removed.

BRAKE SYSTEM

Power brakes

Your vehicle has power-assisted brakes that adjust automatically through normal usage.

In the event that the power-assisted brakes lose power because of a stalled engine or some other reason, you can still stop your vehicle by applying greater force to the brake pedal than you normally would. The stopping distance, however, will be longer.

When the engine is not running, the reserve brake power is partially depleted each time the brake pedal is applied. Do not pump the brake pedal when the power assist has been interrupted.

Pump the brake pedal only when necessary to maintain steering control on slippery surfaces.

In the event of brake failure

If service brakes fail to operate while the vehicle is in motion, you can make an emergency stop with the parking brake. The stopping distance, however, will be much greater than normal.

⚠ WARNING - Parking brake
 Depressing the parking brake while the vehicle is moving at normal speeds can cause a sudden loss of control of the vehicle. If you must use the parking brake to stop the vehicle, use great caution in applying the brake.

⚠ WARNING - Brakes

- Do not drive with your foot resting on the brake pedal. This will create abnormal high brake temperatures, excessive brake lining and pad wear, and increased stopping distances.
- When descending a long or steep hill, shift to a lower gear and avoid continuous application of the brakes. Continuous brake application will cause the brakes to overheat and could result in a temporary loss of braking performance.

(Continued)



- 1
- 2
- 3
- 4**
- 5
- 6
- 7
- 8
- 9

(Continued)

• **Wet brakes may result in the vehicle not slowing down at the usual rate and pulling to one side when the brakes are applied. Applying the brakes lightly will indicate whether they have been affected in this way. Always test your brakes in this fashion after driving through deep water. To dry the brakes, apply them lightly while maintaining a safe forward speed until brake performance returns to normal.**

Disc brakes wear indicator

Your vehicle has disc brakes.

When your brake pads are worn and it's time for new pads, you will hear a high-pitched warning sound from your front brakes or rear brakes (if equipped). You may hear this sound come and go or it may occur whenever you depress the brake pedal.

Please remember that some driving conditions or climates may cause a brake squeal when you first apply (or lightly apply) the brakes. This is normal and does not indicate a problem with your brakes.

* NOTICE

To avoid costly brake repairs, do not continue to drive with worn brake pads.

⚠ WARNING - Brake wear

This brake wear warning sound means your vehicle needs service. If you ignore this audible warning, you will eventually lose braking performance, which could lead to a serious accident.

⚠ CAUTION

Always replace brake pads as complete front or rear axle sets.

FarmaSOS.com



Parking brake

To apply the parking brake, pull the parking brake handle fully and firmly upward while applying the service brake.

CAUTION

Driving with the parking brake applied will cause excessive brake pad and brake rotor wear.

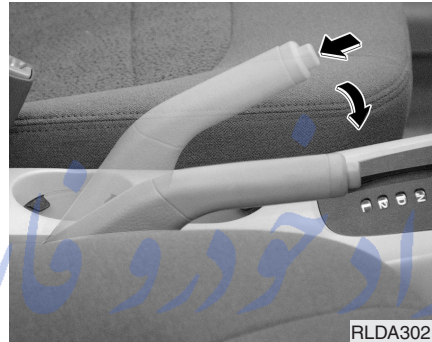

To release the parking brake, pull the handle up slightly and push the release button, then lower the handle to the released position while holding the button in.

⚠ WARNING - Parking brake

- To prevent unintentional movement when stopped and leaving the vehicle, do not use the gearshift lever in place of the parking brake. Set the parking brake AND make sure the gearshift lever is securely positioned in 1st (First) gear or R (Reverse) for manual transaxle equipped vehicles and in P (Park) for automatic transaxle equipped vehicles.
- Never allow a person who is unfamiliar with the vehicle or children to touch the parking brake. If the parking brake is released unintentionally, serious injury may occur.

- 1
- 2
- 3
- 4
- 5
- 6
- 7
- 8
- 9

armaSOS.com

1

2

3

4

5

6

7

8

9



Check the brake warning light by turning the ignition switch ON (do not start the engine). This light will be illuminated when the parking brake is applied with the ignition switch in the START or ON position.

Before driving, be sure the parking brake is fully released and the brake warning light is off.

If the brake warning light remains on after the parking brake is released, there may be a malfunction in the brake system. Immediate attention is necessary.

If at all possible, cease driving the vehicle immediately. If that is not possible, use extreme caution while operating the vehicle and only continue to drive the vehicle until you can reach a safe location or repair shop.

Parking on curbed streets

- When parking your vehicle on an uphill grade, park as close to the curb as possible and turn the front wheels away from the curb so that the front wheels will contact the curb if the vehicle moves backward.
- When parking your vehicle on a downhill grade, park as close to the curb as possible and turn the front wheels toward the curb so that the front wheels will contact the curb if the vehicle moves forward.

تلفن شبانه روزی: ۰۸۵-۸۸۸۶۲-۱

FarmaSOS.com

**Anti-lock brake system (ABS)
(if equipped)**

⚠ WARNING - ABS Brakes

Your ABS is not a substitute for good driving judgement. You can still have an accident. In fact, your ABS system will probably not be able to prevent an accident in the following driving conditions:

- Dangerous driving, such as neglecting safety precautions, speeding, or driving too close to the vehicle in front of you.
- Driving at high speed in situations providing considerably less traction, such as wet conditions where hydroplaning could occur.

(Continued)

(Continued)

- Driving too fast on poor road surfaces. The ABS is designed to improve maximum braking effectiveness on typical highways and roads in good condition. On poor road surfaces in poor condition, the ABS may actually reduce braking effectiveness.

The ABS system continuously senses the speed of the wheels. If the wheels are going to lock, the ABS system repeatedly modulates the hydraulic brake pressure to the wheels.

When you apply your brakes under conditions which may lock the wheels, you may hear a “tik-tik” sound from the brakes, or feel a corresponding sensation in the brake pedal. This is normal and it means your ABS system is active.

In order to obtain the maximum benefit from your ABS system in an emergency situation, do not attempt to modulate your brake pressure and do not try to pump your brakes. Press your brake pedal as hard as possible or as hard as the situation warrants and allow the ABS system to control the force being delivered to the brakes.



شبانہ روزی: ۸۵ + ۸۸۶۲ - ۲۱
PharmaSOS.com

- 1
- 2
- 3
- 4**
- 5
- 6
- 7
- 8
- 9

- Even with the anti-lock brake system, your vehicle still requires sufficient stopping distance. Always maintain a safe distance from the vehicle in front of you.
- Always slow down when cornering. The anti-lock brake system cannot prevent accidents resulting from excessive speeds.
- On loose or uneven road surfaces, operation of the anti-lock brake system may result in a longer stopping distance than for vehicles equipped with a conventional brake system.



*** NOTICE**

- If the ABS warning light is on and stays on, you may have a problem with the ABS system. In this case, however, your regular brakes will work normally.
- The ABS warning light will stay on for approximately 3 seconds after the ignition switch is ON. During that time, the ABS will go through self-diagnosis and the light will go off if everything is normal. If the light stays on, you may have a problem with your ABS system. Contact an authorized Kia dealer as soon as possible.

*** NOTICE**

- When you drive on a road having poor traction, such as an icy road, and operate your brakes continuously, the ABS will be active continuously and the ABS warning light may illuminate. Pull your car over to a safe place and stop the engine.
- Restart the engine. If the ABS warning light is off, then your ABS system is normal. Otherwise, you may have a problem with the ABS. Contact an authorized Kia dealer as soon as possible.

*** NOTICE**

When you jump start your vehicle because of a drained battery, the engine may not run as smoothly and the ABS warning light may turn on at the same time. This happens because of the low battery voltage. It does not mean your ABS is malfunctioning.

- Do not pump your brakes!
- Have the battery recharged before driving the vehicle.

امداد خودرو فارما

تلفن شبانه روزی: ۰۲۱-۸۸۸۶۲۰۸۵

FarmaSOS.com

1

2

3

4

5

6

7

8

9

STEERING WHEEL

Power steering

Power Steering uses energy from the engine to assist you in steering the vehicle. If the engine is off or if the power steering system becomes inoperative, the vehicle may still be steered, but it will require increased steering effort.

Should you notice any change in the effort required to steer during normal vehicle operation, have the power steering checked by an Authorized Kia Dealer.

* NOTICE

- Never hold the steering wheel against a stop (extreme right or left turn) for more than 5 seconds with the engine running. Holding the steering wheel for more than 5 seconds in either position may cause damage to the power steering pump.
- If the power steering drive belt breaks or if the power steering pump malfunctions, the steering effort will greatly increase.

* NOTICE

If the vehicle is parked for extended periods outside in cold weather (below -10 °C/14 °F), the power steering may require increased effort when the engine is first started. This is caused by increased fluid viscosity due to the cold weather and does not indicate a malfunction.

When this happens, increase the engine RPM by depressing accelerator until the RPM reaches 1,500 rpm then release or let the engine idle for two or three minutes to warm up the fluid.

1

2

3

4

5

6

7

8

9

تلفن شبانه روزی: ۰۲۱-۸۸۸۶۲۰۸۵

FarmaSOS.com

Tilt steering (if equipped)

A tilt steering wheel allows you to adjust the steering wheel before you drive. You can also raise it to the highest level to give your legs more room when you exit and enter the vehicle.

The steering wheel should be positioned so that it is comfortable for you to drive, while permitting you to see the instrument panel warning lights and gauges.

⚠ WARNING

- **Never adjust the angle of steering wheel while driving. You may lose your steering control and cause severe personal injury or accidents.**
- **After adjusting, push the steering wheel both up and down to be certain it is locked in position.**

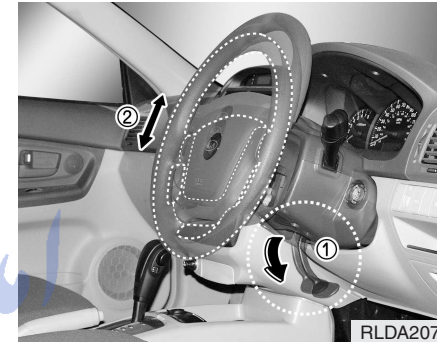

To change the steering wheel angle, pull down (①) the lock release lever, adjust the steering wheel to the desired angle (②), then pull up the lock-release lever to lock the steering wheel in place.

Be sure to adjust the steering wheel to the desired position before driving.

- 1
- 2
- 3
- 4
- 5
- 6
- 7
- 8
- 9

شبانہ روزی: ۰۲۱-۸۸۸۶۲۰۸۵

FarmaSOS.com

- 1
- 2
- 3
- 4
- 5
- 6
- 7
- 8
- 9



CAUTION

- To sound the horn, press the area indicated by the horn symbol on your steering wheel (see illustration). The horn will operate only when this area is pressed.
- Do not strike the horn severely to operate it, or hit it with your fist. Do not press on the horn with a sharp-pointed object.

Horn

- 5 To sound the horn, press the horn symbol on your steering wheel.
- 6 Check the horn regularly to be sure it operates properly.

تلفن شبانه روزی: ۰۸۵-۸۸۸۶۲-۲۱

FarmaSOS.com

CRUISE CONTROL SYSTEM (IF EQUIPPED)

The cruise control system allows you to program the vehicle to maintain a constant speed without resting your foot on the accelerator pedal.

With cruise control, you can set and automatically maintain any speed of between 40 km/h (24 mph) and 163 km/h (102 mph).

⚠ WARNING - Cruise control

Do not use the cruise control feature under the following conditions:

- Heavy or unsteady traffic
- Slippery or winding roads
- Situations that involve varying speeds



To set cruise control speed:

1. Push the CRUISE ON/OFF button on the steering wheel, to turn the system on. The CRUISE indicator light in the instrument cluster will illuminate.

2. Accelerate to the desired speed, which must be more than 40 km/h (24 mph) and less than 163 km/h (102 mph).

⚠ WARNING

If the cruise control is left on, (CRUISE indicator light in the instrument cluster illuminated) the cruise control can be switched on accidentally. Keep the cruise control system off (CRUISE indicator light OFF) when cruise control is not in use.

- 1
- 2
- 3
- 4
- 5
- 6
- 7
- 8
- 9

1

2

3

4

5

6

7

8

9



3. Push down the SET/COAST switch, and release it at the speed you want. The "SET" indicator light in the instrument cluster will illuminate. Release the accelerator at the same time. The desired speed will automatically be maintained.

The SET function cannot be activated until approximately 2 seconds after the CRUISE ON-OFF button has been engaged.

On a steep grade, the vehicle may momentarily slow down while going downhill.



To cancel cruise control, do one of the following:

- Press the brake pedal.
- Press the clutch pedal with a manual transaxle or shift into N (Neutral) with an automatic transaxle.
- Pull the CANCEL switch.

Each of these actions will cancel cruise control operation (the "SET" indicator light in the instrument cluster will go OFF), but it will not turn the system off. If you wish to resume cruise control operation, push up the RES/ACC switch located on your steering wheel. You will return to your previously preset speed.

To turn cruise control off, do one of the following:

- Push the CRUISE ON-OFF button (the CRUISE indicator light in the instrument cluster will go OFF).
- Turn the ignition off.

Both of these actions cancel cruise control operation. If you want to resume cruise control operation, repeat the steps provided in "To Set Cruise Control Speed" on the previous page.



To increase cruise control set speed:

Follow either of these procedures:

- Push up the RES/ACC switch and hold it. Your vehicle will accelerate. Release the switch at the speed you want.

- Push up the RES/ACC switch and release it immediately. The cruising speed will increase 1.6 km/h (1 mph) by one touch and will be memorized to the reset speed.

- 1
- 2
- 3
- 4
- 5
- 6
- 7
- 8
- 9

To temporarily accelerate with the cruise control on

1

If you want to speed up temporarily when the cruise control is on, depress the accelerator pedal. Increased speed will not interfere with cruise control operation or change the set speed.

2

3

To return to the set speed, take your foot off the accelerator.

4

5

6

7

8

9



- Push down the SET/COAST switch and release it immediately. The cruising speed will decrease 1.6 km/h (1 mph) by one touch and will be memorized to the reset speed.

To decrease the cruising speed:

Follow either of these procedures:

- Push down the SET/COAST switch and hold it. Your vehicle will gradually slow down. Release the switch at the speed you want to maintain.

FarmaSOS.com



It will not resume, however, if the vehicle speed has dropped below 40km/h (24 mph).

To resume cruising speed at more than 40 km/h (24 mph):

If any method other than the CRUISE ON-OFF switch was used to cancel cruising speed and the system is still activated, the most recent set speed will automatically resume when the RES/ACC switch is pushed up.

FarmaSOS.com

تلفن شبانه روزی: ۰۸۵-۸۸۸۶۲-۲۱

امداد خودرو فارس

- 1
- 2
- 3
- 4
- 5
- 6
- 7
- 8
- 9

TRACTION CONTROL SYSTEM (IF EQUIPPED)

- 1
- 2
- 3
- 4
- 5
- 6
- 7
- 8
- 9



The Traction Control System (TCS) helps the vehicle accelerate on slippery road surfaces by preventing the drive wheels from spinning excessively. It also provides improved driving force and steering.

TCS operation

TCS ON condition



- When the ignition is turned ON, TCS and TCS OFF indicator light illuminate for approximately 3 seconds, then TCS is turned on.
- Press the TCS button to turn TCS off. (TCS OFF indicator will illuminate). To turn the TCS on, press the TCS button (TCS OFF indicator light will go off).
- When starting the engine, you may hear a slight ticking sound. This is the TCS performing an automatic system self-check and does not indicate a problem.

When operating



When the TCS is in operation, TCS indicator light blinks.

- When the traction control system is operating properly, you can feel a slight pulsation in the vehicle. This is only the effect of brake control and indicates nothing unusual.
- When moving out of mud or driving on a slippery road, pressing the accelerator pedal may not cause the engine rpm (revolutions per minute) to increase.

FarmaSOS.com

TCS operation off

TCS OFF state

**TCS
OFF**

- To cancel TCS operation, press the TCS button (TCS OFF indicator light illuminates).
- If the ignition switch is turned to LOCK position when TCS is off, TCS remains off. Upon restarting the engine, the TCS will automatically turn on again.

■ TCS indicator light (blinks)

TCS

■ TCS OFF indicator light (comes on)

**TCS
OFF**

Indicator light

When ignition switch is turned to ON, the indicator light illuminates, then goes off if TCS system is operating normally.

The TCS indicator light blinks whenever TCS is operating.

TCS OFF indicator light comes on when either the TCS is turned off with the button, or TCS fails to operate when turned on.

⚠ WARNING

The Traction Control System is only a driving aid; use precautions for safe driving by slowing down on curved, snowy, or icy roads. Drive slowly and don't attempt to accelerate whenever the TCS indicator light is blinking, or when the road surface is slippery.

1

2

3

4

5

6

7

8

9

TCS OFF usage

When driving

- 1 • It's a good idea to keep the TCS turned on for daily driving whenever possible.
- 2 • To turn TCS off while driving, press the TCS button while driving on a flat road surface.
- 3 Never press TCS button while TCS is operating (TCS indicator light blinks).
- 4 If TCS is turned off while TCS is operating, the vehicle may slip out of control.
- 5
- 6
- 7
- 8
- 9

* NOTICE

- When measuring the vehicle speed with a Chassis dynamometer, make sure the TCS is turned off (TCS OFF light illuminated). If the TCS is left on, it may prevent the vehicle speed from increasing, and cause a false diagnosis of a faulty speedometer.
- Turning the TCS off does not affect ABS or brake system operation.

⚠ WARNING

Never press the TCS button while TCS is operating.
If the TCS is turned off while TCS is operating, the vehicle may slip out of control.
To turn TCS off while driving, press the TCS button while driving on a flat road surface.

تلفن شبانه روزی: ۰۲۱-۸۸۸۶۲۰۸۵

FarmaSOS.com

INSTRUMENT CLUSTER

■ Gasoline (Type A)



■ Diesel (Type A)



■ Gasoline (Type B)

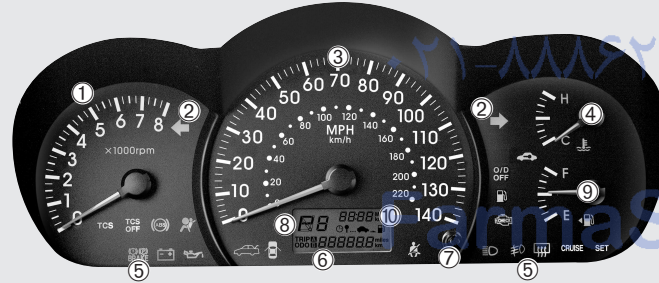

■ Diesel (Type B)



- 1. Tachometer
- 2. Turn signal indicators
- 3. Speedometer

- 4. Engine temperature gauge
- 5. Warning and indicator lights
- 6. Odometer / Tripmeter
- 7. Tripmeter mode/reset button

- 8. Shift position indicator
(Automatic transaxle only)
- 9. Fuel gauge
- 10. Trip computer (if equipped)

1LDE2090/1LDE2090A/1LDE2090B/1LDE2090C



GAUGES

Speedometer

The speedometer indicates the forward speed of the vehicle.

1

Odometer/Tripmeter

You can choose the odometer, tripmeter A and tripmeter B by pressing the tripmeter mode button.

2

3

Odometer

The odometer indicates the total distance the vehicle has been driven.

4

5

Tripmeter

TRIP A: Tripmeter A

TRIP B: Tripmeter B

6

7

The tripmeter indicates the distance of individual trips selected by the driver. Tripmeter A and B can be reset to 0 by pressing the reset button for 1 second or more, and then releasing.

8

9



* NOTICE

Do not operate the engine within the tachometer's RED ZONE. This may cause severe engine damage.

Tachometer

The tachometer indicates the approximate number of engine revolutions per minute (rpm).

Use the tachometer to select the correct shift points and to prevent lugging and/or over-revving the engine.

The tachometer pointer may move slightly when the ignition switch is in ACC or ON position with the engine OFF. This movement is normal and will not affect the accuracy of the tachometer once the engine is running.

Engine temperature gauge

This gauge shows the temperature of the engine coolant when the ignition switch is ON.

Do not continue driving with an overheated engine. If your vehicle overheats, refer to “Overheating” in the Index.

* NOTICE

If the gauge pointer moves beyond the normal range area toward the “H” position, it indicates overheating that may damage the engine.

Fuel gauge

The fuel gauge indicates the approximate amount of fuel remaining in the fuel tank.

Fuel tank capacity - 55 litres.

The fuel gauge is supplemented by a low fuel warning light, which will illuminate when the fuel level has dropped to about 8.5 litres.

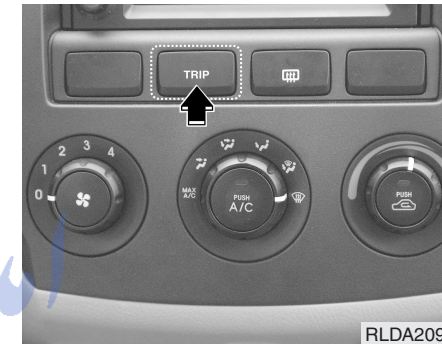

Trip computer (if equipped)

Trip computer is a microcomputer-controlled driver information gauge that displays information related to driving, such as estimated distance to empty, average speed and driving time on the LCD.

- 1
- 2
- 3
- 4
- 5
- 6
- 7
- 8
- 9

- 1
- 2
- 3
- 4
- 5
- 6
- 7
- 8
- 9

Mode

Push "TRIP" to select distance to empty, average speed and driving time for the driving information. Each push of the button changes the display as follows;

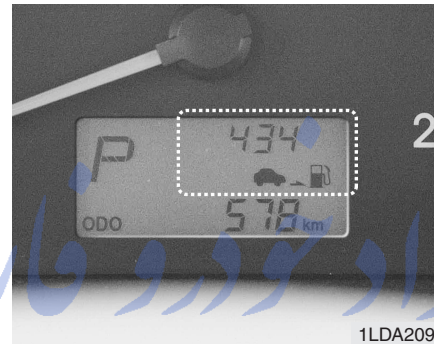
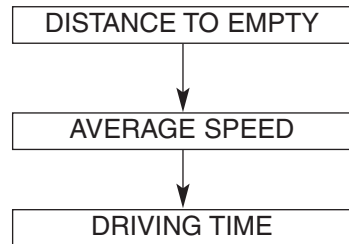

Distance to empty

This mode indicates the estimated distance to empty from the current fuel in the fuel tank. When the remaining distance is below 50 km (30 miles), a blinking "--." symbol will be displayed.

Trip computer recognizes only the amount of fuel consumed to the engine. Therefore if the vehicle happens to abnormal oil leakage, the trip computer fails to sense causing the amount of fuel more than it really is.

*** NOTICE**

- If the vehicle is not on level ground or the battery power has been interrupted, the "DISTANCE TO EMPTY" function may not operate correctly.
The trip computer may not register additional fuel if less than 6 litres of fuel are added to the vehicle.
- Trip computer provides a driver with supplemental information about the current operating status of your vehicle. So the estimated distance to empty can be changed according to operating status of your vehicle, average fuel consumption and previously driving style. Therefore the values approved or displayed on LCD for the first time can be different with your vehicle's.
- The figure of distance to empty is estimated driving distance, so it can be different from the driving distance really is.

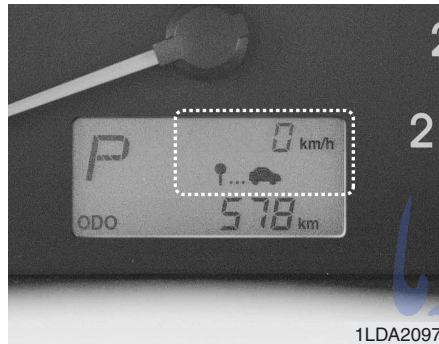

1LDA2097

Average speed

This mode indicates the average speed from the starting of the vehicle to the ignition key "OFF". When the ignition key is "OFF", it will initialize to 0 km/h (0 mph).

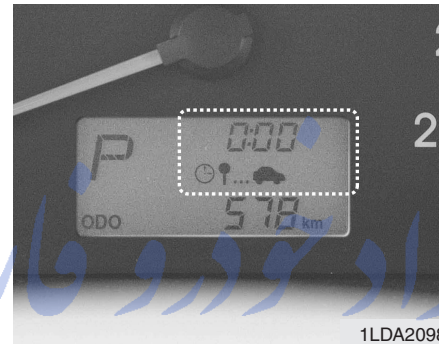

1LDA2098

Driving time

This mode indicates the total time from the starting of the vehicle to the ignition key "OFF" after resetting. When the "TRIP" switch is pushed, it will initialize to 0:00.

Reset

Push "TRIP" for more than 1 second to initialize the displayed information such as average speed and driving time.



RLDA2117A

Instrument panel illumination (if equipped)

When the vehicle's parking lights or headlights are on, rotate the illumination control knob to adjust the instrument panel illumination intensity.

- 1
- 2
- 3
- 4
- 5
- 6
- 7
- 8
- 9

WARNINGS AND INDICATORS

Warning lights / audible indicators

1

Checking operation

All warning lights are checked by turning the ignition switch ON (do not start the engine). Any light that does not illuminate should be checked by an Authorized Kia Dealer.

2

3

After starting the engine, check to make sure that all warning lights are off. If any are still on, this indicates a situation that needs attention. When releasing the parking brake, the brake system warning light should go off. The fuel warning light will stay on if the fuel level is low.

5

6

7

8

9

Anti-lock brake system (ABS) warning light (if equipped)



This light illuminates if the key is turned to ON and goes off in approximately 3 seconds if the system is operating normally.

If the light stays on, you may have a problem with your ABS system. Contact an authorized Kia dealer as soon as possible.

Electronic brake force distribution (EBD) system warning light (if equipped)



If two warning lights illuminate at the same time while driving, your vehicle has a problem with ABS and EBD system.



In this case, your ABS system and regular brake system may not work normally. Have the vehicle checked by an Authorized Kia Dealer as soon as possible.

⚠ WARNING

If the both ABS and Brake warning lights are ON and stay ON, your vehicle's brake system will not work normally. So you may experience an unexpected and dangerous situation during sudden braking. In this case, avoid high speed driving and abrupt braking. Have your vehicle checked by Authorized Kia Dealer as soon as possible.

Engine oil pressure warning



This warning light indicates the engine oil pressure is low.

If the warning light illuminates while driving:

1. Drive safely to the side of the road and stop.
2. With the engine off, check the engine oil level. If the level is low, add oil as required.

If the warning light remains on after adding oil or if oil is not available, call an Authorized Kia Dealer.

*** NOTICE**

If the engine is not stopped immediately, severe damage could result.

Charging system warning



This warning light indicates a malfunction of either the generator or electrical charging system.

If the warning light comes on while the vehicle is in motion:

1. Drive to the nearest safe location.
2. With the engine off, check the generator drive belt for looseness or breakage.
3. If the belt is adjusted properly, a problem exists somewhere in the electrical charging system. Have an Authorized Kia Dealer correct the problem as soon as possible.

Safety belt warning



As a reminder to the driver and passenger, safety belt warning light will blink for approximately 6 seconds each time you turn the ignition switch ON.

If the driver's lap/shoulder belt is not fastened when the key is turned ON or if it is unfastened after the key is ON, the safety belt warning light blinks for 6 seconds. If the system does not operate as described, see an Authorized Kia Dealer for assistance.

- 1
- 2
- 3
- 4
- 5
- 6
- 7
- 8
- 9

- 1
- 2
- 3
- 4
- 5
- 6
- 7
- 8
- 9

Rear window defroster indicator (if equipped)

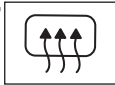

This light comes on when the rear defroster switch is depressed to remove the frost on the rear glass. Press the switch again to shut off the defroster when the frost is removed. The rear window defroster will automatically turn off after 20 minutes. It will also turn off whenever you remove the ignition key.

Shift pattern indicators (if equipped)

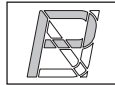

The individual indicators illuminate to show the automatic transaxle shift lever selection.

O/D OFF Indicator (if equipped)



This indicator comes on when the O/D system is deactivated.

Immobilizer indicator (if equipped)



This light illuminates when the immobilizer key is inserted and turned to the ON position to start the engine. If this light turns off or blinks when the ignition switch is in the ON position before starting the engine, have the system checked by an authorized Kia Dealer.

تلفن شبانه روزی: ۰۲۱-۸۸۸۶۲۰۸۵

FarmaSOS.com

Parking brake & brake fluid warning



Parking brake warning

This light is illuminated when the parking brake is applied with the ignition switch in the START or ON position. The warning light should go off when the parking brake is released.

Low brake fluid level warning

If the warning light remains on, it may indicate that the brake fluid level in the reservoir is low.

If the warning light remains on:

1. Drive carefully to the nearest safe location and stop your vehicle.
2. With the engine stopped, check the brake fluid level immediately and add fluid as required. Then check all brake components for fluid leaks.
3. Do not drive the vehicle if leaks are found, the warning light remains on or the brakes do not operate properly. Have it towed to any Authorized Kia Dealer for a brake system inspection and necessary repairs.

To check bulb operation, check whether the parking brake and brake fluid warning light illuminates when the ignition switch is in the ON position.







Low brake vacuum pressure warning (for diesel, if equipped)

If the brake warning light remains on after adding brake fluid and the brake pedal becomes heavier or harder, it may indicate that the brake vacuum pump has any problem. Therefore you should avoid high speed driving or sudden stop, and you should depress the brake pedal deeper and harder than usual in braking. Make sure to have the brake system checked and repaired by an authorized Kia dealer.

⚠ WARNING

Driving the vehicle with a warning light on is dangerous. If the brake warning light remains on, have the brakes checked and repaired immediately by an authorized Kia Dealer.

- 1
- 2
- 3
- 4
- 5
- 6
- 7
- 8
- 9

- | | | | | | | |
|----------|---|---|---|---|--|---|
| 1 | Trunk lid open warning (if equipped) |  | Headlight high beam indicator |  | Malfunction indicator (if equipped) |  |
| 2 | This warning light activates when the trunk is not closed securely. | | | | | |
| 3 | Low fuel level warning |  | | | | |
| 4 | This warning light indicates the fuel tank is nearly empty. The warning light will come on when the fuel level has dropped to about 8.5 litres. Refuel as soon as possible. | | Front fog light indicator (if equipped) |  | | |
| 5 | | | This light comes on when the front fog lights are ON. | | | |
| 6 | Door ajar warning |  | | | | |
| 7 | | | | | | |
| 8 | This warning light illuminates when a door is not closed securely with the ignition in any position. | | | | | |
| 9 | | | | | | |

CAUTION

- *Prolonged driving with the Emission Control System Malfunction Indicator Light (MIL) illuminated may cause damage to the emission control systems which could affect drivability and/or fuel economy.*
- *If the Emission Control System Malfunction Indicator Light (MIL) begins to flash ON and OFF, potential catalytic converter damage is possible which could result in loss of engine power. Have the Engine Control System inspected as soon as possible by an authorized Kia Dealer.*

Air bag warning (if equipped)



This warning light will blink or illuminate for approximately 6 seconds each time you turn the ignition switch to the ON position.

If this indicator does not go out, or if it illuminates while the vehicle is being driven, see an authorized Kia Dealer for immediate service.

Auto cruise indicator (if equipped)

CRUISE indicator



The indicator light illuminates when the cruise control system is enabled.

SET indicator



The indicator light illuminates when the cruise function switch (SET/COAST or RES/ACC) is ON.

- 1
- 2
- 3
- 4
- 5
- 6
- 7
- 8
- 9

- 1
- 2
- 3
- 4
- 5
- 6
- 7
- 8
- 9

TCS indicator (Traction Control System) (if equipped)



The TCS indicator will illuminate when the ignition switch is turned ON, but should go off after approximately 3 seconds. When the TCS is on, it monitors the driving conditions and under normal driving conditions, the TCS light will remain off. When a slippery or low traction condition is encountered, the TCS will operate, and the TCS indicator will blink to indicate the TCS is operating.

TCS OFF indicator (if equipped)



The TCS OFF indicator will illuminate when the ignition switch is turned ON, but should go off after approximately 3 seconds. To switch to TCS OFF mode, press the TCS button. The TCS OFF indicator will illuminate indicating the TCS is deactivated. If this indicator stays on in the TCS ON mode, the TCS may have a malfunction. Take your car to the authorized Kia dealer and have the system checked.

Glow indicator (diesel engine only)



This light is turned on during warm-up and turned off after it.

*** NOTICE**

If the glow indicator continues to illuminate after the engine has warmed up or while driving, check the system by an Authorized Kia Dealer or other competent repair shop as soon as possible.

تلفن شبانه روزی: ۰۲۱-۸۸۸۶۲۰۸۵

FarmaSOS.com

Sedimentor level warning (diesel engine only)



The light comes on if water in the sedimentor is accumulated more than normal. Drain water if the light is turned on. Driving with the light on may damage the engine.

Safety belt warning chime

If the driver's seat belt is not fastened when the ignition key is turned "ON" or if it is disconnected after the key is ON, the safety belt warning chime will sound for approximately 6 seconds.

Door ajar warning chime (if equipped)

If a door is opened with the ignition switch ON, the warning chime will sound.

Key reminder warning chime

If the driver's door is opened and the ignition key is left in the ignition switch in the LOCK or ACC position, the key reminder warning chime will sound. This is to prevent you from locking your keys in the vehicle.

Overspeed warning chime (if equipped)

If you drive with the speed of 120 km/h or more, the overspeed warning chime will sound. This is to prevent you from driving your vehicle with overspeed.

1

2

3

4

5

6

7

8

9

تلفن شبانه روزی: ۰۲۱-۸۸۸۶۲۰۸۵

FarmaSOS.com

LIGHTING

Battery saver function

- The purpose of this feature is to prevent the battery from being discharged. The system automatically turns off the small light when the driver removes the ignition key and opens the driver-side door.
- With this feature, the parklight will be turned off automatically if the driver parks on the side of road at night.

If necessary, to keep the lights on when the ignition key is removed, perform the following :

- 1) Open the driver-side door.
- 2) Turn the parklights OFF and ON again using the light switch on the steering column.



Lighting control

The light switch has a Headlight and a Parklight position.

To operate the lights, turn the knob at the end of the control lever to one of the following positions:

- ① OFF position
- ② Parklight position
- ③ Headlight position
- ④ Auto light position (if equipped)



Parklight position (پارک‌لایت)

When the light switch is in the parklight position (1st position), the tail, position, license and instrument panel lights are ON.

1

2

3

4

5

6

7

8

9

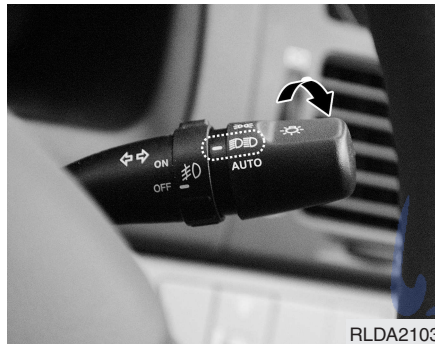

RLDA2103

Headlight position (2nd)

When the light switch is in the headlight position (2nd position) the head, tail, position, license and instrument panel lights are ON.

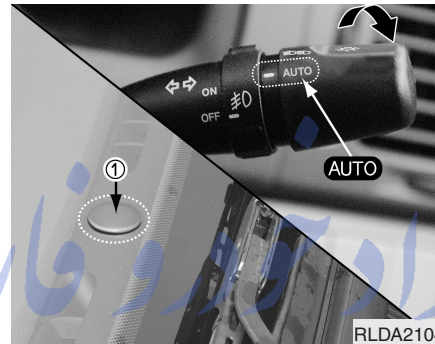

RLDA2104

Auto light position (if equipped)

When the light switch is in the AUTO light position, the taillights and headlights will be turned ON or OFF automatically depending on the amount of light outside the vehicle.

*** NOTICE**

- Never place anything over sensor (1) located on the instrument panel, this will ensure better auto-light system control.
- Don't clean the sensor using a window cleaner, the cleanser may leave a light film which could interfere with sensor operation.
- If your vehicle has window tint or other types of coating on the front windshield, the Auto light system may not work properly.

- 1
- 2
- 3
- 4
- 5
- 6
- 7
- 8
- 9

1

2

3

4



High - beam operation

To turn on the high beam headlights, push the lever away from you. Pull it back for low beams.

The high-beam indicator will light when the headlight high beams are switched on.

To prevent the battery from being discharged, do not leave the lights on for a prolonged time while the engine is not running.

5

6

7

8

9



Flashing headlights

To flash the headlights, pull the lever towards you. It will return to the normal (low-beam) position when released. The headlight switch does not need to be on to use this flashing feature.

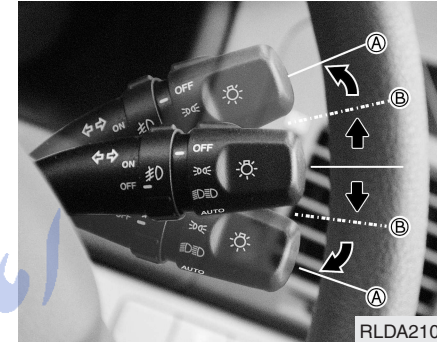

Turn signals (A)

The ignition switch must be on for the turn signals to function. To turn on the turn signals, move the lever up or down. Green arrow indicators on the instrument panel indicate which turn signal is operating. They will self-cancel after a turn is completed. If the indicator continues to flash after a turn, manually return the lever to the OFF position.

Lane change signals (B)

To signal a lane change, move the turn signal lever slightly and hold it in position. The lever will return to the OFF position when released.

If an indicator stays on and does not flash or if it flashes abnormally, one of the turn signal bulbs may be burned out and will require replacement.

*** NOTICE**

If an indicator flash is abnormally quick or slow, bulb may be burned out or have a poor electrical connection in the circuit.



Front fog light (if equipped)

Fog lights are used to provide improved visibility and avoid accidents when visibility is poor due to fog, rain or snow etc. The fog lights will turn on when fog light switch (1) is turned to ON (2) after the headlight switch is turned on.

To turn off the fog lights, turn the switch to OFF.

*** NOTICE**

When in operation, the fog lights consume large amounts of vehicle electrical power. Only use the fog lights when visibility is poor or unnecessary battery and generator drain could occur.

- 1
- 2
- 3
- 4
- 5
- 6
- 7
- 8
- 9

Daytime running light (if equipped)

- 1
- 2
- 3
- 4
- 5
- 6
- 7
- 8
- 9

Daytime Running Lights (DRL) can make it easier for others to see the front of your vehicle during the day. DRL can be helpful in many different driving conditions, and it is especially helpful after dawn and before sunset.

The DRL system will make your low-beam headlights turn OFF when:

1. The headlight switch is ON.
2. The parklight switch is ON.
3. Engine stops.



Headlight leveling device (if equipped)

This manual system is provided to avoid obstructing oncoming drivers vision with your headlights. The headlight level can be adjusted by rotating the thumb-wheel switch in accordance with the following settings.

Switch setting:

4 Door

Position	Loading on		
	Front seats	Rear seats	Rear Trunk
0	1 driver	-	-
	2 persons	-	-
1	2 persons	3 persons	-
2	2 persons	3 persons	140 kg
3	1 driver	-	410 kg

5 Door

Position	Loading on		
	Front seats	Rear seats	Rear luggage room
0	1 driver	-	-
	2 persons	-	-
1	2 persons	3 persons	-
2	2 persons	3 persons	120 kg
3	1 driver	-	380 kg

**Rear fog light (if equipped)**

To turn the rear fog lights on, turn the headlight switch to the headlight on position and press the rear fog light switch (light on switch will illuminate).

The rear fog lights turn on when the rear fog switch is pressed after the front fog switch is turned to ON and the headlight switch to the parklight position. (if equipped)

To turn the rear fog lights off, press the rear fog light switch again or turn the headlight switch to the OFF position.

1

2

3

4

5

6

7

8

9

WIPERS AND WASHERS

- 1
- 2
- 3
- 4
- 5
- 6
- 7
- 8
- 9

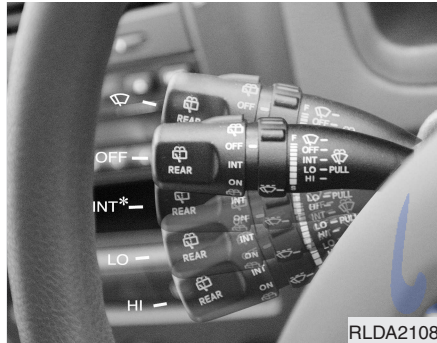

LO : Normal wiper speed

HI : Fast wiper speed

 : For a single wiping cycle, push the lever forward and release it with the lever in the OFF position. The wipers will operate continuously if the lever is pushed upward and held.

* NOTICE

If there is heavy accumulation of snow or ice on the windshield, defrost the windshield for about 10 minutes, or until the snow and/or ice is removed before using the windshield wipers to ensure proper operation.

Windshield wipers

Operates as follows when the ignition switch is turned ON.

OFF : Wiper is not in operation

INT : Wiper operates intermittently at the same wiping intervals. Use this mode in a light rain or mist. To vary the speed setting, turn the speed control knob(①). (S : slow operation, F: fast operation)

آمداد خودرو فارس
تلفن شبانه روزی: ۰۲۱-۸۸۸۶۲۰۸۵
ArmaSOS.com



RLDA2109

Variable intermittent wipers

Set the lever to the INT position and choose the desired wiper interval by turning the ring(①).



RLDA2110

One - touch wiper

For a single wiping cycle, push the lever upward and release it with the lever in the OFF position.

The wipers will operate continuously if the lever is pushed upward and held.

* NOTICE

- To prevent possible damage to the wipers or windshield, do not operate the wipers when the windshield is dry.
- To prevent damage to the wiper blades, do not use gasoline, kerosene, paint thinner, or other solvents on or near them.
- To prevent damage to the wiper arms and other components, do not attempt to move the wipers manually.

- 1
- 2
- 3
- 4
- 5
- 6
- 7
- 8
- 9

- 1
- 2
- 3
- 4**
- 5
- 6
- 7
- 8
- 9



Windshield washers

In the OFF position, pull the lever gently toward you to spray washer fluid on the windshield and to run the wipers 2-3 cycles.

Use this function when the windshield is dirty.

The spray and wiper operation will continue until you release the lever.

If the washer does not work, check the washer fluid level. If the fluid level is not sufficient, you will need to add appropriate non-abrasive windshield washer fluid to the washer reservoir.

The reservoir filler neck is located in the front of the engine compartment on the passenger side.

* NOTICE

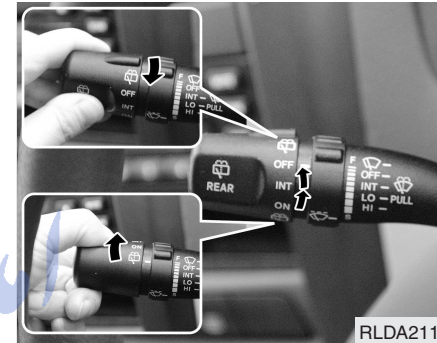

To prevent possible damage to the washer pump, do not operate the washer when the fluid reservoir is empty.

⚠ WARNING
Do not use the washer in freezing temperatures without 1st warming the windshield with the defrosters; the washer solution could freeze on contact with the windshield and obscure your vision.



Rear window wiper and washer switch (if equipped)

The rear window wiper and washer switch is located at the end of the wiper and washer switch lever. Turn the switch to desired position to operate the rear wiper and washer.

-  - Spraying washer fluid and wiping
- INT - Intermittent wiper operation
- ON - Normal wiper operation
-  - Spraying washer fluid and wiping

DEFROSTER

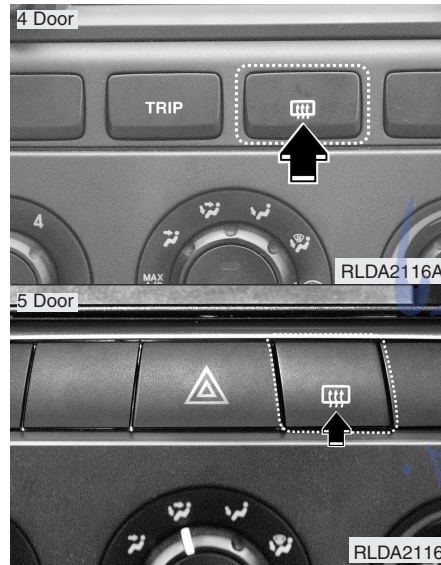

The defroster heats the window to remove frost, fog and thin ice from the interior and exterior of the rear window, while engine is running.

* NOTICE

- To prevent damage to the conductors bonded to the inside surface of the rear window, never use sharp instruments or window cleaners containing abrasives to clean the window.
- To prevent the battery from being discharged, operate the defroster only while the engine is running.
- If you want to defrost and defog on the front windshield, refer to “Windshield Defrosting and Defogging” in this section.

To activate the rear window defroster, press the rear window defroster button located in the centre console switch panel. The indicator in the instrument cluster illuminates when the defroster is ON.

If your vehicle is equipped with the outside mirror defroster, it will be operating at the same time when you operate the rear window defroster.

If there is heavy accumulation of snow on the rear window, brush it off before operating the rear defroster.

The rear window defroster automatically turns off after 20 minutes or when the ignition switch is turned off. To turn off the defroster, press the rear window defroster button again.



parmaSOS.com

HAZARD WARNING FLASHER

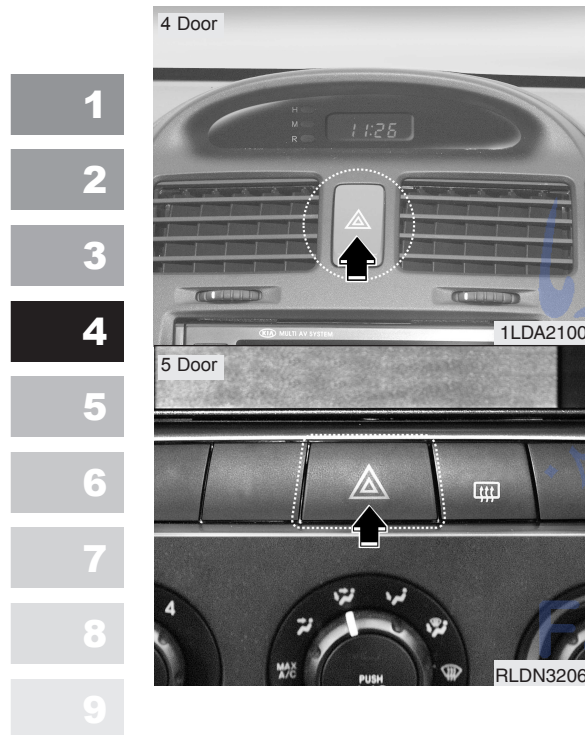

The hazard warning flasher causes the rear tail lights and front turn signal lights to flash on and off, which serves as a warning to other drivers to exercise caution when approaching or passing your vehicle.

To activate the flasher, depress the hazard warning flasher switch. This switch operates in any ignition switch position.

To turn the flashers off, depress the switch again.

تلفن شبانه روزی: ۰۸۵-۸۸۸۶۲-۲۱

FarmaSOS.com

MANUAL CLIMATE CONTROL SYSTEM (IF EQUIPPED)



- 1. Fan speed control knob
- 2. Mode selection knob
- 3. Temperature control knob

- 4. Air intake control button
- 5. Air conditioning button (if equipped)



FarmaSOS.com

1LDA2120

- 1
- 2
- 3
- 4**
- 5
- 6
- 7
- 8
- 9

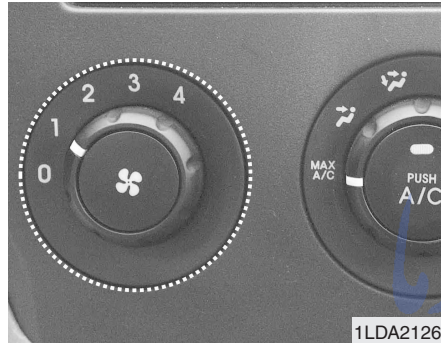

Fan speed control knob

Four (4) adjustable fan speeds are provided which increase as the number increases. The ignition switch must be in the ON position for fan operation.

- 0 - Fan off
- 1 - Low speed
- 2 - Medium speed
- 3 - High speed
- 4 - Maximum speed



Temperature control knob

The temperature control knob allows you to control the temperature of the air flowing from the ventilation system. To change the air temperature in the passenger compartment turn the knob to the right for warm and hot air or left for cooler air.

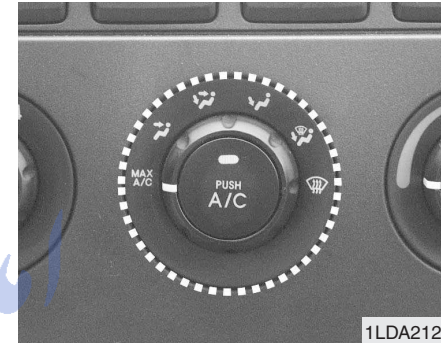

Mode selection knob

The mode selection knob controls the direction of the air flow through the ventilation system.

FarmaSOS.com

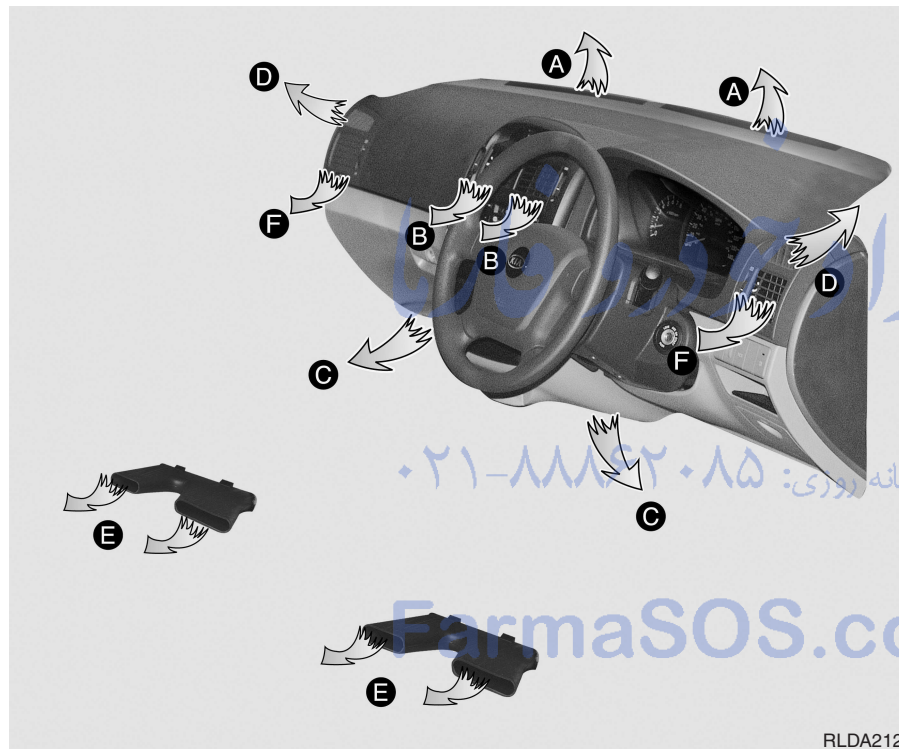

RLDA2121

MAX/ A/C position

**MAX
A/C**

When you select the MAX A/C mode while the fan speed is on, the following system settings will be made automatically;

- the air conditioning system will be turned on.
- the recirculated air position will be selected.
- the face mode will be selected.

If you select MAX A/C mode, you will not be able to cancel the A/C system operation, or change the recirculated air mode position.

Set the fan speed control knob to the desired speed and rotate the temperature control knob to the extreme left position for maximum cooling. (outlet port: (B),(F))

- 1
- 2
- 3
- 4
- 5
- 6
- 7
- 8
- 9

- 1
- 2
- 3
- 4**
- 5
- 6
- 7
- 8
- 9

Face position



Air flow is directed toward the upper body and face. Additionally, each outlet can be controlled to direct the air discharged from the outlet.
(outlet port: (B), (F))

Face - floor position



Air flow is directed towards the face and the floor. The air to the floor is warmer than the air to the face (except when the temperature control is set to the extreme cold position).
(outlet port: (B), (C), (E), (F))

Floor position



Most of the air flow is directed to the floor, with a small amount of the air being directed to the windshield and side window defroster.
(outlet port: (A), (C), (D), (E), (F))

Floor - defrost position



Most of the air flow is directed to the floor and the windshield with a small amount directed to the side window defrosters.
(outlet port: (A), (C), (D), (E), (F))

Defrost position



Most of the air flow is directed to the windshield with a small amount of air directed to the side window defrosters.
(outlet port: (A), (D), (F))

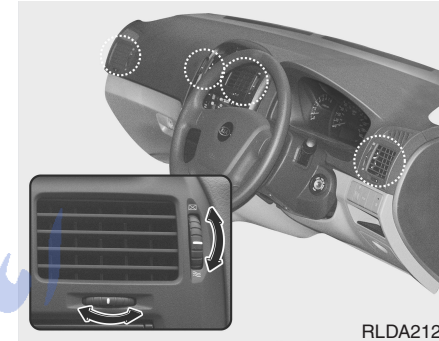

Instrument panel vents

If air flow control is not satisfactory, check the instrument panel vents. The outlet port (B), (F) can be opened or closed separately using the vertical thumbwheel. To close the vent, rotate it upward to the maximum position. To open the vent, rotate it downward.

Also, you can adjust the direction of air delivery from these vents using vertical or horizontal thumbwheels as shown.



1LDA2125

Air intake control button

This is used to select outside (fresh) air position or recirculated air position.

To change the air intake control position, push the control button.

Recirculated air position

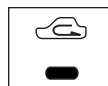

The indicator light on the button is illuminated when the recirculated air position is selected.

With the recirculated air position selected, air from passenger compartment will be drawn through the heating system and heated or cooled according to the function selected.

Outside (fresh) air position

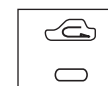

The indicator light on the button is not illuminated when the outside (fresh) air position is selected.

With the outside (fresh) air position selected, air enters the vehicle from outside and is heated or cooled according to the function selected.

اندیشه فارسی

تلفن شبانه روزی: ۰۲۱-۸۸۸۶۲۰۸۵

FarmaSOS.com

- 1
- 2
- 3
- 4
- 5
- 6
- 7
- 8
- 9

- 1
- 2
- 3
- 4
- 5
- 6
- 7
- 8
- 9

*** NOTICE**

It should be noted that prolonged operation of the heating in recirculated air position will cause fogging of the windshield and side windows and the air within the passenger compartment will become stale. In addition, prolonged use of the air conditioning with the “recirculated air position” selected, will result in excessively dry air in the passenger compartment.

⚠ WARNING

- Continued climate control system operation in the recirculated air position may allow humidity to increase inside vehicle which may fog the glass and obscure visibility.
- Do not sleep in a vehicle with air conditioning or heating system on. It may cause serious harm or death due to a drop in the oxygen level and/or body temperature.
- Continued climate control system operation in the recirculated air position can cause drowsiness or sleepiness, and loss of vehicle control. Set the air intake control to the outside (fresh) air position as much as possible while driving.

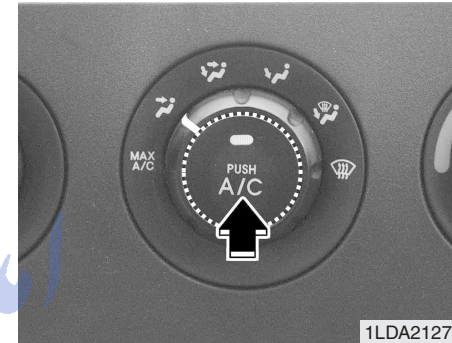

Air conditioning button (if equipped)





Push the A/C button to turn the air conditioning system on (indicator light will illuminate). Push the button again to turn the air conditioning system off.

System operation

Ventilation



1. Set the mode to the  position.
2. Set the air intake control to the outside (fresh) air position.
3. Set the temperature control to the desired position.
4. Set the fan speed control to the desired speed.

Heating

1. Set the mode to the  position.
2. Set the air intake control to the outside (fresh) air position.
3. Set the temperature control to the desired position.
4. Set the fan speed control to the desired speed.
5. If dehumidified heating is desired, turn the air conditioning system (if equipped) on.
 - If cool air is desired at face level for bi-level operation, set the mode to the  position.
 - If the windshield fogs up, set the mode to the ,  position.

Air conditioning (if equipped)

All Kia Air Conditioning Systems are filled with environmentally friendly R-134a refrigerant which is not damaging to the ozone layer.

1. Start the engine. Push the air conditioning button.
2. Set the mode to the  position.
3. Set the air intake control to the outside air or recirculated air position.
4. Set the temperature control knob to the desired position.
5. Set the fan speed control to the desired speed.
6. Adjust the fan speed control and temperature control to maintain maximum comfort.
 - If warmer air is desired at floor level for bi-level operation, set the mode to the  position and adjust the temperature control to maintain maximum comfort.

1

2

3

4

5

6

7

8

9

1

2

3

4

5

6

7

8

9

- When maximum cooling is desired, set the temperature control to the extreme left position, set the air intake control to the recirculated air position, then set the fan speed control to the highest speed.

*** NOTICE**

- When using the air conditioning system, monitor the temperature gauge closely while driving up hills or in heavy traffic when outside temperatures are high. Air conditioning system operation may cause engine overheating. Continue to use the blower fan but turn the air conditioning system off if the temperature gauge indicates engine overheating.
- When opening the windows in humid weather air conditioning may create water droplets inside the vehicle. Since excessive water droplets may cause damage to electrical equipment, air conditioning should only be run with the windows closed.

Air conditioning system operation tips

- If the vehicle has been parked in direct sunlight during hot weather, open the windows for a short time to let the hot air inside the vehicle escape.
 - To help reduce moisture inside of windows on rainy humid days, decrease the humidity inside the vehicle by operating the air conditioning system.
 - During air conditioning system operation, you may occasionally notice a slight change in engine speed at idle as the air conditioning compressor cycles on. This is a normal system operation characteristic.
 - Use the air conditioning system every month if only for a few minutes to ensure maximum system performance.
 - When using the air conditioning system, you may notice clear water dripping (or even puddling) on the ground under the passenger side of the vehicle. This is a normal system operation characteristic.
- The air conditioning system includes a function that automatically turns the air conditioning compressor off if engine coolant temperature approaches an overheating level. The air conditioning compressor operation will resume once engine coolant temperature returns to the normal range. Also, the air conditioning compressor is automatically turned off for a few seconds when the accelerator is fully depressed (wide open throttle).
 - When operating the air conditioning system use the outside (fresh) air position.
 - Operating the air conditioning system in the recirculated air position does provide maximum cooling, however, continual operation in this mode may cause the air inside the vehicle to become stale.

Checking the amount of air conditioner refrigerant and compressor lubricant

When the amount of refrigerant is low, the performance of the air conditioning is reduced. Overfilling also has a bad influence on the air conditioning system.

Therefore, if abnormal operation is found, have the system inspected by an authorized Kia dealer.

Air conditioner refrigerant and compressor lubricant

CAUTION

The air conditioning system should be serviced by an authorized Kia dealer. Improper service may cause serious injury.

*** NOTICE**

When the performance of the air conditioning system is reduced it is important that the correct type and amount of oil and refrigerant is used. Otherwise, damage to the compressor and abnormal system operation may occur.

1

2

3

4

5

6

7

8

9

FarmaSOS.com

AUTOMATIC CLIMATE CONTROL SYSTEM (IF EQUIPPED)

- 1
- 2
- 3
- 4
- 5
- 6
- 7
- 8
- 9

4 Door

5 Door

1. Front windshield defrost button
2. Temperature control knob
3. A/C display
4. Fan speed control knob
5. OFF button
6. Air quality control system button (if equipped)
7. Air intake control button
8. Air conditioning button
9. Mode selection button
10. AUTO (automatic control) button

1LDA2130/1LDA2131/1LDE2130/RLDA2131

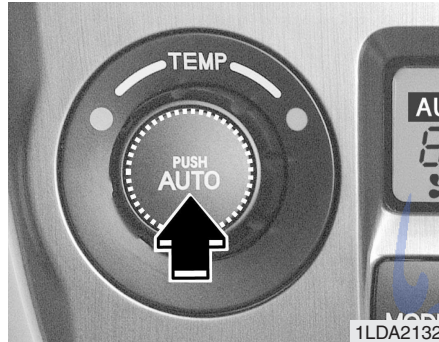

Automatic operation

The automatic climate control system is controlled by simply setting the desired temperature.

The Full Automatic Temperature Control (FATC) system automatically controls the heating and cooling system as follows;

1. Push the AUTO button. It is indicated by AUTO on the display. The modes, fan speeds, air intake and air-conditioning will be controlled automatically by temperature setting.

2. Turn the TEMP knob to set the desired temperature.

If the temperature is set to the lowest setting 17°C/62°F, the air conditioning system will operate continuously.

3. To turn the automatic operation off, press any button except temperature control button and AQS button. If you press the mode selection button, air-conditioning button, defrost button, air intake control button or fan speed button, the selected function will be controlled manually while other functions operate automatically.

Regardless of the temperature setting, when using automatic operation, the air conditioning system will automatically turn on to decrease the humidity inside the vehicle, even if the temperature is set to warm.

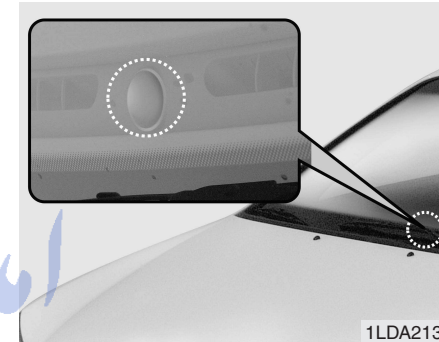

* NOTICE

Never place anything over the sensor located on the instrument panel to ensure better control of the heating and cooling system.



Manual operation

1

The heating and cooling system can be controlled manually as well by pushing buttons other than the AUTO button. In this case, the system works sequentially according to the order of buttons selected.

2

3

When pressing any button except AUTO button while automatic operation, the functions of the buttons not selected will be controlled automatically.

4

5

Press the AUTO button in order to convert to full automatic control of the system.

6

7

8

9

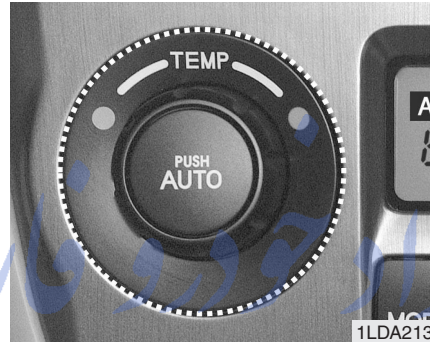

Temperature control knob

The temperature will increase to the maximum 32°C/90°F by turning the knob to the right extremely.

The temperature will decrease to the minimum 17°C/62°F by turning the knob to the left extremely.

When turning the knob, the temperature will increase or decrease by 0.5°C/1°F. When set to the lowest temperature setting, the air conditioning will operate continuously.

Temperature conversion

If the battery has been discharged or disconnected, the temperature mode will reset as Centigrade degree.

This is normal condition and you can switch the temperature mode between Centigrade to Fahrenheit as follows;

While depressing the OFF button, depress the AUTO button for 3 seconds or more. The display will change from Centigrade to Fahrenheit, or from Fahrenheit to Centigrade.

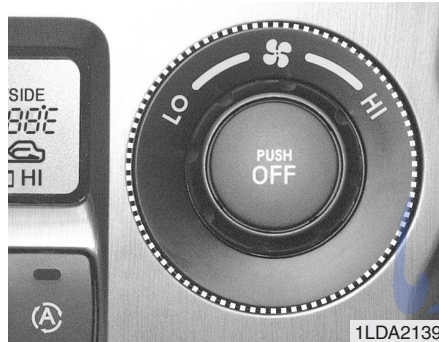

Fan speed control knob

The fan speed can be set to the desired speed by turning the fan speed control knob.

The higher the fan speed is, the more air is delivered.

Pressing the OFF button turns off the fan.



Air intake control button

This is used to select outside (fresh) air position or recirculated air position.

To change the air intake control position, push the control button.

Recirculated air position

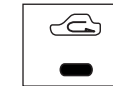

The indicator light on the button is illuminated when the recirculated air position is selected.

With the recirculated air position selected, air from passenger compartment will be drawn through the heating system and heated or cooled according to the function selected.

- 1
- 2
- 3
- 4
- 5
- 6
- 7
- 8
- 9

FarmaSOS.com

- 1
- 2
- 3
- 4**
- 5
- 6
- 7
- 8
- 9

Outside (fresh) air position

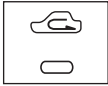

The indicator light on the button is not illuminated when the outside (fresh) air position is selected.

With the outside (fresh) air position selected, air enters the vehicle from outside and is heated or cooled according to the function selected.

*** NOTICE**

It should be noted that prolonged operation of the heating in recirculated air position will cause fogging of the windshield and side windows and the air within the passenger compartment will become stale. In addition, prolonged use of the air conditioning with the “recirculated air position” selected, will result in excessively dry air in the passenger compartment.

⚠ WARNING

- Continued climate control system operation in the recirculated air position may allow humidity to increase inside vehicle which may fog the glass and obscure visibility.
- Do not sleep in a vehicle with air conditioning or heating system on. It may cause serious harm or death due to a drop in the oxygen level and/or body temperature.
- Continued climate control system operation in the recirculated air position can cause drowsiness or sleepiness, and loss of vehicle control. Set the air intake control to the outside (fresh) air position as much as possible while driving.

تلفن شبانه روزی: ۰۲۱-۸۸۸۶۲۰۸۵

FarmaSOS.com

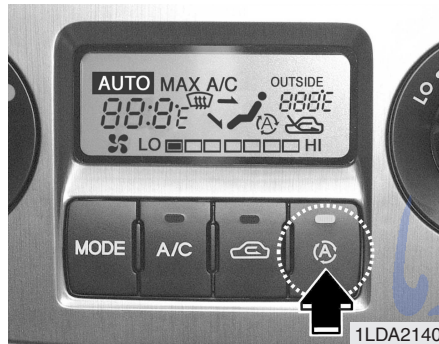

Air quality control system (if equipped)

The air inflow from outside vehicle can be automatically controlled. Press the button to activate the air quality control system.

When using AQS mode, AQS (Air Quality Control System) automatically senses outdoor air pollutants and minimizes them from entering the vehicle, however, unpleasant or foul odors that might be present may still be noticeable within the vehicle.

To deactivate the system;

- press the button again.
- press the air intake button.
- press the AUTO button.
- set the mode to the (☀️) or (🌬️) position (when the defogging logic is activated).
- set the temperature control to 17°C/62°F or 32°C/90°F position while automatic operation (the indicator light in the AUTO button is illuminate).
- Press the OFF button.

CAUTION

- *Prolonged driving with the "Air Quality Control System" ON will cause fogging inside the vehicle.*
- *To defrost inside the vehicle, press the (☀️) button or set the air intake button to the outside position.*
- *The air quality control sensor is located at the side of radiator, be careful to avoid damaging the sensor.*

1

2

3

4

5

6

7

8

9

تلفن شبانه روزی: ۰۸۵ + ۸۸۶۲ - ۱

ParmaSOS.com

- 1
- 2
- 3
- 4
- 5
- 6
- 7
- 8
- 9

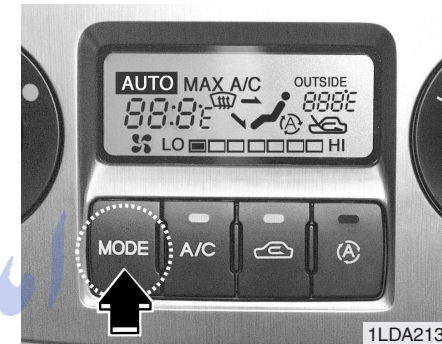
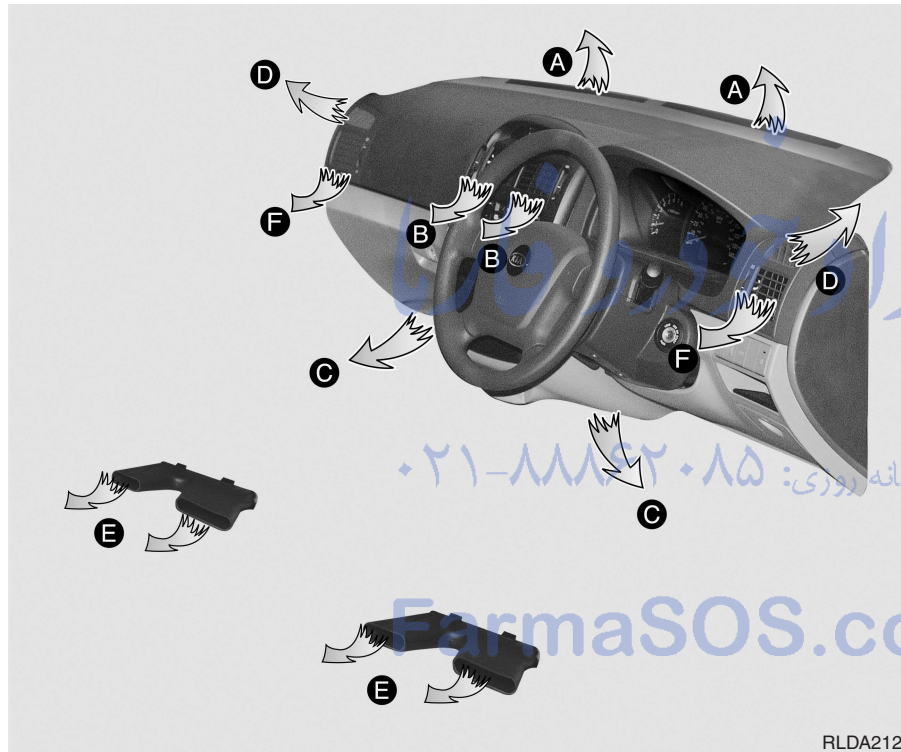

Mode selection button

The mode selection button controls the direction of the air flow through the ventilation system.

The air flow outlet port is converted as follows:



Face position



Air flow is directed toward the upper body and face. Additionally, each outlet can be controlled to direct the air discharged from the outlet. (outlet port: B, F)

Face - floor position



Air flow is directed towards the face and the floor. The air to the floor is warmer than the air to the face (except when the temperature control is set to the extreme cold position). (outlet port: B, C, E, F)

Floor position



Most of the air flow is directed to the floor, with a small amount of the air being directed to the windshield and side window defroster. (outlet port: A, C, D, E, F)

Floor - defrost position



Most of the air flow is directed to the floor and the windshield with a small amount directed to the side window defrosters. (outlet port: A, C, D, E, F)

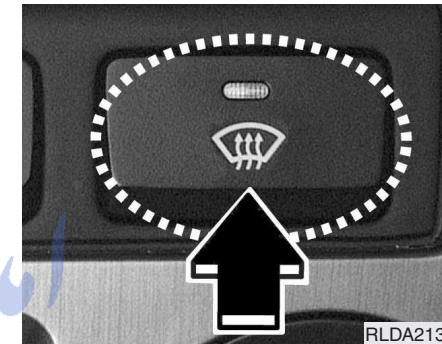

Defrost button

Most of the air flow is directed to the windshield with a small amount of air directed to the side window defrosters. (outlet port: A, D, F)

- 1
- 2
- 3
- 4
- 5
- 6
- 7
- 8
- 9

1

2

3

4



Instrument panel vents

If air flow control is not satisfactory, check the instrument panel vents. The outlet port (B, F) can be opened or closed separately using the vertical thumbwheel. To close the vent, rotate it upward to the maximum position. To open the vent, rotate it downward.

Also, you can adjust the direction of air delivery from these vents using vertical or horizontal thumbwheels as shown.

5

6

7

8

9

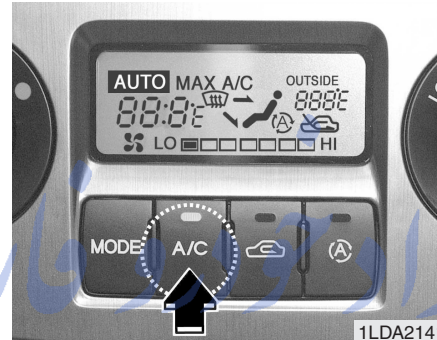

Air conditioning button

Push the A/C button to turn the air conditioning system on (indicator light will illuminate). Push the button again to turn the air conditioning system off.

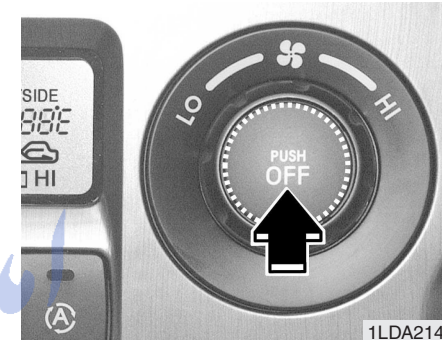

OFF button





Push the OFF button to turn off the air climate control system. However you can still operate the mode and air intake buttons as long as the ignition switch is ON.

System operation

Ventilation

1. Set the mode to the  position.
2. Set the air intake control to the outside (fresh) air position.
3. Set the temperature control to the desired position.
4. Set the fan speed control to the desired speed.

Heating

1. Set the mode to the  position.
2. Set the air intake control to the outside (fresh) air position.
3. Set the temperature control to the desired position.
4. Set the fan speed control to the desired speed.
5. If dehumidified heating is desired, turn the air conditioning system on.
 - If cool air is desired at face level for bi-level operation, set the mode to the  position.
 - If the windshield fogs up, set the mode to the ,  position.

Air conditioning

All Kia Air Conditioning Systems are filled with environmentally friendly R-134a refrigerant which is not damaging to the ozone layer.

1. Start the engine. Push the air conditioning button.
2. Set the mode to the  position.
3. Set the air intake control to the outside air or recirculated air position.
4. Set the temperature control to the desired position.
5. Set the fan speed control to the desired speed.
6. Adjust the fan speed control and temperature control to maintain maximum comfort.

1

2

3

4

5

6

7

8

9

FarmaSOS.com

1

- If warmer air is desired at floor level for bi-level operation, set the mode to the  position and adjust the temperature control to maintain maximum comfort.

2

- When maximum cooling is desired, set the temperature control to the minimum 17°C/62°F and set the air intake to the recirculated air position, then set the fan speed control to the highest speed.

3

4

5

6

7

8

9

* NOTICE

When using the air conditioning system, monitor the temperature gauge closely while driving up hills or in heavy traffic when outside temperatures are high. Air conditioning system operation may cause engine overheating. Continue to use the blower fan but turn the air conditioning system off if the temperature gauge indicates engine overheating.

Air conditioning system operation tips

- If the vehicle has been parked in direct sunlight during hot weather, open the windows for a short time to let the hot air inside the vehicle escape.
- To help reduce moisture inside of windows on rainy humid days, decrease the humidity inside the vehicle by operating the air conditioning system.
- During air conditioning system operation, you may occasionally notice a slight change in engine speed at idle as the air conditioning compressor cycles on. This is a normal system operation characteristic.

این شبانه روزی: ۰۲۱-۸۸۸۶۲۰۸۵

FarmaSOS.com

- Use the air conditioning system every month if only for a few minutes to ensure maximum system performance.
- When using the air conditioning system, you may notice clear water dripping (or even puddling) on the ground under the passenger side of the vehicle. This is a normal system operation characteristics.
- The air conditioning system includes a function that automatically turns the air conditioning compressor off if engine coolant temperature approaches an overheating level. The air conditioning compressor operation will resume once engine coolant temperature returns to the normal range. Also, the air conditioning compressor is automatically turned off for a few seconds when the accelerator is fully depressed (wide open throttle).

- When operating the air conditioning system use the outside (fresh) air position.
- Operating the air conditioning system in the recirculated air position does provide maximum cooling, however, continual operation in this mode may cause the air inside the vehicle to become stale.

Checking the amount of air conditioner refrigerant and compressor lubricant

When the amount of refrigerant is low, the performance of the air conditioning is reduced. Overfilling also has a bad influence on the air conditioning system.

Therefore, if abnormal operation is found, have the system inspected by an authorized Kia dealer.

1

2

3

4

5

6

7

8

9

تلفن شبانه روزی: ۰۸۵-۸۸۸۶۲-۱

PharmaSOS.com

Air conditioner refrigerant and compressor lubricant

1

CAUTION

The air conditioning system should be serviced by an authorized Kia dealer. Improper service may cause serious injury.

2

3

4

*** NOTICE**

When the performance of the air conditioning system is reduced it is important that the correct type and amount of oil and refrigerant is used. Otherwise, damage to the compressor and abnormal system operation may occur.

5

6

7

8

9

امداد خودرو فارما

تلفن شبانه روزی: ۰۸۵-۸۸۸۶۲-۲۱

FarmaSOS.com

WINDSHIELD DEFROSTING AND DEFOGGING

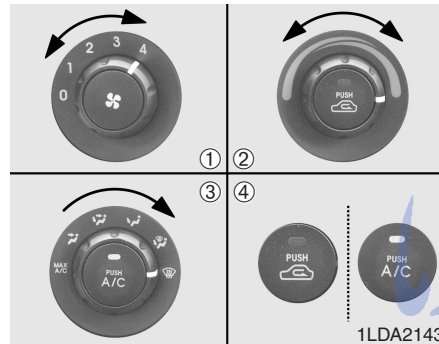

Manual climate control system

To defog inside windshield

1. Select any fan speed except "0".
2. Select desired temperature.
3. Select the or position.
4. The outside (fresh) air and air conditioning will be selected.

If the air-conditioning and outside (fresh) air position are not selected automatically, press the corresponding button manually.

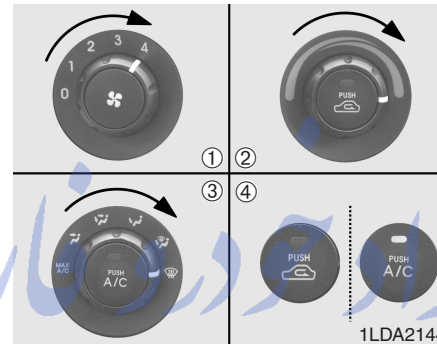

To defrost outside windshield

1. Set the fan speed to the "3" or "4" position.
2. Set the temperature to the extreme hot position.
3. Select the position.
4. The outside (fresh) air and air conditioning will be selected.

If the air-conditioning and outside (fresh) air position are not selected automatically, press the corresponding button manually.

CAUTION

Do not use the or position during cooling operation in extremely humid weather. The difference between the temperature of the outside air and that of the windshield could cause the outer surface of the windshield to fog up, causing loss of visibility. In this case, set the mode selection knob to the position and fan speed control knob to the lower speed.

1

2

3

4

5

6

7

8

9

- 1
- 2
- 3
- 4
- 5
- 6
- 7
- 8
- 9

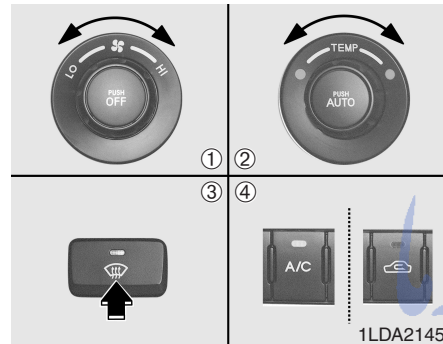

Automatic climate control system

To defog inside windshield

1. Select desired fan speed.
 2. Select desired temperature.
 3. Press the defrost button ().
 4. The air-conditioning will be turned on according to the detected ambient temperature and outside (fresh) air position will be selected.
- If the air-conditioning and outside (fresh) air position are not selected automatically, press the corresponding button manually.

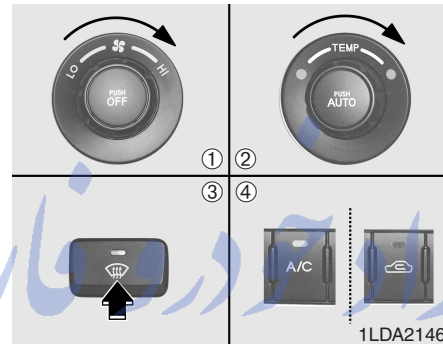

To defrost outside windshield

1. Set fan speed to the HI (extreme right) position.
 2. Set temperature to the extreme hot (25~32°C / 77~90°F) position.
 3. Press the defrost button ().
 4. The air-conditioning will be turned on according to the detected ambient temperature and outside (fresh) air position will be selected.
- If the air-conditioning and outside (fresh) air position are not selected automatically, press the corresponding button manually.

CAUTION







Do not use the or position during cooling operation in extremely humid weather. The difference between the temperature of the outside air and that of the windshield could cause the outer surface of the windshield to fog up, causing loss of visibility. In this case, set the mode selection knob to the position and fan speed control knob to the lower speed.



- For maximum defrosting, set the temperature control to the extreme right/hot position and the fan speed control to the highest speed.
- If warm air to the floor is desired while defrosting or defogging, set the mode to the floor-defrost position.
- Before driving, clear all snow and ice from the windshield, rear window, outside rear view mirrors, and all side windows.
- Clear all snow and ice from the hood and air inlet in the cowl grill to improve heater and defroster efficiency and to reduce the probability of fogging up inside of the windshield.

Defogging logic

Manual climate control system

To reduce the probability of fogging up the inside of the windshield, the air intake control is set to the outside (fresh) air position automatically if any of following occur.

- The mode is selected to the ,  or  while the system is activated.
- The ignition switch is turned on while the mode is selected to the ,  or .



In this case, the air conditioning will automatically operate if the mode is selected to the  or . *بفوق شیشه روزی.*

If you don't want the air-conditioning or outside (fresh) air position, press the corresponding button to cancel the operation.

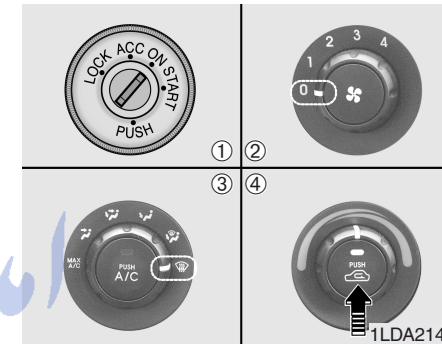
FarmaSOS.com



How to cancel or return defogging logic of manual climate control system

1. Turn the ignition switch to the “ON” position.
2. Turn the fan speed control knob to the “0” position.
3. Turn the mode selection knob to the defrost position ().
4. Push the air intake control button () at least 5 times within 3 seconds.





- 1
- 2
- 3
- 4
- 5
- 6
- 7
- 8
- 9



Then the indicator light in the air intake control button will blink 3 times with 0.5 second of interval. It indicates that the defogging logic is canceled or returned to the programmed status.

If the battery has been discharged or disconnected, it is reset as the defog logic status.

Automatic climate control system

To reduce the probability of fogging up inside of the windshield, the air intake control is set to outside (fresh) air position automatically if any of following occur.



- The ignition switch is turned on.
- The OFF button is pushed.
- The mode is selected to the  or  position.

In this case, the air conditioning will automatically operate if the mode is selected to the  or .

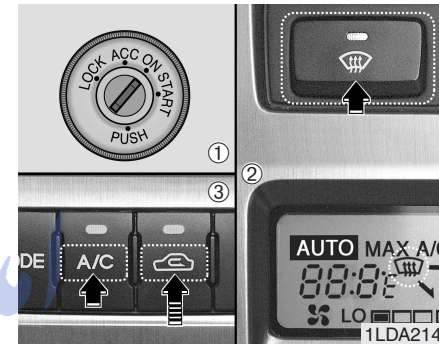
If you don't want the air-conditioning or outside (fresh) air position, press the corresponding button to cancel the operation.



How to cancel or return defogging logic of automatic climate control system

1. Turn the ignition switch to the "ON" position.
2. Select the defrost position pressing defrost button (.
3. While holding the air conditioning button (A/C) pressed, press the air intake control button () at least 5 times within 3 seconds.

The A/C display blinks 3 times with 0.5 second of interval. It indicates that the defogging logic is canceled or returned to the programmed status.

If the battery has been discharged or disconnected, it is reset as the defog logic status.

امداد خودرو فارما

تلفن شبانه روزی: ۰۲۱-۸۸۸۶۲۰۸۵

FarmaSOS.com

1

2

3

4

5

6

7

8

9

THEFT-ALARM SYSTEM (IF EQUIPPED)

- 1
- 2
- 3
- 4**
- 5
- 6
- 7
- 8
- 9

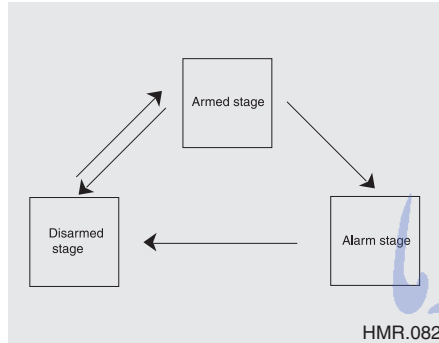

Armed stage

The Theft-Alarm system is armed as follows

- After all doors, engine hood, and trunk are locked, press the “LOCK” button on the transmitter once. The hazard flasher lights will flash once when the button is pressed, then twice when the button is released. (At this time, the alarm does not sound.)

Alarm stage

The alarm will be activated when:

- Any door is opened without using the key or the transmitter.
- The trunk lid is opened without using the key.
- The engine hood is opened.

The alarm sound and flash will be ON for 30 seconds. During this time, the engine will not start (For Europe).

The alarm will sound ON for 30 seconds, then OFF for 10 seconds. This ON/OFF cycle will be repeated three times. During this time, the engine will not start (Except Europe).

Withheld alarm

When the alarm is armed, the alarm will not sound if the trunk lid is opened with either the key or the transmitter.



However, if the trunk lid is not opened completely within two seconds after unlocking with the key or transmitter, or if any of the doors or hood is opened while the trunk lid is open and the alarm armed, the alarm will sound.

Disarmed stage

The armed stage will be deactivated when:

- The “” button on the transmitter is pressed.
After depressing unlock button, you must open the doors within 30 seconds or all doors will be locked again and automatically placed into the armed stage.
- The ignition switch is in the “ON” position.
- The doors are unlocked with the ignition key.

The alarm will be deactivated when:

- The lock () , unlock () or trunk lid open () button on the transmitter is pressed.
- The ignition switch is in the “ON” position for 30 seconds or more.
- The doors are unlocked with the ignition key.

*** NOTICE**

If the ignition key is in the ignition switch, the transmitter will not function. Avoid trying to start the engine with the alarm activated.

تلفن شبانه روزی: ۰۲۱-۸۸۸۸۸۸۸۸

FarmaSOS.com

1

2

3

4

5

6

7

8

9

ایران خودرو فارما

Fuel requirements / 5-2

1

Emission control system / 5-3

Before driving / 5-5

2

Suggestions for economical operation / 5-6

Special driving conditions / 5-7

Trailer towing / 5-13

3

Overloading / 5-21

Loading your vehicle / 5-22

Label information / 5-23

4

Driving tips

5

تلفن شبانه روزی: ۰۲۱-۸۸۸۶۳۰۸۵

6

7

FarmaSOS.com

8

9

FUEL REQUIREMENTS

Gasoline engine (unleaded)

Your new Kia vehicle is designed to use only unleaded fuel having an Octane Rating of RON (Research Octane Number) 91 / AKI (Anti-Knock Index) 87 or higher.

Your new Kia is designed to obtain maximum performance with UNLEADED FUEL, as well as minimize exhaust emissions and spark plug fouling.

* NOTICE

NEVER USE LEADED FUEL. The use of leaded fuel is detrimental to the catalytic converter and will damage the engine control system's oxygen sensor and affect emission control.

Never add any fuel system cleaning agents to the fuel tank other than what Kia has specified. (Consult an Authorized Kia Dealer for details.)

Gasoline Engine (Leaded)

In countries using LEADED FUEL, your new Kia vehicle must use LEADED FUEL. Your new Kia Vehicle is designed to correspond to LEADED FUEL specifically. Please check your vehicle whether your vehicle can use LEADED FUEL or not.

Gasoline containing alcohol and methanol

Gasohol, a mixture of gasoline and ethanol (also known as grain alcohol), and gasoline or gasohol containing methanol (also known as wood alcohol) are being marketed along with or instead of leaded or unleaded gasoline.

Do not use gasohol containing more than 10% ethanol, and do not use gasoline or gasohol containing any methanol. Either of these fuels may cause drivability problems and damage to the fuel system.

Discontinue using gasohol of any kind if drivability problems occur.

1

2

3

4

5

6

7

8

9

EMISSION CONTROL SYSTEM

Vehicle damage or driveability problems may not be covered by the manufacturer's warranty if they result from the use of:

1. Gasohol containing more than 10% ethanol.
2. Gasoline or gasohol containing methanol.
3. Leaded fuel or leaded gasohol.

* NOTICE

Never use gasohol which contains methanol. Discontinue use of any gasohol product which impairs drivability.

The emission control system of your vehicle is covered by a written limited warranty. Please see the warranty information contained in the Warranty & Maintenance book in your vehicle.

Vehicle modifications

This vehicle should not be modified. Modification of your Kia could affect its performance, safety or durability and may even violate governmental safety and emissions regulations.

In addition, damage or performance problems resulting from any modification may not be covered under warranty.

Engine exhaust gas precautions (carbon monoxide)

⚠ WARNING

Engine exhaust gases contain carbon monoxide (CO). Though colourless and odorless, it is dangerous and could be lethal if inhaled. Follow the instructions following to avoid CO poisoning.

- Carbon monoxide can be present with other exhaust fumes. Therefore, if you smell exhaust fumes of any kind inside your vehicle, have it inspected and repaired immediately by an authorized Kia dealer. If you ever suspect exhaust fumes are coming into your vehicle, drive it only with all the windows fully open. Have your vehicle checked and repaired immediately.

1

2

3

4

5

6

7

8

9

1

- Do not operate the engine in confined or closed areas (such as garages) any more than what is necessary to move the vehicle in or out of the area.

2

- When the vehicle is stopped in an open area for more than a short time with the engine running, adjust the ventilation system (as needed) to draw outside air into the vehicle.

3

- Never sit in a parked or stopped vehicle for any extended time with the engine running.

5

- Inspect the emission control system whenever engine stalls.

6

- If the engine stalls or fails to start, do not re-engaging the starter over 3 times. If the engine stalls or re-engaged excessively, it may cause damage to the emission control system.

7

8

9

Operating precautions for catalytic converters

⚠ WARNING - Fire

A hot exhaust system can ignite flammable items under your vehicle. Do not park the vehicle over or near flammable objects, such as dry grass, paper, leaves, etc.

Your vehicle is equipped with a catalytic converter emission control device.

Therefore, the following precautions must be observed:

- Use only UNLEADED FUEL for gasoline engine (unleaded).
- Do not operate the vehicle when there are signs of engine malfunction, such as misfire or a noticeable loss of performance.
- Do not misuse or abuse the engine. Examples of misuse are coasting with the ignition off and descending steep grades in gear with the ignition off.

- Do not operate the engine at high idle speed for extended periods (5 minutes or more).
- Do not modify or tamper with any part of the engine or emission control system. All inspections and adjustments must be made by an authorized Kia dealer.

Failure to observe these precautions could result in damage to the catalytic converter and to your vehicle. Additionally, such actions could void your warranties.

BEFORE DRIVING

Before entering vehicle:

- Be sure that all windows, outside mirror(s), and outside lights are clean.
- Check the condition of the tyres.
- Check under the vehicle for any sign of leaks.
- Be sure there are no obstacles behind you if you intend to back up.

Necessary inspections

Fluid levels, such as engine oil, engine coolant, brake fluid, and washer fluid should be checked on a regular basis, with the exact interval depending on the fluid. Further details are provided in Section 7, Maintenance.

Before starting

- Close and lock all doors.
 - Position the seat so that all controls are easily reached.
 - Adjust the inside and outside rearview mirrors.
 - Be sure that all lights work.
 - Check all gauges.
 - Check the operation of warning lights when the ignition switch is turned to the ON position.
 - Release the parking brake and make sure the brake warning light goes out.
- For safe operation, be sure you are familiar with your vehicle and its equipment.

⚠ WARNING - Driving under the influence of alcohol or drugs

Drinking and driving is dangerous. Drunk driving is the number one contributor to the highway death toll each year. Even a small amount of alcohol will affect your reflexes, perceptions and judgement.

You are much more likely to have a serious accident if you drink and drive.

If you are drinking or taking drugs, don't drive. Do not ride with a driver who has been drinking or taking drugs. Choose a designated driver or call a cab.

Driving while under the influence of drugs is as dangerous or more dangerous than driving drunk.

1

2

3

4

5

6

7

8

9

SUGGESTIONS FOR ECONOMICAL OPERATION

Your vehicle's fuel economy depends mainly on your style of driving, where you drive and when you drive.

1

Each of these factors affects how many kilometers (miles) you can get from a litre (gallon) of fuel. To operate your vehicle as economically as possible, use the following driving suggestions to help save money in both fuel and repairs:

2

3

4

5

- Avoid lengthy warm-up idling. Once the engine is running smoothly, begin driving. Remember, engine warm-up may take a little longer on cold days.

6

- Save fuel by accelerating slowly after stopping.

7

- Keep the engine in tune and follow the recommended periodic maintenance schedule. This will increase the life of all parts and lower your operating costs.

8

9

- Do not use the air conditioner unnecessarily.
- Slow down when driving on rough roads.
- For longer tyre life and better fuel economy, always keep the tyres inflated to the recommended pressures.
- Maintain a safe distance from other vehicles to avoid sudden stops. This will reduce wear on brake linings and pads. Driving in such a way will also save fuel because extra fuel is required to accelerate back to driving speed.
- Do not carry unnecessary weight in the vehicle.
- Do not rest your foot on the brake pedal while driving. This can cause needless wear, possible damage to the brakes, and poor fuel economy.
- Improper wheel alignment results in faster tyre wear and lower fuel economy.
- Open windows at high speeds can reduce fuel economy.
- Fuel economy is less in crosswinds and headwinds. To help offset some of this loss, slow down when driving in these conditions.

Keeping a vehicle in good operating condition is important both for economy and safety. Therefore, have an authorized Kia dealer perform scheduled inspections and maintenance.

⚠ WARNING - Engine off during motion

Never turn the engine off to coast down hills or anytime the vehicle is in motion. The power steering and power brakes will not function without the engine running. Instead, keep the engine on and downshift to an appropriate gear for engine braking effect.

SPECIAL DRIVING CONDITIONS

Hazardous driving conditions

When hazardous driving conditions are encountered such as water, snow, ice, mud, sand, or similar hazards, follow these suggestions:

- Drive cautiously and allow extra distance for braking.
- Avoid sudden movements in braking or steering.
- When braking, pump the brake pedal with a light up-and-down motion until the vehicle is stopped.

* NOTICE

Do not pump the brake pedal on a vehicle equipped with ABS.

- If stalled in snow, mud, or sand, use second gear. Accelerate slowly to avoid spinning the drive wheels.
- Use sand, rock salt, tyre chains, or other non-slip material under the drive wheels to provide traction when stalled in ice, snow, or mud.

⚠ WARNING - Downshifting
Downshifting with an automatic transaxle, while driving on slippery surfaces can cause an accident. The sudden change in tyre speed could cause the tyres to skid. Be careful when downshifting on slippery surfaces.

Rocking the vehicle

If it is necessary to rock the vehicle to free it from snow, sand, or mud, first turn the steering wheel right and left to clear the area around your front wheels. Then, shift back and forth between 1 (First) and R (Reverse) in vehicles equipped with a manual transaxle or R (Reverse) and any forward gear in vehicles equipped with an automatic transaxle. Do not race the engine, and spin the wheels as little as possible. If you are still stuck after a few tries, have the vehicle pulled out by a tow vehicle to avoid engine overheating and possible damage to the transaxle.

* NOTICE

Prolonged rocking may cause engine over-heating, transaxle damage or failure, and tyre damage.



1

2

3

4

5

6

7

8

9

⚠ WARNING - Spinning tyres
Do not spin the wheels, especially at speeds more than 56 km/h (35 mph). Spinning the wheels at high speeds when the vehicle is stationary could cause a tyre to overheat, explode and injure bystanders.

Driving at night

Because night driving presents more hazards than driving in the daylight, here are some important tips to remember:

- Slow down and keep more distance between you and other vehicles, as it may be more difficult to see at night, especially in areas where there may not be any street lights.
- Adjust your mirrors to reduce the glare from other driver's headlights.
- Keep your headlights clean and properly aimed on vehicles not equipped with the automatic headlight aiming feature. Dirty or improperly aimed headlights will make it much more difficult to see at night.
- Avoid staring directly at the headlights of oncoming vehicles. You could be temporarily blinded, and it will take several seconds for your eyes to readjust to the darkness.

Driving in the rain

Rain and wet roads can make driving dangerous, especially if you're not prepared for the slick pavement. Here are a few things to consider when driving in the rain:

- A heavy rainfall will make it harder to see and will increase the distance needed to stop your vehicle, so slow down.
- Keep your windshield wiping equipment in good shape. Replace your windshield wiper blades when they show signs of streaking or missing areas on the windshield.
- If your tyres are not in good condition, making a quick stop on wet pavement can cause a skid and possibly lead to an accident. Be sure your tyres are in good shape.
- Turn on your headlights to make it easier for others to see you.

- Driving too fast through large puddles can affect your brakes. If you must go through puddles, try to drive through them slowly.
- If you believe you may have gotten your brakes wet, apply them lightly while driving until normal braking operation returns.

Winter driving

- We recommend that you carry emergency equipment, including tyre chains, a window scraper, windshield de-icer, a bag of sand or salt, flares, a small shovel and jumper cables.
- Make sure you have sufficient ethylene-glycol coolant in the radiator.
- Check the battery condition and cables. Cold temperatures reduce the capacity of any battery, so it must be in excellent condition to provide enough winter starting power.
- Make sure the engine oil viscosity is suitable for cold weather.
- Check the ignition system for loose connections and damage.

- Use antifreeze-formulated windshield washer fluid. (Do not use engine coolant antifreeze.)
- Do not use the parking brake if it might freeze. When parking, shift to 1 (First) or R (Reverse) with a manual transaxle or P (Park) with an automatic transaxle and block the rear wheels.

1

2

3

4

5

6

7

8

9

FarmaSOS.com

1

Snow tyres

If you mount snow tyres on your Kia, make sure they are radial tyres of the same size and load range as the original tyres. Mount snow tyres on all four wheels to balance your vehicle's handling in all weather conditions. Keep in mind that the traction provided by snow tyres on dry roads may not be as high as your vehicle's original equipment tyres. You should drive cautiously even when the roads are clear. Check with the tyre dealer for maximum speed recommendations.

2

3

4

5

6

7

8

9

⚠ WARNING - Snow tyre size

Snow tyres should be equivalent in size and type to the vehicle's standard tyres. Otherwise, the safety and handling of your vehicle may be adversely affected.

Do not install studded tyres without first checking local, state and municipal regulations for possible restrictions against their use.



1LDN3010

Tyre chains

Since the sidewalls of radial tyres are thinner, they can be damaged by mounting some types of snow chains on them. Therefore, the use of snow tyres is recommended instead of snow chains. Do not mount tyre chains on vehicles equipped with aluminum wheels, snow chains may cause damage to the wheels. If snow chains must be used, use wire-type chains with a thickness of less than 15 mm (0.59 in). Damage to your vehicle caused by improper snow chain use is not covered by your vehicle manufacturers warranty.

Install them only on the front tyres.

شبانہ روزی: ۰۲۱-۸۸۶۲۰۸۵

FarmaSOS.com

*** NOTICE**

- Make sure the snow chains are the correct size and type for your tyres. Incorrect snow chains can cause damage to the vehicle body and suspension and may not be covered by your vehicle manufacturer warranty. Also, the snow chain connecting hooks may be damaged from contacting vehicle components causing the snow chains to come loose from the tyre. Make sure the snow chains are SAE class “S” certified.
- Always check chain installation for proper mounting after driving approximately 0.5 to 1 km (0.3 to 0.6 miles) to ensure safe mounting. Retighten or remount the chains if they are loose.

Chain installation

When installing chains, follow the manufacturer's instructions and mount them as tightly as you can. Drive slowly with chains installed. If you hear the chains contacting the body or chassis, stop and tighten them. If they still make contact, slow down until it stops. Remove the chains as soon as you begin driving on cleared roads.

⚠ WARNING
- Mounting chains

When mounting snow chains, park the vehicle on level ground away from traffic. Turn on the vehicle Hazard Warning flashers and place a triangular emergency warning device behind the vehicle if available. Always place the vehicle in park (P), apply the parking brake and turn off the engine before installing snow chains.

⚠ WARNING - Tyre chains

- The use of chains may adversely affect vehicle handling.
- Do not exceed 30 km/h (20 mph) or the chain manufacturer's recommended speed limit, whichever is lower.
- Drive carefully and avoid bumps, holes, sharp turns, and other road hazards, which may cause the vehicle to bounce.
- Avoid sharp turns or locked-wheel braking.
- Chains that are the wrong size or improperly installed can damage your vehicle's brake lines, suspension, body and wheels.
- Stop driving and retighten the chains any time you hear them hitting the vehicle.

1

2

3

4

5

6

7

8

9

Driving in flooded areas

1

Avoid driving through flooded areas unless you are sure the water is no higher than the bottom of the wheel hub. Drive through any water slowly.

2

Allow adequate stopping distance because brake performance may be affected.

3

After driving through water, dry the brakes by gently applying them several times while the vehicle is moving slowly.

4

5

6

7

8

9

امداد خودرو فارما
تلفن شبانه روزی: ۰۲۱-۸۸۸۶۲۰۸۵

FarmaSOS.com

TRAILER TOWING - FOR EUROPE AND AUSTRALIA

⚠ WARNING - Towing a trailer

If you don't use the correct equipment and drive properly, you can lose control when you pull a trailer. For example, if the trailer is too heavy, the brakes may not work well - or even at all. You and your passengers could be seriously or fatally injured. Pull a trailer only if you have followed all the steps in this section.

*** NOTICE**

Pulling a trailer improperly can damage your vehicle and result in costly repairs not covered by your warranty. To pull a trailer correctly, follow the advice in this section.

Item		Engine		Gasoline Engine		Diesel Engine
		Without brake System	1.6 Engine	2.0 Engine		
				For Australia	Except Australia	
Maximum trailer weight kg (lbs.)	Without brake System	550 (1212)	500 (1102)	550 (1212)	550 (1212)	
	With brake System	1200 (2645)	1000 (2205)	1400 (3086)	1400 (3086)	
Maximum permissible static vertical load on the coupling device kg (lbs.)		48 (105)	90 (198)	56 (123)	56 (123)	
Recommended distance from rear wheel centre to coupling point mm (Inch)		4 Door : 1065 (42) 5 Door : 925 (36)				

1

2

3

4

5

6

7

8

9

Driving tips

1

2

3

4

5

6

7

8

9

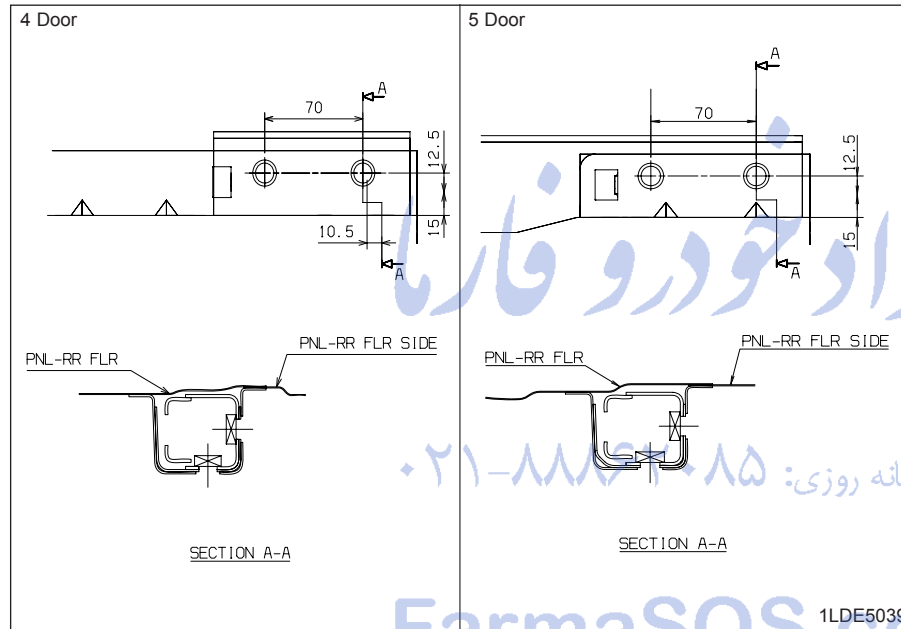

Your vehicle can tow a trailer. To identify what the vehicle trawling capacity is for your vehicle, you should read the information in "Weight of the Trailer" that appears later in this section.

Remember that trawling is different than just driving your vehicle by itself. Trawling means changes in handling, durability, and fuel economy. Successful, safe trawling requires correct equipment, and it has to be used properly.

This section contains many time-tested, important trawling tips and safety rules. Many of these are important for your safety and that of your passengers. Please read this section carefully before you pull a trailer.

Load-pulling components such as the engine, transaxle, wheel assemblies, and tyres are forced to work harder against the load of the added weight. The engine is required to operate at relatively higher speeds and under greater loads. This additional burden generates extra heat. The trailer also adds considerably to wind resistance, increasing the pulling requirements.

If you do decide to pull a trailer

Here are some important points if you decide to pull a trailer:

- Consider using a sway control. You can ask a hitch dealer about sway control.
- After your odometer indicates 800 km (500 miles) or more, you can tow a trailer. For the first 800 km (500 miles) that you tow a trailer, don't drive over 80 km/h (50 mph) and don't make starts at full throttle. This helps your engine and other parts of your vehicle "wear" in at the heavier loads.
- Always drive your vehicle at a moderate speed (less than 100 km/h).
- The important considerations have to do with weight:

Weight of the trailer

How heavy can a trailer safely be? It should never weigh more than the maximum trailer weight with trailer brakes. But even that can be too heavy.

It depends on how you plan to use your trailer. For example, speed, altitude, road grades, outside temperature and how much your vehicle is used to pull a trailer are all important. The ideal trailer weight can also depend on any special equipment that you have on your vehicle.



1

2

3

4

5

6

7

8

9

Weight of the trailer tongue

The tongue load of any trailer is an important weight to measure because it affects the total gross vehicle weight (GVW) of your vehicle. This weight includes the curb weight of the vehicle, any cargo you may carry in it, and the people who will be riding in the vehicle. And if you will tow a trailer, you must add the tongue load to the GVW because your vehicle will also be carrying that weight.

The trailer tongue should weigh a maximum of 4% of the total loaded trailer weight. After you've loaded your trailer, weigh the trailer and then the tongue, separately, to see if the weights are proper. If they aren't, you may be able to correct them simply by moving some items around in the trailer.

⚠ WARNING

- **Never load a trailer with more weight in the rear than in the front. The front should be loaded with approximately 60% of the total trailer load; the rear should be loaded with approximately 40% of the total trailer load.**
- **Never exceed the maximum weight limits of the trailer or trailer towing equipment. Improper loading can result in damage to your vehicle and/or personal injury. Check weights and loading at a commercial scale or highway patrol office equipped with scales.**
- **An improperly loaded trailer can cause loss of vehicle control.**

Hitches

It's important to have the correct hitch equipment. Crosswinds, large trucks going by, and rough roads are a few reasons why you'll need the right hitch. Here are some rules to follow:

- Will you have to make any holes in the body of your vehicle when you install a trailer hitch? If you do, then be sure to seal the holes later when you remove the hitch.
If you don't seal them, deadly carbon monoxide (CO) from your exhaust can get into your vehicle, as well as dirt and water.
- The bumpers on your vehicle are not intended for hitches. Do not attach rental hitches or other bumper-type hitches to them. Use only a frame-mounted hitch that does not attach to the bumper.

Safety chains

You should always attach chains between your vehicle and your trailer. Cross the safety chains under the tongue of the trailer so that the tongue will not drop to the road if it becomes separated from the hitch.

Instructions about safety chains may be provided by the hitch manufacturer or by the trailer manufacturer. Follow the manufacturer's recommendation for attaching safety chains. Always leave just enough slack so you can turn with your trailer. And, never allow safety chains to drag on the ground.

Trailer brakes

If your trailer weighs more than the maximum trailer weight without trailer brakes loaded, then it needs its own brakes and they must be adequate. Be sure to read and follow the instructions for the trailer brakes so you'll be able to install, adjust and maintain them properly.

- Don't tap into your vehicle's brake system.

⚠ WARNING

Do not use a trailer with its own brakes unless you are absolutely certain that you have properly set up the brake system. This is not a task for amateurs. Use an experienced, competent trailer shop for this work.

Driving with a trailer

Towing a trailer requires a certain amount of experience. Before setting out for the open road, you must get to know your trailer. Acquaint yourself with the feel of handling and braking with the added weight of the trailer. And always keep in mind that the vehicle you are driving is now a good deal longer and not nearly so responsive as your vehicle is by itself.

Before you start, check the trailer hitch and platform, safety chains, electrical connector(s), lights, tyres and mirror adjustment. If the trailer has electric brakes, start your vehicle and trailer moving and then apply the trailer brake controller by hand to be sure the brakes are working. This lets you check your electrical connection at the same time.

During your trip, check occasionally to be sure that the load is secure, and that the lights and any trailer brakes are still working.

1

2

3

4

5

6

7

8

9

1

Following distance

Stay at least twice as far behind the vehicle ahead as you would when driving your vehicle without a trailer. This can help you avoid situations that require heavy braking and sudden turns.

2

3

Passing

You'll need more passing distance up ahead when you're towing a trailer. And, because you're a good deal longer, you'll need to go much farther beyond the passed vehicle before you can return to your lane.

4

5

6

7

8

9

Backing up

Hold the bottom of the steering wheel with one hand. Then, to move the trailer to the left, just move your hand to the left. To move the trailer to the right, move your hand to the right. Always back up slowly and, if possible, have someone guide you.

Making turns

When you're turning with a trailer, make wider turns than normal. Do this so your trailer won't strike soft shoulders, curbs, road signs, trees, or other objects. Avoid jerky or sudden maneuvers. Signal well in advance.

Turn signals when towing a trailer

When you tow a trailer, your vehicle has to have a different turn signal flasher and extra wiring. The green arrows on your instrument panel will flash whenever you signal a turn or lane change. Properly connected, the trailer lights will also flash to alert other drivers you're about to turn, change lanes, or stop.

When towing a trailer, the green arrows on your instrument panel will flash for turns even if the bulbs on the trailer are burned out. Thus, you may think drivers behind you are seeing your signals when, in fact, they are not. It's important to check occasionally to be sure the trailer bulbs are still working. You must also check the lights every time you disconnect and then reconnect the wires.

Do not connect a trailer lighting system directly to your vehicle's lighting system. Use only an approved trailer wiring harness.

Your Authorized Kia Dealer can assist you in installing the wiring harness.

CAUTION

Failure to use an approved trailer wiring harness could result in damage to the vehicle electrical system and/or personal injury.

Driving on grades

Reduce speed and shift to a lower gear before you start down a long or steep downgrade. If you don't shift down, you might have to use your brakes so much that they would get hot and no longer operate efficiently.

On a long uphill grade, shift down and reduce your speed to around 70 km/h (45 mph) to reduce the possibility of engine and transaxle overheating.

If your trailer weighs more than the maximum trailer weight without trailer brakes and you have an automatic transaxle, you should drive in D (Drive) when towing a trailer.

Operating your vehicle in D (Drive) when towing a trailer will minimize heat buildup and extend the life of your transaxle.

If you have a manual transaxle, drive in fourth gear (or, as you need to, a lower gear).

*** NOTICE**

- When towing a trailer on steep grades (in excess of 12%) pay close attention to the engine coolant temperature gauge to ensure the engine does not overheat. If the needle of the coolant temperature gauge moves across the dial towards "H" (HOT), pull over and stop as soon as it is safe to do so, and allow the engine to idle until it cools down. You may proceed once the engine has cooled sufficiently.
- You must decide driving speed depending on trailer weight and uphill grade to reduce the possibility of engine and transaxle overheating.



FarmasOS.com

1

Parking on hills

Generally, you should not park your vehicle, with a trailer attached, on a hill. People can be seriously or fatally injured, and both your vehicle and the trailer can be damaged if they begin a downhill trajectory.

2

3

⚠ WARNING - Parking on a hill

Parking your vehicle on a hill with a trailer attached could cause serious injury or death, should the trailer break loose.

4

5

6

7

8

9

However, if you ever have to park your trailer on a hill, here's how to do it:

1. Apply your brakes, but don't shift into gear.
2. Have someone place chocks under the trailer wheels.
3. When the wheel chocks are in place, release the brakes until the chocks absorb the load.
4. Reapply the brakes. Apply your parking brake, and then shift to R (Reverse) for a manual transaxle or P (Park) for an automatic transaxle.
5. Release the brakes.

⚠ WARNING - Parking brake

It can be dangerous to get out of your vehicle if the parking brake is not firmly set.

If you have left the engine running, the vehicle can move suddenly. You or others could be seriously or fatally injured.

When you are ready to leave after parking on a hill

1. With the manual transaxle in Neutral or automatic transaxle in P (Park), apply your brakes and hold the brake pedal down while you:
 - Start your engine;
 - Shift into gear; and
 - Release the parking brake.
2. Slowly remove your foot from the brake pedal.
3. Drive slowly until the trailer is clear of the chocks.
4. Stop and have someone pick up and store the chocks.

Maintenance when trailer towing

Your vehicle will need service more often when you regularly pull a trailer. Important items to pay particular attention to include engine oil, automatic transaxle fluid, axle lubricant and cooling system fluid. Brake condition is another important item to frequently check. Each item is covered in this manual, and the Index will help you find them quickly. If you're trailering, it's a good idea to review these sections before you start your trip.

Don't forget to also maintain your trailer and hitch. Follow the maintenance schedule that accompanied your trailer and check it periodically. Preferably, conduct the check at the start of each day's driving. Most importantly, all hitch nuts and bolts should be tight.

* NOTICE

- Due to higher load during trailer usage, overheating might occur in hot days or during uphill driving. If the coolant gauge indicates over-heating, switch off the A/C and stop the vehicle in a safe area to cool down the engine.
- When towing check transaxle fluid more frequently.
- If your vehicle is not equipped with the air conditioner, you should install a condenser fan to improve engine performance when towing a trailer.

OVERLOADING

⚠ CAUTION

The gross axle weight rating (GAWR) and the gross vehicle weight rating (GVWR) for your vehicle are on the manufacturer's label attached to the driver's door. Exceeding these ratings can cause an accident or vehicle damage. You can calculate the weight of your load by weighing the items (or people) before putting them in the vehicle. Be careful not to overload your vehicle.

1

2

3

4

5

6

7

8

9

تلفن شبانه روزی: ۰۸۵-۸۸۸۶۲-۱
ParmaSOS.com

LOADING YOUR VEHICLE - FOR AUSTRALIA

1

2

3

4

5

6

7

8

9



The Certification/Tyre label is found on the front edge of the RH "B" pillar. The label shows the size of your original tyres and inflation pressures needed to obtain the gross weight capacity of your vehicle.

This is called the GVWR (Gross Vehicle Weight Rating). The GVWR includes the weight of the vehicle, all occupants, fuel and cargo. The Certification/Tyre label also tells you the maximum weights for the front and rear axles, called Gross Axle Weight Rating (GAWR).

Never exceed the GVWR for your vehicle, or the Gross Axle Weight Rating (GAWR) for either the front or rear axle. And, if you do have a heavy load, you should spread it out.

CAUTION

Do not load your vehicle any heavier than the GVWR or the maximum front and rear GAWRs. If you do, change to the vehicle may occur, or it can change the way your vehicle handles. These could cause you to lose control. Also, overloading can shorten the life of your vehicle.

*** NOTICE**

Your warranty does not cover parts or components that fail because of overloading.

FarmaSOS.com

LABEL INFORMATION

There are several important labels and identification numbers located on your vehicle. The label locations are identified in the illustrations shown.

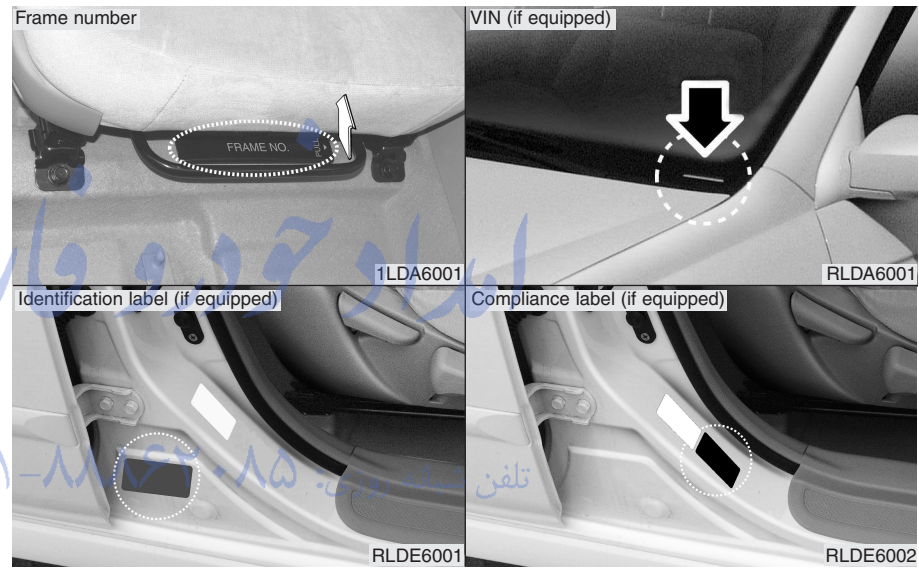

Vehicle identification number (VIN)

To check the frame number under the driver seat, remove the cover by pulling one side marked with "PULL".

- 1
- 2
- 3
- 4
- 5
- 6
- 7
- 8
- 9

1

2

3

4

5

6

7

8

9



Tyre specification / pressure label

تلفن شبانه روزی: ۰۲۱-۸۸۸۶۲۰۸۵

FarmaSOS.com

امداد خودرو فارما

۰۲۱-۸۸۸۶۲۰۴۸

In case of an emergency

FarmaSOS.com

Road warning / 6-2	1
Overheating / 6-3	
Emergency starting / 6-4	2
Electrical circuit protection / 6-7	
Towing / 6-14	
If you have a flat tyre / 6-19	3
	4
	5
In case of an emergency	6
	7
	8
	9

ROAD WARNING



Hazard warning flasher

The hazard warning flasher serves as a warning to other drivers to exercise extreme caution when approaching, overtaking, or passing your vehicle.

It should be used whenever emergency repairs are being made or when the vehicle is stopped near the edge of a roadway.

Depress the flasher switch with the ignition switch in any position. The flasher switch is located in the centre console switch panel. All turn signal lights will flash simultaneously.

- The hazard warning flasher operates whether your vehicle is running or not.
- The turn signals do not work when the hazard flasher is on.
- Care must be taken when using the hazard warning flasher while the vehicle is being towed.

OVERHEATING

If your temperature gauge indicates overheating, if you experience a loss of power, or if you hear a loud knocking or pinging noise, the engine has probably overheated. Should any of these symptoms occur, use the following procedure:

1. Turn on the hazard warning flasher, then drive to the nearest safe location and stop your vehicle; set the automatic transaxle in P (Park), or shift the manual transaxle to N (Neutral) and apply the parking brake.
2. Make sure the air conditioner is off.
3. If coolant or steam is boiling out of the radiator, stop the engine and call an Authorized Kia Dealer for assistance.

If coolant is not boiling out, allow the engine to idle and open the hood to permit the engine to cool gradually.

If the temperature does not go down with the engine idling, stop the engine and allow sufficient time for it to cool.

4. The coolant level should then be checked. If the level in the reservoir is low, look for leaks at the radiator hoses and connections, heater hoses and connections, radiator, and water pump. If you find a major leak or another problem that may have caused the engine to overheat, do not operate the engine until it has been corrected. Call an Authorized Kia Dealer for assistance. If you do not find a leak or other problem, carefully add coolant to the reservoir.

⚠ WARNING - Removing radiator cap

Do not remove the radiator cap when the engine and radiator are hot. Scalding hot coolant and steam may blow out under pressure. This could cause serious injury.

If the engine frequently overheats, have the cooling system checked and repaired by an Authorized Kia Dealer.

1

2

3

4

5

6

7

8

9

EMERGENCY STARTING

Jump starting

Jump starting can be dangerous if done incorrectly. Therefore, to avoid harm to yourself or damage to your vehicle or battery, follow the jump starting procedures listed on page 6-6. If in doubt, we strongly recommend that you have a competent technician or towing service jump start your vehicle.

1

2

3

4

5

6

7

8

9

* NOTICE

Use only a 12-volt jumper system. You can damage a 12-volt starting motor, ignition system, and other electrical parts beyond repair by use of a 24-volt power supply (either two 12-volt batteries in series or a 24-volt motor generator set).

⚠ WARNING - Battery

Never attempt to check the electrolyte level of the battery as this may cause the battery to rupture or explode causing serious injury.

⚠ WARNING - Battery

- Keep all flames or sparks away from the battery. The battery produces hydrogen gas which may explode if exposed to flame or sparks.
- Do not attempt to jump start the vehicle if the discharged battery is frozen or if the electrolyte level is low; the battery may rupture or explode.

Connecting jumper cables

Connect cables in numerical order and disconnect in reverse order.



- 1
- 2
- 3
- 4
- 5
- 6
- 7
- 8
- 9

1

Jump starting procedure

1. Make sure the booster battery is 12-volt and that its negative terminal is grounded.
2. If the booster battery is in another vehicle, do not allow the vehicles to touch.
3. Turn off all unnecessary electrical loads.
4. Connect the jumper cables in the exact sequence shown in the previous illustration. First connect one end of a jumper cable to the positive terminal of the discharged battery (①), then connect the other end to the positive terminal on the booster battery (②). Proceed to connect one end of the other jumper cable to the negative terminal of the booster battery (③), then the other end to a solid, stationary, metallic point (for example, the engine lifting bracket) away from the battery (④). Do not connect it to or near any part that moves when the engine is cranked. Do not connect the jumper cable from the negative terminal of the booster battery to the negative terminal of the discharged battery.

2

3

4

5

6

7

8

9

Do not allow the jumper cables to contact anything except the correct battery terminals or the correct ground. Do not lean over the battery when making connections.

5. Start the engine of the vehicle with the booster battery and let it run at 2,000 rpm, then start the engine of the vehicle with the discharged battery.

If the cause of your battery discharging is not apparent, you should have your vehicle checked by an Authorized Kia Dealer.

Refer to illustration on page 6-5.

Push-starting

Your manual transaxle-equipped vehicle should not be push-started because it might damage the emission control system.

Vehicles equipped with automatic transaxle cannot be push-started.

Follow the directions in this section for jump-starting.

CAUTION

Never tow a vehicle to start it because the sudden surge forward when the engine starts could cause a collision with the tow vehicle.

ELECTRICAL CIRCUIT PROTECTION

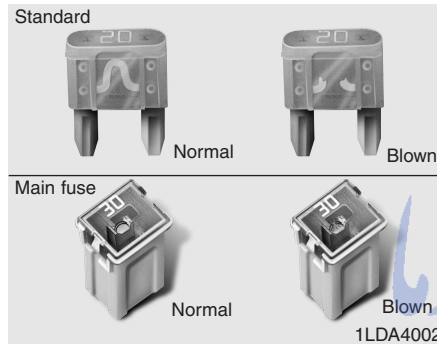

If any of your vehicle's lights, accessories, or controls do not work, check the appropriate circuit fuse. If a fuse has blown, the element inside the fuse will be melted.

If the electrical system does not work, first check the driver's side fuse panel.

Always replace a blown fuse with one of the same rating.

If the replacement fuse blows, this indicates an electrical problem. Avoid using the system involved and immediately consult an Authorized Kia Dealer.

Two kinds of fuses are used: standard for lower amperage rating and main for higher amperage ratings.

Fuses

A vehicle's electrical system is protected from electrical overload damage by fuses.

This vehicle has two fuse panels, one located in the driver's side knee bolster, the other in the engine compartment near the battery.

تلفن شبانه روزی: ۰۲۱-۸۸۸۶۲۰۸۵

FarmaSOS.com

- 1
- 2
- 3
- 4
- 5
- 6
- 7
- 8
- 9

Fuse replacement

1

⚠ WARNING - Fuse replacement

2

- Never replace a fuse with anything but another fuse of the same rating.

3

- A higher capacity fuse could cause damage through overheating and possibly a fire.

4

- Never install a wire instead of the proper fuse - even as a temporary repair. It may cause extensive wiring damage and possibly a fire.

5

- Do not use a screwdriver or any other metal object to remove fuses because it may cause a short circuit and damage the system.

6

7

8

9

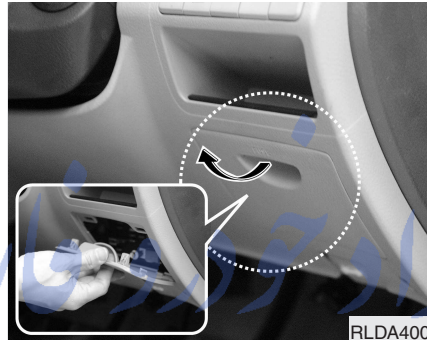

Driver-side knee bolster

1. Turn the ignition switch and all other switches off.
2. Pull the suspected fuse straight out. Use the removal tool provided on the cover.
3. Check the removed fuse; replace it if it is blown.

Spare fuses are provided in the fuse panel in engine compartment.

4. Push in a new fuse of the same rating, and make sure it fits tightly in the clips.

If it fits loosely, consult an Authorized Kia Dealer.

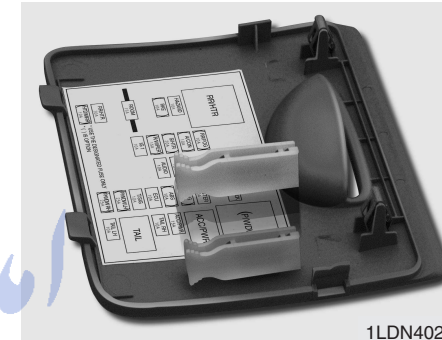

If you do not have a spare, use a fuse of the same rating from a circuit you may not need for operating the vehicle, such as the audio fuse.

If the headlights or other electrical components do not work and the fuses are OK, check the fuse block in the engine compartment. If a fuse is blown, it must be replaced.

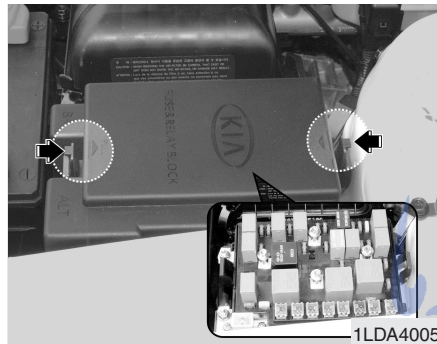

Engine compartment

1. Turn the ignition switch and all other switches off.
2. Remove the fuse box cover by pressing the taps on both ends and pulling up.
3. Check the removed fuse; replace it if it is blown.
4. Push in a new fuse of the same rating, and make sure it fits tightly in the clips.

If it fits loosely, consult an Authorized Kia Dealer.

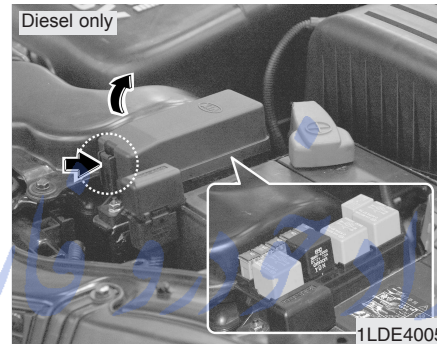

* NOTICE

After checking the fuse box in the engine compartment, securely install the fuse box cover. If not, electrical failures may occur from water leaking in.

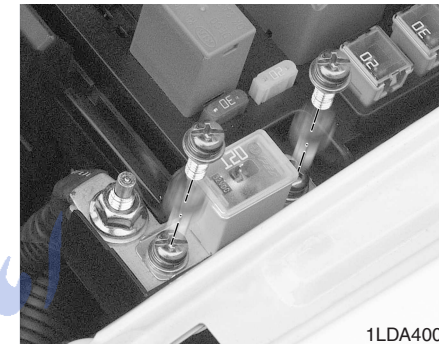

Main fuse

If the ALT (120A-Gasoline Engine, 140A-Diesel Engine) fuse is blown, it must be removed as follows:

1. Disconnect the negative battery cable.
2. Remove the screws shown in the picture above.
3. Replace the fuse with a new one of the same rating.
4. Reinstall in the reverse order of removal.

- 1
- 2
- 3
- 4
- 5
- 6
- 7
- 8
- 9

Engine compartment

Description	Fuse rating	Protected component
ATM	20A	Automatic transaxle control
ECU1	10A	Engine control unit
STOP	15A	Stop light
F/WIPER	20A	Front wiper
R/FOG	10A	Rear fog light
F/FOG	15A	Front fog light
LO HDLP	15A	Headlight (low)
HI HDLP	15A	Headlight (high)
A/CON	10A	Air conditioner
F/PUMP	15A	Fuel pump
T/OPEN	10A	Trunk lid opener
FOLD	10A	Outside rearview mirror folding
HORN	10A	Horn
DEICE	15A	Deicer
INJ	15A	Injection
SNSR	10A	O2 sensor
ECU2	30A	Engine control unit
SPARE	10A	spare fuse
SPARE	15A	spare fuse
SPARE	20A	spare fuse
SPARE	30A	spare fuse
ABS2	30A	Anti-lock brake system
ABS1	30A	Anti-lock brake system
IP B+	50A	In panel B+
BLOWER	30A	Blower
IGN2	30A	Ignition
IGN1	30A	Ignition

Description	Fuse rating	Protected component
RAD	30A	Radiator fan
COND	20A	Condenser fan
ALT	120A (Gasoline) 140A (Diesel)	Alternator
ATM	-	Automatic transaxle control relay
WIPER	-	Wiper relay
F/FOG	-	Front fog light relay
LO HDLP	-	Headlight relay (low)
HI HDLP	-	Headlight relay (high)
A/CON	-	Air conditioner relay
F/PUMP	-	Fuel pump relay
DRL	-	Daytime running light relay
COND2	-	Condenser fan relay
HORN	-	Horn relay
MAIN	-	Main relay
START	-	Start motor relay
RAD	-	Radiator fan relay
COND	-	Condenser fan relay

- 1
- 2
- 3
- 4
- 5
- 6
- 7
- 8
- 9

In case of an emergency

Driver-side knee bolster

- 1
- 2
- 3
- 4
- 5
- 6
- 7
- 8
- 9

Description	Fuse rating	Protected component
START	10A	Start motor
SRF/D_LOCK	20A	Sunroof, Door lock
RR FOG	10A	Rear fog light
HAZARD	10A	Hazard warning flasher
A/CON	10A	Air conditioner
CLUSTER	10A	Cluster
RKE	10A	Remote keyless entry
S/HTR	20A	Seat warmer
C/LIGHTER	15A	Cigar lighter
A/BAG	15A	Airbag
R/WIPER	15A	Rear wiper
AUDIO	10A	Audio
ABS	10A	Anti-lock brake system
ACC/PWR	15A	Accessory / Power socket
ROOM	15A	Room lamp
IGN	10A	Ignition
ECU	10A	Engine control unit
TAIL RH	10A	Tail light (right)
T/SIG	10A	Turn signal light
RR/HTR	30A	Rear window defroster
P/WDW LH	25A	Power window (left)
HTD/MIRR	10A	Outside rearview mirror heater
P/WDW RH	25A	Power window (right)
TAIL LH	10A	Tail light (left)

Description	Fuse rating	Protected component
RR/HTR	-	Rear window defroster relay
RESISTOR	-	Resistor
P/WDW	-	Power window relay
ACC/PWR	-	Accessory / Power socket relay
TAIL	-	Tail light relay

Engine compartment (Diesel only)

Description	Fuse rating	Protected component
F/HEATER	30A	Fuel filter heater
HEATER 3	40A	PTC heater 3
HEATER 2	40A	PTC heater 2
GLOW	60A	Glow plug
HEATER 1	40A	PTC heater 1
RELAY F/HEATER	-	Fuel filter heater relay
RELAY HEATER 3	-	PTC heater relay 3
RELAY HEATER 2	-	PTC heater relay 2
RELAY GLOW	-	Glow plug relay
RELAY HEATER 1	-	PTC heater relay 1

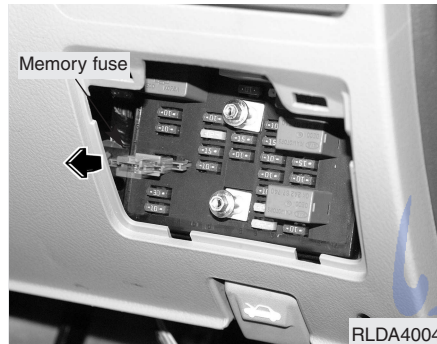

Memory fuse

Your vehicle is equipped with a memory fuse to prevent battery discharge if your vehicle is parked without being operated for prolonged periods. Use the following procedures before parking the vehicle for prolonged period.

1. Turn off the engine.
2. Turn off the headlights and tail lights.
3. Open the driver-side knee bolster cover and pull up the "ROOM 15A".

*** NOTICE**

- If the memory fuse is pulled up from the fuse panel, the warning chime, audio, clock and interior lamps, etc., will not operate. Some items must be reset after replacement. (Refer to "Items to be reset..." on page 7-44)
- Even though the memory fuse is pulled up, the battery can still be discharged by operation of the headlights or other electrical devices.

1
2
3
4
5
6
7
8
9

FarmaSOS.com

تلفن شبانه روزی: ۰۸۵-۸۸۶۲-۸۱

TOWING

1

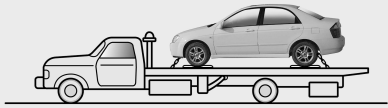

2



3

4

5

6

7

8

9

2LDA4001

If emergency towing is necessary, we recommend having it done by an authorized Kia dealer or a commercial tow-truck service. Proper lifting and towing procedures are necessary to prevent damage to the vehicle. The use of wheel dollies or flatbed is recommended.

For trailer towing guidelines information, refer to section 5 "Driving Tips".

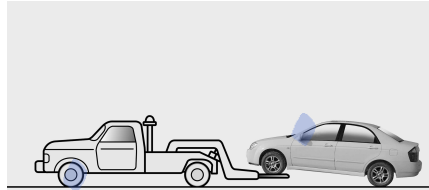

2LDA4002

It is acceptable to tow the vehicle with the rear wheels on the ground (without dollies) and the front wheels off the ground.

When being towed by a commercial tow truck and wheel dollies are not used, the front of the vehicle should always be lifted, not the rear.

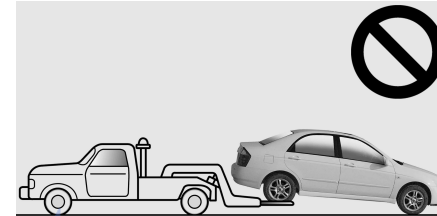

1LDN4023

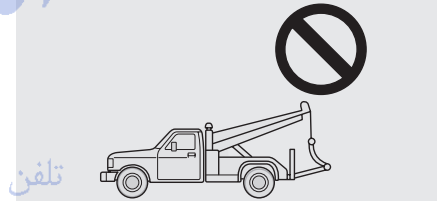

2GHA4107

* NOTICE

- Do not tow the vehicle backwards with the front wheels on the ground as this may cause damage to the vehicle.
- Do not tow with sling-type equipment. Use wheel lift or flatbed equipment.

When towing your vehicle in an emergency without wheel dollies :

1. Set the ignition switch in the ACC position.
2. Place the transaxle shift lever in N (Neutral).
3. Release the parking brake.

*** NOTICE**

Failure to place the transaxle shift lever in N (Neutral) may cause internal damage to the transaxle.



**Tie-down hook
(for flatbed towing)**

CAUTION

Do not use the hooks under the front of the vehicle for towing purposes. These hooks are designed ONLY for transport tie-down. If the tie-down hooks are used for towing, the tie-down hooks will be damaged and this could lead to serious injury.

1

2

3

4

5

6

7

8

9

- 1
- 2
- 3
- 4
- 5
- 6
- 7
- 8
- 9

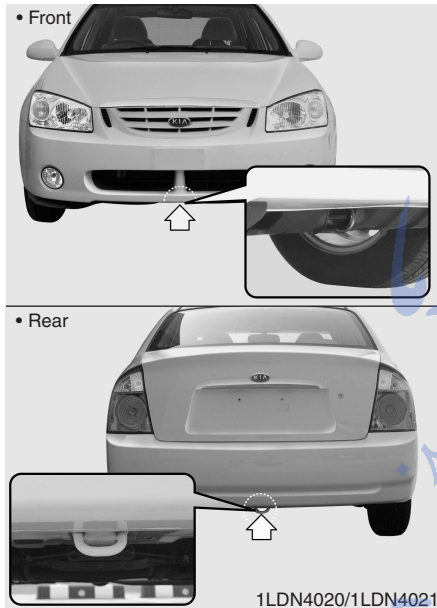

Towing with a vehicle other than a tow truck

If towing is necessary, we recommend you to have it done by an Authorized Kia dealer or a commercial tow truck service.

If towing service is not available in an emergency, your vehicle may be temporarily towed using a cable or chain secured to the emergency towing hook under the front or rear of the vehicle. Use extreme caution when towing the vehicle. A driver must be in the vehicle to steer it and operate the brakes.

Towing in this manner may be done only on hard-surfaced roads for a short distance and at low speeds. Also, the wheels, axles, power train, steering and brakes must all be in good condition.

- Do not use the tow hooks to pull a vehicle out of mud, sand or other conditions from which the vehicle cannot be driven out under its own power.
- Avoid towing a vehicle heavier than the vehicle doing the towing.
- The drivers of both vehicles should communicate with each other frequently.

تلفن شبانه روزی: ۰۸۵-۸۸۸۶۲-۲۱
FarmaSOS.com

*** NOTICE**

- Attach a towing strap to the tow hook.
- Using a portion of the vehicle other than the tow hooks for towing may damage the body of your vehicle.
- Use only a cable or chain specifically intended for use in towing vehicles. Securely fasten the cable or chain to the towing hook provided.
- Before emergency towing, check that the hook is not broken or damaged.
- Fasten the towing cable or chain securely to the hook.
- Do not jerk the hook. Apply steady and even force.
- To avoid damaging the hook, do not pull from the side or at a vertical angle. Always pull straight ahead.

CAUTION

Use extreme caution when towing the vehicle.

- *Avoid sudden starts or erratic driving maneuvers which would place excessive stress on the emergency towing hook and towing cable or chain. The hook and towing cable or chain may break and cause serious injury or damage.*
- *If the towing vehicle can hardly move, do not forcibly continue the towing. Contact an Authorized Kia dealer or a commercial tow truck service for assistance.*
- *Tow the vehicle as straight ahead as possible.*
- *Keep away from the vehicle during towing.*

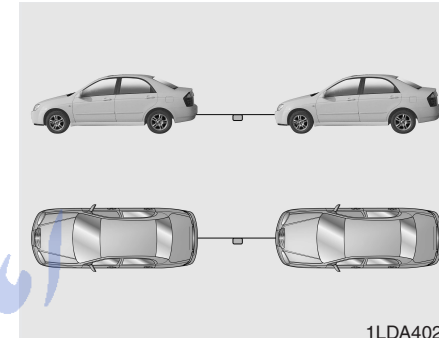

- Use a towing strap less than 5 m (16 feet) long. Attach a white or red cloth (about 30 cm (12 inches) wide) in the middle of the strap for easy visibility.
- Drive carefully so that the towing strap is not loosened during towing.



1

When your vehicle is being towed by another vehicle other than a tow truck (in case of an emergency)

- Turn the ignition switch to ACC so the steering wheel isn't locked.
- Place the transaxle shift lever in N (Neutral).
- Release the parking brake.
- Vehicles equipped with automatic transaxles should not exceed 45 km/h (28 mph) and should not be towed more than 80 km (50 miles).
- Vehicles equipped with manual transaxle should not be towed in excess of 88 km/h (55 mph) and should not be towed more than 645 km (400 miles).

2

3

4

5

6

7

8

9

- Press the brake pedal with more force than normal since you will have reduced brake performance.
- More steering effort will be required because the power steering system will be disabled.
- If you are driving down a long hill, the brakes may overheat and brake performance will be reduced. Stop often and let the brakes cool off.

*** NOTICE**

To prevent internal damage to the transaxle, never tow your vehicle from the rear (backwards) with all four tyres in contact with the surface.

Tips for towing a stuck vehicle

The following methods are effective when your vehicle is stuck in mud, sand or similar substances that prevent the vehicle from being driven out under its own power.

- Remove the soil and sand, etc. from the front and the back of the tyres.
- Place a stone or wood under the tyres.

IF YOU HAVE A FLAT TYRE

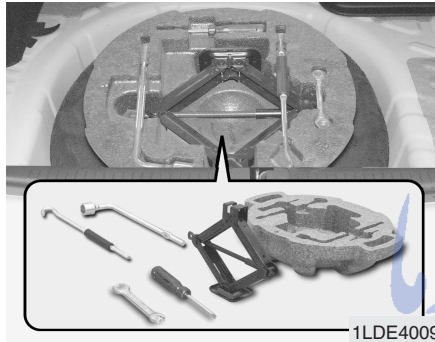

The spare tyre, jack, jack handle, wheel lug nut wrench are stored in the trunk compartment. Move the carpeting out of the way to reach this equipment.



Removing the spare tyre

Turn the tyre hold-down wing bolt counterclockwise.

Store the tyre in the reverse order of removal.

To prevent the spare tyre and tools from “rattling” while the vehicle is in motion, store them properly.

Changing tyres

Jacking instructions

The jack is provided for emergency tyre changing only.

Follow jacking instructions to reduce the possibility of personal injury.

1

2

3

4

5

6

7

8

9

FarmaSOS.com

1

2

3

4

5

6

7

8

9

⚠ WARNING - Changing tyres

- Never attempt vehicle repairs in the traffic lanes of a public road or highway.
- Always move the vehicle completely off the road and onto the shoulder before trying to change a tyre. The jack should be used on level firm ground whenever possible. If you cannot find a firm, level place off the road, call a towing service company for assistance.
- Do not exceed the jack's maximum permissible load: 700 kg (1,540 lbs.).
- Be sure to use the correct front and rear jacking positions on the vehicle; never use the bumpers or any other part of the vehicle for jack support.

(Continued)

(Continued)

- The vehicle can easily roll off the jack causing serious injury or death. No person should place any portion of their body under a vehicle that is supported only by a jack ; use vehicle support stands.
- Do not start or run the engine while the vehicle is on the jack.
- Do not allow anyone to remain in the vehicle while it is on the jack.
- Make sure any children present are in a secure place away from the road and from the vehicle to be raised with the jack.



Tyre replacement

1. Park on a level surface and apply the parking brake firmly.
2. Shift the shift lever into R (Reverse) with manual transaxle or P (Park) with automatic transaxle.
3. Activate the hazard warning flasher.



4. Remove the wheel lug nut wrench, jack, jack handle, and spare tyre from the vehicle.
5. Block both the front and rear of the wheel that is diagonally opposite the jack position.

⚠ WARNING - Changing a tyre

- To prevent vehicle movement while changing a tyre, always set the parking brake fully, and always block the wheel diagonally opposite the wheel being changed.
- It is recommended that the wheels of the vehicle be chocked, and that no person should remain in a vehicle that is being jacked.

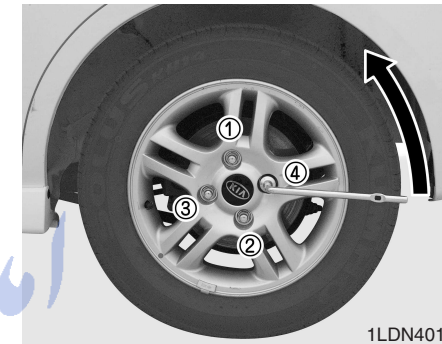

6. Loosen the wheel lug nuts counterclockwise one turn each, but do not remove any nut until the tyre has been raised off the ground.

- 1
- 2
- 3
- 4
- 5
- 6
- 7
- 8
- 9

In case of an emergency

1



2

3

4

5

6

7

8

9

7. Place the jack at the front or rear jacking position closest to the tyre you are changing. Place the jack at the designated locations under the frame. The jacking positions are plates welded to the frame with two tabs and a raised dot to index with the jack.

⚠ WARNING - Jack location

To reduce the possibility of injury, be sure to use only the jack provided with the vehicle and in the correct jack position; never use any other part of the vehicle for jack support.



8. Insert the jack handle into the jack and turn it clockwise, raising the vehicle until the tyre just clears the ground. This measurement is approximately 30 mm (1.2 in). Before removing the wheel lug nuts, make sure the vehicle is stable and that there is no chance for movement or slippage.
9. Remove the wheel lug nuts by turning them counterclockwise, then remove the wheel.
10. Mount the spare tyre into position and install the wheel lug nuts with the beveled edge inward.



11. Once the wheel lug nuts have been tightened, lower the vehicle fully to the ground and continue to tighten the lug nuts until they are fully secured. Tighten the wheel lug nuts firmly in a “X” pattern.

If you are unsure of the tightness of the wheel lug nuts, have them checked at the nearest service station. The specified tightening torque is 9~11 kg•m (65-79 lb•ft, 88-107 N•m). Improperly tightened wheel lug nuts could cause brake pedal vibration while braking.

CAUTION

Your vehicle has metric threads on the wheel studs and nuts. Make certain during wheel removal that the same nuts removed are reinstalled - or, if replaced, that nuts with metric threads and the same chamfer configuration are used. Installation of a non-metric thread nut on a metric stud or vice-versa will not secure the wheel to the hub properly and will damage the stud so that it must be replaced.

Note that most lug nuts do not have metric threads. Be sure to use extreme care in checking for thread style before installing aftermarket lug nuts or wheels. If in doubt, consult an Authorized Kia Dealer.

WARNING - Wheel studs

If the studs are damaged, they may lose their ability to retain the wheel. This could lead to the loss of the wheel and a collision.

To prevent the jack, jack handle, wheel lug nut wrench and spare tyre from rattling while the vehicle is in motion, store them properly.

WARNING

Check the inflation pressures as soon as possible after installing the spare tyre. Adjust it to the specified pressure, if necessary. Refer to Section 8, Specifications.

- 1
- 2
- 3
- 4
- 5
- 6
- 7
- 8
- 9

Maintenance services / 7-3	1
Normal maintenance schedule / 7-5	
Maintenance under severe usage conditions / 7-11	
Owner maintenance / 7-13	2
Engine compartment / 7-16	
Engine oil and oil filter / 7-19	3
Engine cooling system / 7-22	
Brakes and clutch / 7-25	
Parking brake / 7-26	4
Drive belts / 7-27	
Power steering / 7-28	
Steering wheel / 7-29	5
Manual transaxle / 7-30	
Automatic transaxle / 7-32	6
Lubricants and fluids / 7-35	
Maintenance	7
Fuel filter / 7-36	8
Air cleaner / 7-37	
Air conditioner air filter / 7-39	
Wiper blades / 7-41	9

1	Battery / 7-43
2	Tyres and wheels / 7-46
3	Bulb replacement / 7-53
4	Lubricant specifications / 7-60
5	Exterior care / 7-62
6	Interior care / 7-66
7	Maintenance
8	
9	

امداد خودرو فارما

تلفن شبانه روزی: ۰۲۱-۸۸۸۶۲۰۸۵

FarmaSOS.com

MAINTENANCE SERVICES

You should exercise the utmost care to prevent damage to your vehicle and injury to yourself whenever performing any maintenance or inspection procedures.

Should you have any doubts concerning the inspection or servicing of your vehicle, we strongly recommend that you have an Authorized Kia Dealer perform this work.

An Authorized Kia Dealer has factory-trained technicians and genuine Kia parts to service your vehicle properly. For expert advice and quality service, see an Authorized Kia Dealer.

Inadequate, incomplete or insufficient servicing may result in operational problems with your vehicle that could lead to vehicle damage, an accident, or personal injury.

Owner's responsibility

* NOTICE

Maintenance Service and Record Retention are the owner's responsibility.

You should retain documents that show proper maintenance has been performed on your vehicle in accordance with the scheduled maintenance service charts shown on the following pages. You need this information to establish your compliance with the servicing and maintenance requirements of your Kia warranties.

Detailed warranty information is provided in your Warranty & Maintenance book.

Repairs and adjustments required as a result of improper maintenance or a lack of required maintenance are not covered.

We recommend you have your vehicle maintained and repaired by an authorized Kia dealer.

An authorized Kia dealer meets Kia's high service quality standards and receives technical support from Kia in order to provide you with a high level of service satisfaction.

1

2

3

4

5

6

7

8

9

FarmaSOS.com

Scheduled maintenance service

1

Follow Normal Maintenance Schedule if the vehicle is usually operated where none of the following conditions apply. If any of the following conditions apply, follow Maintenance Under Severe Usage Conditions.

2

3

- Repeated short distance driving.

4

- Driving in dusty conditions or sandy areas.

5

- Extensive use of brakes.

6

- Driving in areas where salt or other corrosive materials are being used.

7

- Driving on rough or muddy roads.

8

- Driving in mountainous areas.

9

- Extended periods of idling or low speed operation.

- Driving for a prolonged period in cold temperatures and/or extremely humid climates.

- More than 50% driving in heavy city traffic during hot weather above 32°C (90°F).

If your vehicle is operated under the above conditions, you should inspect, replace or refill more frequently than the following Normal Maintenance Schedule. After 96 month or 120,000 km (80,000 miles) continue to follow the prescribed maintenance intervals.

امداد خودرو فارما

تلفن شبانه روزی: ۰۸۵-۸۸۸۶۲-۲۱

FarmaSOS.com

NORMAL MAINTENANCE SCHEDULE - FOR AUSTRALIA

MAINTENANCE ITEM	MAINTENANCE INTERVALS	Number of months or driving distance, whichever comes first								
		Months	12	24	36	48	60	72	84	96
		Km×1,000	15	30	45	60	75	90	105	120
Drive belts ¹		I	I	I	I	I	I	I	I	I
Engine oil and engine oil filter ²		R	R	R	R	R	R	R	R	R
Engine timing belt					I		R			
Air cleaner element		I	R	I	R	I	R	I	R	
Spark plugs			R		R		R		R	
Valve clearance		Inspect every 90,000 km or 48 months								
Vapor hose and fuel filler cap			I		I		I		I	
Vacuum and crankcase ventilation hoses			I		I		I		I	
Fuel filter					R				R	
Fuel lines and hoses		I	I	I	I	I	I	I	I	I

I : Inspect and if necessary, adjust, correct, clean or replace.

R : Replace or change.

¹ : Adjust alternator and power steering (and water pump drive belt) and air conditioner drive belt (if equipped).
Inspect and if necessary correct or replace.

² : Check the engine oil level and leak every 500 km or before starting a long trip.

1

2

3

4

5

6

7

8

9

Maintenance

NORMAL MAINTENANCE SCHEDULE - FOR AUSTRALIA (cont.)

MAINTENANCE ITEM	MAINTENANCE INTERVALS	Number of months or driving distance, whichever comes first								
		Months	12	24	36	48	60	72	84	96
		Km×1,000	15	30	45	60	75	90	105	120
1	2	3	Cooling system* ³ (including hoses and cap)							
		Inspect "Coolant level adjustment and leak" every day								
		Inspect "Water pump" when replacing the drive belt or timing belt								
3	Engine coolant* ⁴		At first, replace at 90,000 km or 60 months: after that, replace every 45,000 km or 24 months							
4	Battery condition		I	I	I	I	I	I	I	
5	All electrical systems (including the light bulbs and switches)		I	I	I	I	I	I	I	
6	Brake lines, hoses and connections		I	I	I	I	I	I	I	
7	Brake pedal, clutch pedal		I	I	I	I	I	I	I	
8	Parking brake		I	I	I	I	I	I	I	
9	Brake/clutch fluid		I	R	I	R	I	R	I	
	Disc brakes and pads		I	I	I	I	I	I	I	
	Drum brakes and linings		I	I	I	I	I	I	I	

I : Inspect and if necessary, adjust, correct, clean or replace.

R : Replace or change.

*³ : Inspect the cooling system every 500 km or before starting a long trip.

*⁴ : When adding coolant, use only a qualified coolant additive for your vehicle and never mix hard water in the coolant filled at the factory. An improper coolant mixture can result in serious malfunction or engine damage.

NORMAL MAINTENANCE SCHEDULE - FOR AUSTRALIA (cont.)

MAINTENANCE ITEM	MAINTENANCE INTERVALS	Number of months or driving distance, whichever comes first								
		Months	12	24	36	48	60	72	84	96
		Km×1,000	15	30	45	60	75	90	105	120
Power steering fluid and hoses		I	I	I	I	I	I	I	I	I
Steering gear rack, linkage and boots		I	I	I	I	I	I	I	I	I
Drive shaft and boots		I	I	I	I	I	I	I	I	I
Tyre (pressure & tread wear)		I	I	I	I	I	I	I	I	I
Front suspension		I	I	I	I	I	I	I	I	I
Bolt and nuts on chassis and body		I	I	I	I	I	I	I	I	I
Air conditioner sytem and refrigerant (if equipped)		I	I	I	I	I	I	I	I	I
Air conditioner air filter (if equipped)		R	R	R	R	R	R	R	R	R
Manual transaxle fluid		I	I	I	I	I	I	I	I	I
Automatic transaxle fluid		I	I	I	I	I	R	I	I	I

I : Inspect and if necessary, adjust, correct, clean or replace.

R : Replace or change.

FarmaSOS.com

1

2

3

4

5

6

7

8

9

Maintenance

NORMAL MAINTENANCE SCHEDULE - EXCEPT AUSTRALIA

MAINTENANCE INTERVALS		Number of months or driving distance, whichever comes first								
		Months	12	24	36	48	60	72	84	96
1 MAINTENANCE ITEM		Miles×1,000	10	20	30	40	50	60	70	80
		Km×1,000	15	30	45	60	75	90	105	120
	2 Drive belts ^{*1}	Gasoline	I	I	I	I	I	I	I	I
	Diesel		I		I		I		I	
3 Engine oil and engine oil filter ^{*2}	Gasoline		R	R	R	R	R	R	R	R
		For Europe	R	R	R	R	R	R	R	R
	Diesel	Except Europe	Replace every 10,000 km (6,000 miles) or 12 months							
4 Engine timing belt	Gasoline				I		R			
	Diesel				I				R	
5 Air cleaner element		I	R	I	R	I	R	I	R	
6 Spark plugs (Gasoline)	For Europe		R		R		R		R	
	Except Europe	Replace every 40,000 km (25,000 miles)								
7 Valve clearance	2.0L Gasoline	Inspect every 90,000 km (60,000 miles) or 48 months								
8 Vapor hose and fuel filler cap			I		I		I		I	
9 Vacuum and crankcase ventilation hoses			I		I		I		I	
Fuel filter	Gasoline				R				R	
	Diesel		R		R		R		R	
Fuel lines and hoses		I	I	I	I	I	I	I	I	

I : Inspect and if necessary, adjust, correct, clean or replace.

R : Replace or change.

^{*1} : Adjust alternator and power steering (and water pump drive belt) and air conditioner drive belt (if equipped).
Inspect and if necessary correct or replace.

^{*2} : Check the engine oil level and leak every 500 km (350 miles) or before starting a long trip.

NORMAL MAINTENANCE SCHEDULE - EXCEPT AUSTRALIA (cont.)

MAINTENANCE ITEM	MAINTENANCE INTERVALS	Number of months or driving distance, whichever comes first								
		Months	12	24	36	48	60	72	84	96
		Miles×1,000	10	20	30	40	50	60	70	80
		Km×1,000	15	30	45	60	75	90	105	120
Cooling system		Inspect "Coolant level adjustment and leak" every day								
		Inspect "Water pump" when replacing the drive belt or timing belt								
Engine coolant	For Europe ^{*3}	At first, replace at 90,000 km (60,000 miles) or 60 months: after that, replace every 45,000 km (30,000 miles) or 24 months								
	Except Europe	Replace every 45,000 km (30,000 miles) or 24 months								
Battery condition		I	I	I	I	I	I	I	I	
All electrical systems			I		I		I		I	
Brake lines, hoses and connections		I	I	I	I	I	I	I	I	
Brake pedal, clutch pedal							I		I	
Parking brake			I		I		I		I	
Brake/clutch fluid	For Europe	I	R	I	R	I	R	I	R	
	Except Europe	I	I	I	I	I	I	I	I	
Disc brakes and pads		I	I	I	I	I	I	I	I	
Drum brakes and linings			I		I		I		I	

I : Inspect and if necessary, adjust, correct, clean or replace.

R : Replace or change.

^{*3} : When adding coolant, use only a qualified coolant additive for your vehicle and never mix hard water in the coolant filled at the factory. An improper coolant mixture can result in serious malfunction or engine damage.

1

2

3

4

5

6

7

8

9

Maintenance

NORMAL MAINTENANCE SCHEDULE - EXCEPT AUSTRALIA (cont.)

1 2 3 4 5 6 7 8 9	MAINTENANCE INTERVALS	Number of months or driving distance, whichever comes first								
		Months	12	24	36	48	60	72	84	96
		Miles×1,000	10	20	30	40	50	60	70	80
		Km×1,000	15	30	45	60	75	90	105	120
	Power steering fluid and hoses		I			I		I		I
	Steering gear rack, linkage and boots	I	I	I	I	I	I	I	I	I
	Drive shaft and boots		I				I			I
	Tyre (pressure & tread wear)	I	I	I	I	I	I	I	I	I
	Front suspension ball joints	I	I	I	I	I	I	I	I	I
	Bolt and nuts on chassis and body	I	I	I	I	I	I	I	I	I
	Air conditioner refrigerant (if equipped)	I	I	I	I	I	I	I	I	I
	Air conditioner compressor (if equipped)	I	I	I	I	I	I	I	I	I
	Air conditioner air filter (if equipped)	R	R	R	R	R	R	R	R	R
	Manual transaxle fluid	I	I	I	I	I	I	I	I	I
	Automatic transaxle fluid	For Europe	I	I	I	I	I	R	I	I
		Except Europe	I	I	I	I	I	I	I	I

I : Inspect and if necessary, adjust, correct, clean or replace.

R : Replace or change.

MAINTENANCE UNDER SEVERE USAGE CONDITIONS

The following items must be serviced more frequently on cars mainly used under severe driving conditions. Refer to the chart below for the appropriate maintenance intervals.

R : Replace I : Inspect and if necessary, adjust, correct, clean or replace

MAINTENANCE ITEM		Maintenance operation	Maintenance intervals	Driving condition
Engine oil and engine oil filter	Gasoline	R	Every 7,500 km (5,000 miles) or 6 months	A, B, C, F, G
	Diesel	R	Every 7,500 km (5,000 miles) or 6 months	A, B, C, F, H
Air cleaner element		I	Inspect more frequently depending on the condition	C, E
Spark plugs	Gasoline	I	Inspect more frequently depending on the condition	B, H
Engine timing belt	Gasoline	R	Every 60,000 km (40,000 miles) or 48 months	D, E, F, G
	Diesel	R	Every 60,000 km (40,000 miles) or 48 months	
Manual transaxle fluid	For Europe & Australia	R	Every 90,000 km (60,000 miles)	A, C, D, E, F, G, H, I, J
	Except Europe & Australia	R	Every 100,000 km (62,000 miles)	
Automatic transaxle fluid	For Europe & Australia	R	Every 45,000 km (30,000 miles)	A, C, E, F, G, H, I
	Except Europe & Australia	R	Every 40,000 km (25,000 miles)	
Steering gear rack, linkage and boots		I	Inspect more frequently depending on the condition	C, D, E, F, G
Front suspension ball joints		I	Inspect more frequently depending on the condition	C, D, E, F, G

1

2

3

4

5

6

7

8

9

Maintenance

	MAINTENANCE ITEM	Maintenance operation	Maintenance intervals	Driving condition
1	Disc brakes and pads, calipers and rotors	I	Inspect more frequently depending on the condition	C, D, E, G, H
2	Drum brakes and linings	I	Inspect more frequently depending on the condition	C, D, E, G, H
3	Parking brake	I	Inspect more frequently depending on the condition	C, D, G, H
4	Drive shaft and boots	I	Inspect more frequently depending on the condition	C, D, E, F
5	Air conditioner air filter (if equipped)	R	Replace more frequently depending on the condition	C, E

6

Severe driving conditions

7

A : Repeated short distance driving

B : Extensive idling

C : Driving in dusty, rough roads

8

D : Driving in areas using salt or other corrosive materials or in very cold weather

9

E : Driving in sandy areas

F : More than 50 % driving in heavy city traffic during hot weather above 32°C (90°F)

G : Driving in mountainous areas.

H : Towing a trailer

I : Driving for patrol car, taxi, commercial car or vehicle towing

J : Driving over 170km/h (106 mile/h)

OWNER MAINTENANCE

Owner maintenance schedule

The following lists are vehicle checks and inspections that should be performed by the owner or an Authorized Kia Dealer at the frequencies indicated to help ensure safe, dependable operation of your vehicle.

Any adverse conditions should be brought to the attention of your dealer as soon as possible.

These Owner Maintenance Checks are generally not covered by warranties and you may be charged for labor, parts and lubricants used.

When you stop for fuel:

- Check the engine oil level.
- Check coolant level in coolant reservoir.

⚠ WARNING

Be careful when checking your engine coolant level when the engine is hot. Scalding hot coolant and steam may blow out under pressure. This could cause serious injury.

- Check the windshield washer fluid level.
- Look for low or under-inflated tyres.

While operating your vehicle:

- Note any changes in the sound of the exhaust or any smell of exhaust fumes in the vehicle.
- Check for vibrations in the steering wheel. Notice any increased steering effort or looseness in the steering wheel, or change in its straight-ahead position.
- Notice if your vehicle constantly turns slightly or “pulls” to one side when traveling on smooth, level road.
- When stopping, listen and check for strange sounds, pulling to one side, increased brake pedal travel or “hard-to-push” brake pedal.
- If any slipping or changes in the operation of your transaxle occurs, check the transaxle fluid level.
- Check automatic transaxle P (Park) function.
- Check parking brake.
- Check for fluid leaks under your vehicle (water dripping from the air conditioning system after use is normal).

1

2

3

4

5

6

7

8

9

Maintenance

1

At least monthly:

- Check coolant level in the coolant recovery reservoir.
- Check the operation of all exterior lights, including the stoplights, turn signals and hazard warning flashers.
- Check the inflation pressures of all tyres including the spare.

2

3

4

5

6

7

8

9

At least twice a year (i.e., every Spring and Fall) :

- Check radiator, heater and air conditioning hoses for leaks or damage.
- Check windshield washer spray and wiper operation. Clean wiper blades with clean cloth dampened with washer fluid.
- Check headlight alignment.
- Check muffler, exhaust pipes, shields and clamps.
- Check the lap/shoulder belts for wear and function.
- Check for worn tyres and loose wheel lug nuts.

At least once a year :

- Clean body and door drain holes.
- Lubricate door hinges and checks, and hood hinges.
- Lubricate door and hood locks and latches.
- Lubricate door rubber weatherstrips.
- Check the air conditioning system before the warm weather season.
- Check the power steering fluid level.
- Inspect and lubricate automatic transaxle linkage and controls.
- Clean battery and terminals.
- Check the brake fluid level.

FarmaSOS.com

Owner maintenance precautions

Improper or incomplete service may result in problems. This section gives instructions only for the maintenance items that are easy to perform.

As explained earlier in this section, several procedures can be done only by an Authorized Kia Dealer with special tools.

* NOTICE

Improper owner maintenance during the warranty period may affect warranty coverage. For details, read the separate Kia Warranty & Maintenance book provided with the vehicle. If you're unsure about any servicing or maintenance procedure, have it done by an Authorized Kia Dealer.

⚠ WARNING - Maintenance work

- **Performing maintenance work on a vehicle can be dangerous. You can be seriously injured while performing some maintenance procedures. If you lack sufficient knowledge and experience or the proper tools and equipment to do the work, have it done by an Authorized Kia Dealer.**
- **Working under the hood with the engine running is dangerous. It becomes even more dangerous when you wear jewelry or loose clothing. These can become entangled in moving parts and result in injury. Therefore, if you must run the engine while working under the hood, make certain that you remove all jewelry (especially rings, bracelets, watches, and necklaces) and all neckties, scarves, and similar loose clothing before getting near the engine or cooling fans.**

1

2

3

4

5

6

7

8

9

ENGINE COMPARTMENT

■ 1.6L Gasoline Engine

- 1
- 2
- 3
- 4
- 5
- 6
- 7**
- 8
- 9

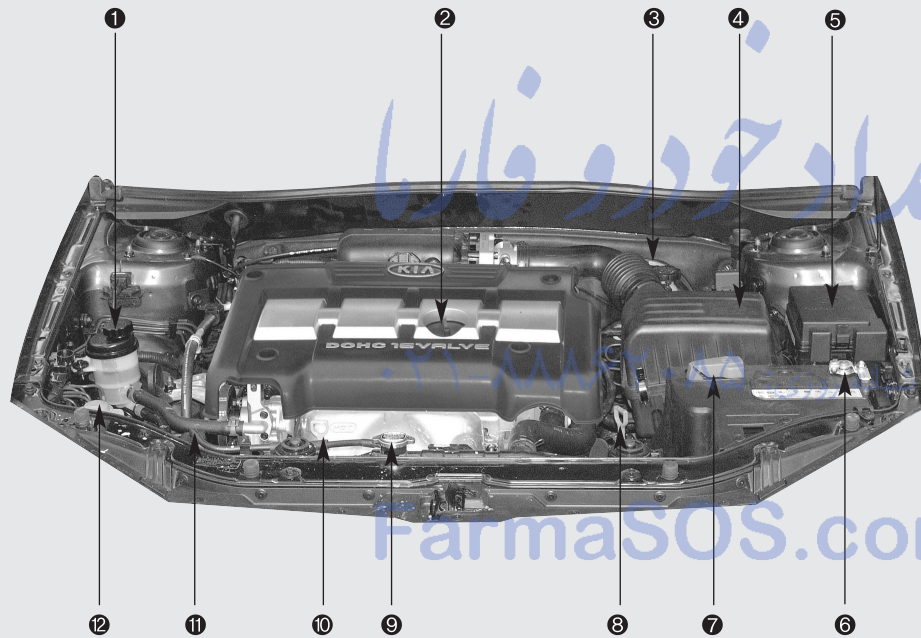

- 1. Power steering fluid reservoir
- 2. Engine oil filler cap
- 3. Brake fluid reservoir
- 4. Air cleaner
- 5. Fuse box
- 6. Negative battery terminal
- 7. Positive battery terminal
- 8. Auto transaxle oil dipstick (if equipped)
- 9. Radiator cap
- 10. Engine oil dipstick
- 11. Engine coolant reservoir
- 12. Windshield washer fluid reservoir

1LDE5001

■ 2.0L (CVVT) Gasoline Engine

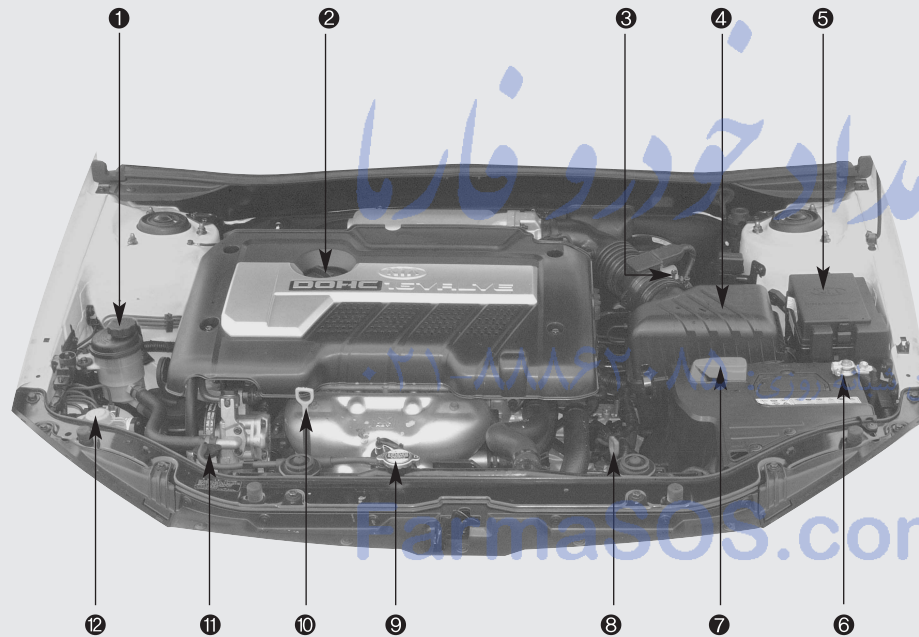

- 1. Power steering fluid reservoir
- 2. Engine oil filler cap
- 3. Brake fluid reservoir
- 4. Air cleaner
- 5. Fuse box
- 6. Negative battery terminal
- 7. Positive battery terminal
- 8. Auto transaxle oil dipstick (if equipped)
- 9. Radiator cap
- 10. Engine oil dipstick
- 11. Engine coolant reservoir
- 12. Windshield washer fluid reservoir

- 1
- 2
- 3
- 4
- 5
- 6
- 7**
- 8
- 9

1LDA5002

■ 2.0L Diesel Engine

- 1
- 2
- 3
- 4
- 5
- 6
- 7**
- 8
- 9

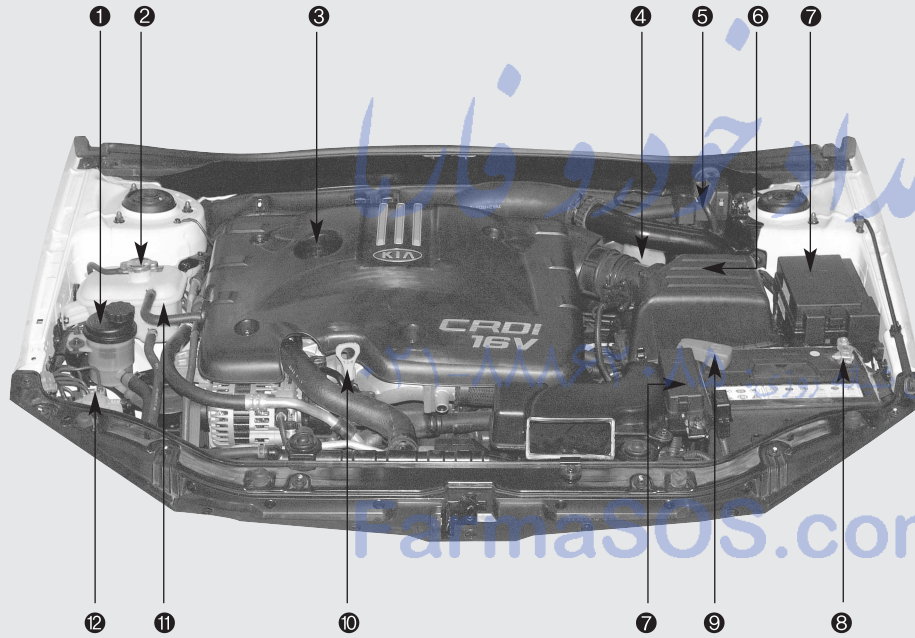

- 1. Power steering fluid reservoir
- 2. Radiator cap
- 3. Engine oil filler cap
- 4. Brake fluid reservoir
- 5. Fuel filter
- 6. Air cleaner
- 7. Fuse box
- 8. Negative battery terminal
- 9. Positive battery terminal
- 10. Engine oil dipstick
- 11. Engine coolant reservoir
- 12. Windshield washer fluid reservoir

1LDE5002

ENGINE OIL AND OIL FILTER

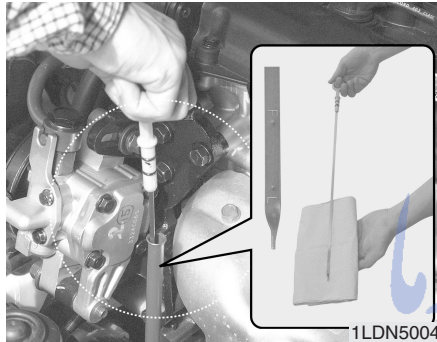

Checking the engine oil level

1. Be sure the vehicle is on level ground.
2. Start the engine and allow it to reach normal operating temperature.
3. Turn the engine off and wait for a few minutes (about 5 minutes) for the oil to return to the oil pan.
4. Pull the dipstick out, wipe it clean, and re-insert it fully.
5. Pull the dipstick out again and check the level. The level should be between F and L.

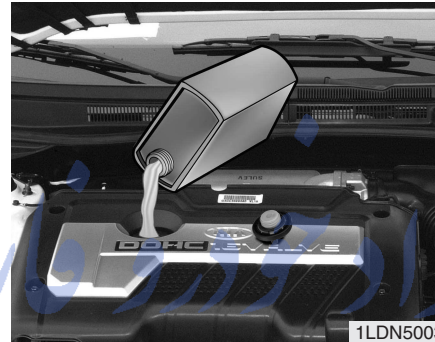

If it is near or at L, add enough oil to bring the level to F. **Do not overfill.**

Use only the specified engine oil. (Refer to "Recommended Lubricants" later in this section.)

Changing the engine oil and filter

Change engine oil and filter according to the Scheduled Maintenance at the beginning of this section.

⚠ WARNING

Used engine oil may cause irritation or cancer of the skin if left in contact with the skin for prolonged periods of time. Used engine oil contains chemicals that have caused cancer in laboratory animals. Always protect your skin by washing your hands thoroughly with soap and warm water as soon as possible after handling used oil.

1

2

3

4

5

6

7

8

9

FarmaSOS.com

1

1. Warm the engine up for a few minutes and then turn it off. Remove the oil filler cap.

2

2. Raise and suitably support the vehicle.

3

⚠ WARNING - Lifting your vehicle

If you raise your vehicle, always ensure that it is supported at all four jacking or lift points for the vehicle. Do not use jacks meant for tyre changes. Use only lift equipment specifically recommended for doing maintenance work under the vehicle. Place the vehicle and lift equipment on a hard, level surface capable of supporting the full weight of the vehicle without moving or deforming. If the support is not stable, the vehicle could fall and cause serious or fatal injuries. Follow the instructions with the lift device.

4

5

6

7

8

9

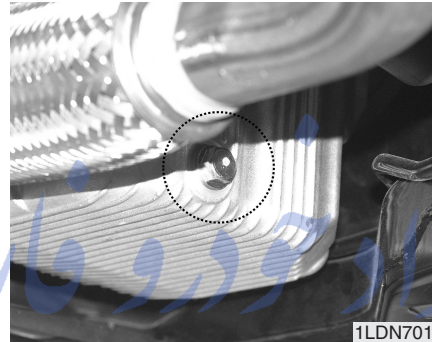

3. Drain the oil into a suitable container by removing the oil drain plug.

⚠ CAUTION

- Both the oil and engine are hot. Do not burn yourself.
- Keep all engine oil out of the reach of children.

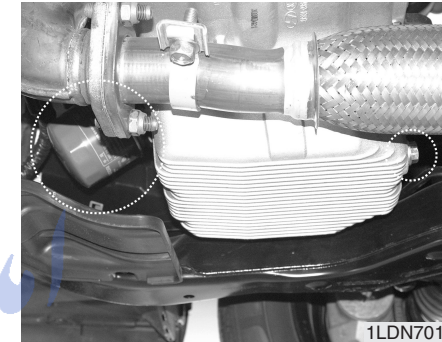

4. Remove the engine oil filter with an oil filter wrench.

*** NOTICE**

Do not allow the oil filter gasket to remain on the oil filter mounting surface. This will cause oil leakage and engine damage. Remove the old gasket completely so that a new gasket may be properly seated.

5. Use a clean rag to clean the oil filter mounting surface on the engine.

6. Apply a small amount of engine oil to the new oil filter O-ring seal.

7. Install the oil filter and tighten it. (Refer to the oil filter caution label for tightening instructions.)
8. Install a new washer on the drain plug. Don't use an old washer repeatedly.
9. Replace the drain plug after the oil has thoroughly drained. Torque the plug to 4.0~4.5 kg•m (28.9~32.5 lb•ft, 39.2~44.1 N•m).
10. Refill the engine with new oil to the F mark on the dipstick. Do not overfill.
11. Reinstall the oil filler cap securely.
12. Start the engine and inspect around the oil filter seal for leaks. Stop the engine.
13. Check the oil level and fill to the F mark as necessary.

Oil capacity

- 1.6 L Gasoline Engine
With filter change :
3.3 litres (3.5 US qt.)
Without filter change :
3.0 litres (3.2 US qt.)
- 2.0 L Gasoline Engine
With filter change :
4.0 litres (4.2 US qt.)
Without filter change :
3.7 litres (3.9 US qt.)
- 1.5 L Diesel Engine
With filter change :
5.3 litres (5.6 US qt.)
Without filter change :
4.8 litres (5.07 US qt.)
- 2.0 L Diesel Engine
With filter change :
5.9 litres (6.2 US qt.)
Without filter change :
5.4 litres (5.7 US qt.)

Use only the specified Service Grade engine oil. (Refer to "Recommended Lubricants" later in this section.)

* NOTICE

- Although oil filters may have the same external appearance, their internal designs differ significantly. These filters are not interchangeable. To avoid potential engine damage, use only the specified filter. Consult an Authorized Kia Dealer.
- Follow these instructions carefully. An improper oil filter installation can cause oil leakage and engine damage. Drained engine oil should be disposed of properly, according to local environmental protection agency codes. It should not be thrown down the drain or in the trash.

1

2

3

4

5

6

7

8

9

ENGINE COOLING SYSTEM

The high-pressure cooling system has a reservoir filled with year-round antifreeze coolant. The reservoir is filled at the factory.

Check the antifreeze protection and coolant level at least once a year, at the beginning of the winter season, and before traveling to a colder climate.

1

2

3

4

5

6

7

8

9

Checking the coolant level

⚠ WARNING - Removing radiator cap

- Never attempt to remove the radiator cap while the engine is operating or hot. Doing so might lead to cooling system and engine damage and could result in serious personal injury from escaping hot coolant or steam.
- Turn the engine off and wait until it cools down. Even then, use extreme care when removing the radiator cap. Wrap a thick towel around it, and turn it counterclockwise slowly to the first stop. Step back while the pressure is released from the cooling system. When you are sure all the pressure has been released, press down on the cap, using a thick towel, and continue turning counterclockwise to remove it.

(Continued)

(Continued)

- Even if the engine is not operating, do not remove the radiator cap or the drain plug while the engine and radiator are hot. Hot coolant and steam may still blow out under pressure, causing serious injury.

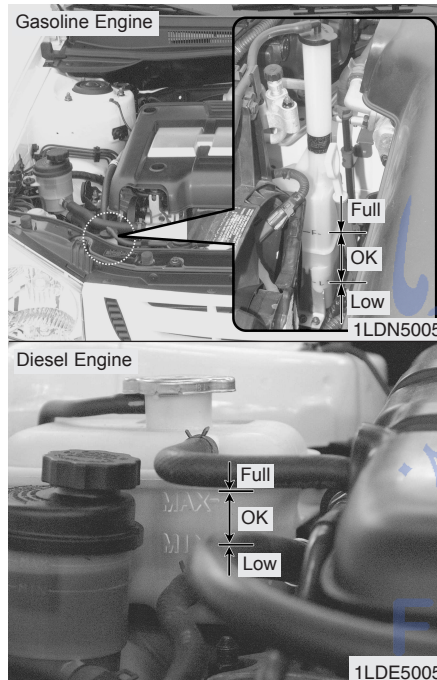

The coolant level should be filled between F and L marks on the side of the coolant reservoir when the engine is cool.

If the coolant level is low, add enough specified coolant to provide protection against freezing and corrosion. Bring the level to F, but do not over-fill. If frequent additions are required, see an Authorized Kia Dealer for a cooling system inspection.

Changing coolant

Change coolant according to the Maintenance Schedule.

- Use only soft (de-mineralized) water in the coolant mixture.
- The engine in your vehicle has aluminum engine parts and must be protected by an ethylene-glycol-based coolant to prevent corrosion and freezing.
- DO NOT USE alcohol or methanol coolant or mix them with the specified coolant.

Check the condition and connections of all cooling system hoses and heater hoses. Replace any swollen or deteriorated hoses.

- Do not use a solution that contains more than 60% antifreeze or less than 35% antifreeze, which would reduce the effectiveness of the solution.

For mixture percentage, refer to the following table.

Ambient Temperature	Mixture Percentage (volume)	
	Coolant Solution	Water
-15°C (5°F)	35	65
-25°C (-13°F)	40	60
-35°C (-31°F)	50	50
-45°C (-49°F)	60	40

- 1
- 2
- 3
- 4
- 5
- 6
- 7
- 8
- 9

- 1
- 2
- 3
- 4
- 5
- 6
- 7
- 8
- 9



⚠ WARNING
 Do not remove the radiator cap when the engine and radiator are hot. Scalding hot coolant and steam may blow out under pressure. This could cause serious injury.

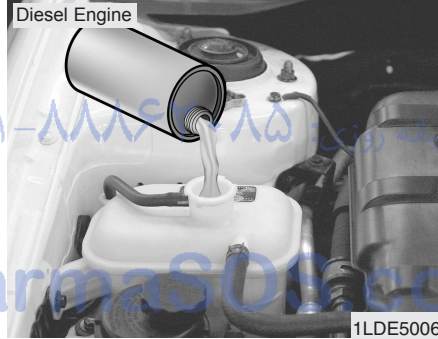
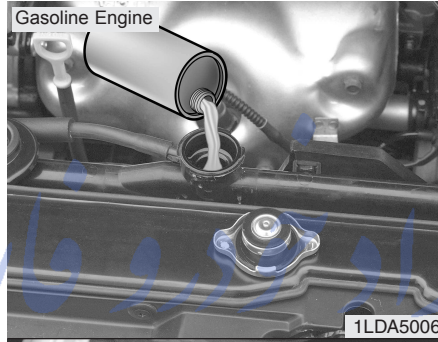

1. Turn the radiator cap counter-clockwise to remove it.
2. Loosen the radiator drain plug and drain the coolant into a suitable container.

3. With the plug loose, flush the system with running water.
4. Drain the system completely and retighten the drain plug. Add the necessary amount of ethylene-glycol based coolant and water to provide the required protection against freezing and corrosion. In extremely cold climates, add ethylene-glycol based coolant in accordance with the instructions of the manufacturer.
5. Run the engine at idle with the radiator cap off. Slowly add additional coolant as necessary.
6. At this point, wait until the engine reaches normal operating temperature. Depress the accelerator two or three times; then add coolant as required. **Be careful not to burn yourself.**
7. Reinstall the radiator cap. Inspect all connections for leaks and recheck the coolant level in the reservoir. Recheck again after a few days and add coolant as necessary.

BRAKES AND CLUTCH (IF EQUIPPED)**Checking brake/clutch fluid level**

Check the fluid level in the reservoir periodically. The fluid level should be between MAX and MIN marks on the side of the reservoir.

Before removing the reservoir cap and adding brake/clutch fluid, clean the area around the reservoir cap thoroughly to prevent brake/clutch fluid contamination.

If the level is low, add fluid to the MAX level. The level will fall with accumulated mileage. This is a normal condition associated with the wear of the brake linings. If the fluid level is excessively low, have the brake system checked by an Authorized Kia Dealer.

Use only the specified brake/clutch fluid. (Refer to "Recommended Lubricants" later in this section.)

Never mix different types of fluid.

⚠ WARNING

In the event the brake system requires frequent additions of fluid, the vehicle should be inspected by an Authorized Kia Dealer.

⚠ WARNING

When changing and adding brake/clutch fluid, handle it carefully. Do not let it come in contact with your eyes. If brake/clutch fluid should come in contact with your eyes, immediately flush them with a large quantity of fresh tap water. Have your eyes examined by a doctor as soon as possible.

1

2

3

4

5

6

7

8

9

1

2

3

4

5

6

7

8

9

CAUTION

Do not allow brake/clutch fluid to contact the vehicle's body paint, as paint damage will result. Brake/clutch fluid, which has been exposed to open air for an extended time should never be used as its quality cannot be guaranteed. It should be thrown out. Don't put in the wrong kind of fluid. For example, just a few drops of mineral-based oil, such as engine oil, in your brake clutch system can damage brake clutch system parts.

PARKING BRAKE

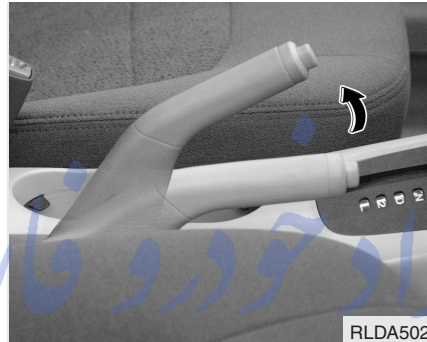

Checking the parking brake

Check the stroke of the parking brake by counting the number of “clicks” heard while fully applying it from the released position. Also, the parking brake alone should securely hold the vehicle on a fairly steep grade. If the stroke is more or less than specified, have the parking brake adjusted by an Authorized Kia Dealer.

Stroke : 7~8 “clicks” at a force of 20 kg (44 lbs, 196 N).

DRIVE BELTS

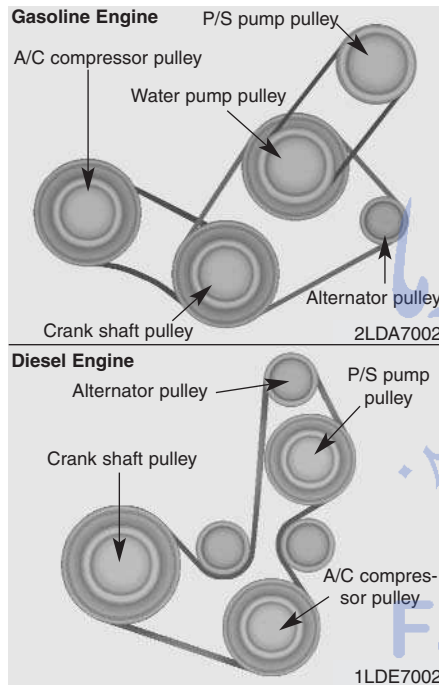

Drive belts should be checked periodically for proper tension and adjusted if necessary. At the same time, belts should be examined for cracks, wear, fraying or other evidence of deterioration and replaced if necessary.

Belt routing should also be checked to be sure there is no interference between the belts and other parts of the engine. After a belt is replaced, the new belt should be adjusted again after two or three weeks to eliminate slack resulting from initial stretching after use.

Checking the compressor drive belt

When the air conditioning is being used regularly, the compressor drive belt tension should be checked at least once a month.

To check the drive belt tension, turn the engine off, press down on the belt halfway between the engine crankshaft and compressor pulleys. Pressing with your finger, you should not be able to deflect this belt any more than 8.5 mm (0.33 in). If you have the instruments to check it, with a force of 98 N (22 lb.), the deflection should be 8.0 mm (0.315 in). If the belt is too loose, have it adjusted by an authorized Kia Dealer.

- 1
- 2
- 3
- 4
- 5
- 6
- 7
- 8
- 9

شبهانه روزی: ۰۲۱-۸۸۸۶۲۰۸۵
 FarmaSOS.com

POWER STEERING

1

2

3

4

5

6

7

8

9



Checking the power steering fluid level

With the vehicle on level ground, check the fluid level in the power steering reservoir periodically. The fluid should be between MAX and MIN marks on the side of the reservoir at the normal temperature.

Before adding power steering fluid, thoroughly clean the area around the reservoir cap to prevent power steering fluid contamination.

If the level is low, add fluid to the MAX level.

In the event the power steering system requires frequent addition of fluid, the vehicle should be inspected by an Authorized Kia Dealer.

Power steering hose

Check the connections for oil leaks, severe damage and the twists in the power steering hose before driving.

* NOTICE

- To avoid damage to the power steering pump, do not operate the vehicle for prolonged periods with a low power steering fluid level.
- Never start the engine when the reservoir tank is empty.
- When adding fluid, be careful that dirt does not get into the tank.
- Too little fluid can make the steering wheel heavier or strange noise can be generated.
- The use of the non-specified fluid could reduce the effectiveness of the power steering wheel and cause damage to it.

Use only the specified power steering fluid. (Refer to "Recommended Lubricants" later in this section.)

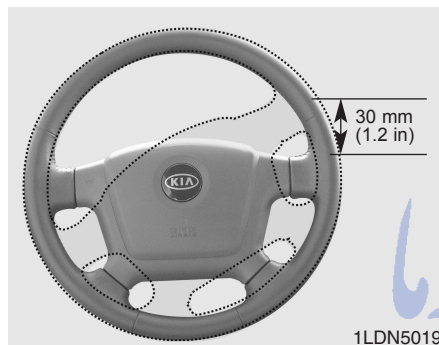
STEERING WHEEL

Park the vehicle on level ground, start the car and place the tyre wheels in the straight-ahead position. Turn the steering wheel to the left and right with a little force and check the free play until you get a feel for resistance against the tyre wheels movement.

Standard value: 30 mm (1.2 in) or less

*** NOTICE**

If the measured value exceeds the standard value, have the system checked by an authorized Kia dealer.

امداد خودرو فارما

تلفن شبانه روزی: ۰۸۵-۸۸۸۶۲-۱

FarmaSOS.com

1

2

3

4

5

6

7

8

9

MANUAL TRANSAXLE (IF EQUIPPED)

Checking the manual transaxle oil level

1

1. Raise and suitably support the vehicle.

2

⚠ WARNING - Lifting your vehicle

3

If you raise your vehicle, always ensure that it is supported at all four jacking or lift points for the vehicle. Do not use jacks meant for tyre changes. Use only lift equipment specifically recommended for doing maintenance work under the vehicle. Place the vehicle and lift equipment on a hard, level surface capable of supporting the full weight of the vehicle without moving or deforming. If the support is not stable, the vehicle could fall and cause serious or fatal injuries. Follow the instructions with the lift device.

4

5

6

7

8

9

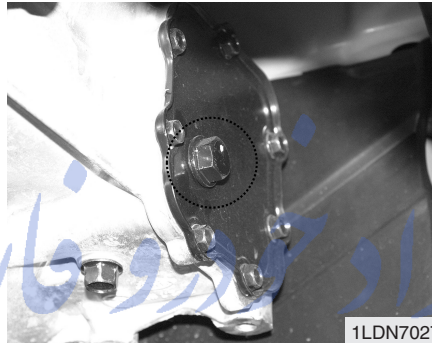

2. Remove the fill/check plug on the side of the transaxle.

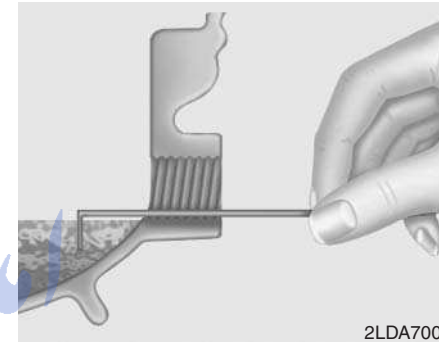

3. Verify that the oil level reaches the bottom of the fill/check hole. Fill as necessary.

If the oil level is low, check for leaks before adding oil. Do not overfill. Use only the specified manual transaxle oil. (Refer to "Recommended Lubricants" later in this section.)

4. Install a new washer on the fill/check plug and tighten the plug to 3.0~3.5 kg•m (22~25 lb•ft, 30~35 N•m) - Gasoline Engine and 3.5~4.5 kg•m (25~33 lb•ft, 35~45 N•m) - Diesel Engine.

Changing the manual transaxle oil

1. Raise and suitably support the vehicle.

⚠ WARNING - Lifting your vehicle

If you raise your vehicle, always ensure that it is supported at all four jacking or lift points for the vehicle. Do not use jacks meant for tyre changes. Use only lift equipment specifically recommended for doing maintenance work under the vehicle. Place the vehicle and lift equipment on a hard, level surface capable of supporting the full weight of the vehicle without moving or deforming. If the support is not stable, the vehicle could fall and cause serious or fatal injuries. Follow the instructions with the lift device.

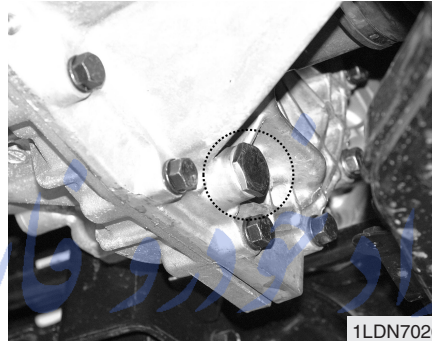

2. Remove the drain plug on the bottom of the transaxle.
3. After the oil has drained completely, install a new washer on the plug, reinstall the drain plug and tighten to 3.0~3.5 kg•m (22~25 lb•ft, 30~35 N•m).

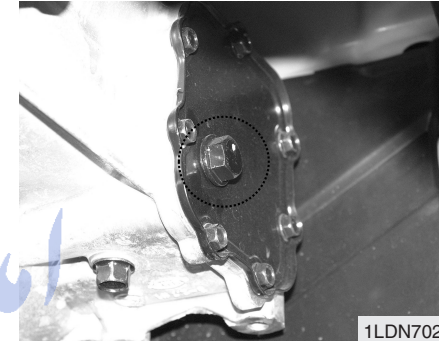

4. Remove the fill/check plug on the side of the transaxle.
5. Add oil through the fill/check hole until it reaches the bottom of the fill/check hole.
6. Install a new washer on the fill/check plug.
7. Reinstall and tighten the fill/check plug to 3.0~3.5 kg•m (22~25 lb•ft, 30~35 N•m) - Gasoline Engine and 3.5~4.5 kg•m (25~33 lb•ft, 35~45 N•m) - Diesel Engine.

Use only the specified manual transaxle oil. (Refer to "Recommended Lubricants" later in this section.)

1

2

3

4

5

6

7

8

9

AUTOMATIC TRANSAXLE (IF EQUIPPED)

- 1
- 2
- 3
- 4
- 5
- 6
- 7**
- 8
- 9



Checking the automatic transaxle fluid level

The automatic transaxle fluid level should be checked regularly.

The volume of the transaxle fluid changes with temperature. Although it is best to check the level after having driven the vehicle for at least 30 minutes, the level can be checked after warming the fluid using the following procedure.

1. Park the vehicle on level ground and firmly apply the parking brake.
2. Allow the engine to idle for about 2 minutes.
3. Depress the brake pedal and move the shift lever slowly through all ranges then set it in P (Park).
4. With the engine still idling, pull out the dipstick, wipe it clean and reinsert it fully.
5. Pull out the dipstick again and check the fluid level.

CAUTION

- *Low fluid level causes transaxle slippage. Overfilling can cause foaming, loss of fluid and transaxle malfunction.*
- *The use of a non-specified fluid could result in transaxle malfunction and failure.*

WARNING - Parking brake
To avoid sudden movement of the vehicle, apply parking brake and depress the brake pedal before moving the shift lever.

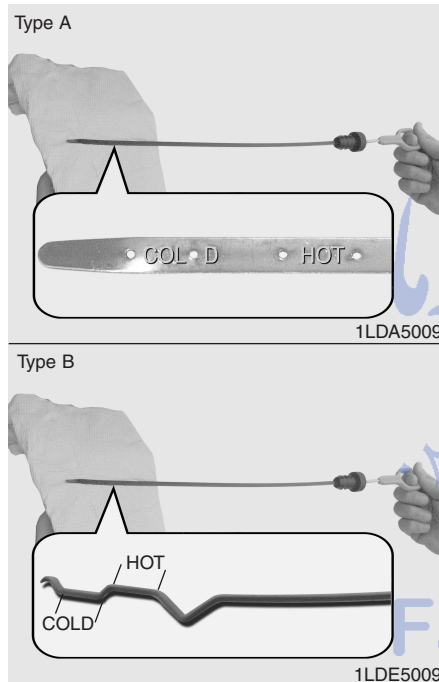

If the fluid has been warmed to normal operating temperature of approximately 70~80°C (158~176°F), the fluid level should be within “HOT” range.

*** NOTICE**

“COLD” scale is for reference only and should NOT be used to determine transaxle fluid level.

*** NOTICE**

New automatic transaxle fluid should be red. The red dye is added so the assembly plant can identify it as automatic transaxle fluid and distinguish it from engine oil or antifreeze. The red dye, which is not an indicator of fluid quality, is not permanent. As the vehicle is driven, the automatic transaxle fluid will begin to look darker. The colour may eventually appear light brown. Therefore, have an Authorized Kia dealer change the automatic transaxle fluid according to the Scheduled Maintenance at the beginning of this section.

Changing the automatic transaxle fluid

1. Raise and suitably support the vehicle.

⚠ WARNING - Lifting your vehicle

If you raise your vehicle, always ensure that it is supported at all four jacking or lift points for the vehicle. Do not use jacks meant for tyre changes. Use only lift equipment specifically recommended for doing maintenance work under the vehicle. Place the vehicle and lift equipment on a hard, level surface capable of supporting the full weight of the vehicle without moving or deforming. If the support is not stable, the vehicle could fall and cause serious or fatal injuries. Follow the instructions with the lift device.

- 1
- 2
- 3
- 4
- 5
- 6
- 7
- 8
- 9

- 1
- 2
- 3
- 4
- 5
- 6
- 7
- 8
- 9

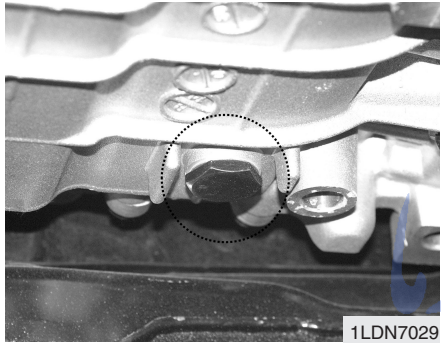

- 2. Remove the drain plug located at the bottom of the transaxle pan.
- 3. After the oil has drained completely, install a new washer on the plug, reinstall the drain plug, and tighten to 2.9~3.4 kg•m (21~24 lb•ft, 29~34 N•m).
- 4. Lower the vehicle.

- 5. Remove the automatic transaxle dipstick located near the centre of the engine compartment bulkhead and, using a funnel, add the necessary amount of automatic transaxle fluid.

Use only the specified automatic transaxle fluid. (Refer to "Recommended Lubricants" later in this section.)

*** NOTICE**

Do NOT overfill the automatic transaxle reservoir. Doing so can cause a seal "blow out", loss of fluid, and damage to the transaxle. If you overfill the reservoir, you must drain the excess prior to driving the vehicle. It is likely that there will be fluid left in the transaxle after draining, especially if the front of the vehicle was raised to remove the drain plug.

- 6. Check the fluid level. If necessary, add a small amount of fluid and check the level again. Continue this process until the level reads within "HOT" range.
- 7. Replace the dipstick and properly dispose of the used transaxle fluid.

LUBRICANTS AND FLUIDS



Checking the washer fluid level

The reservoir is translucent so that you can check the level with a quick visual inspection.

Check the fluid level in the washer fluid reservoir and add fluid if necessary. Plain water may be used if washer fluid is not available. However, use washer solvent with antifreeze characteristics in cold climates to prevent freezing.

⚠ WARNING

- Do not use radiator coolant or antifreeze in the washer fluid reservoir.
- Radiator coolant can severely obscure visibility when sprayed on the windshield and may cause loss of vehicle control or damage to paint and body trim.
- Windshield washer fluid agents contain some amounts of alcohol and can be flammable under certain circumstances. Do not allow sparks or flame to contact the washer fluid or the washer fluid reservoir. Damage to the vehicle or it's occupants could occur.
- Windshield washer fluid is poisonous to humans and animals. Do not drink and avoid contacting windshield washer fluid. Serious injury or death could occur.

Body lubrication

All moving points of the body, such as door hinges, hood hinges, and locks, should be lubricated each time the engine oil is changed. Use a non-freezing lubricant on locks during cold weather.

Make sure the engine hood secondary latch keeps the hood from opening when the primary latch is released.

1

2

3

4

5

6

7

8

9

1

FUEL FILTER (FOR DIESEL)

The fuel filter for diesel engine plays an important role of separating water from fuel and accumulating the water in its bottom.

2

If water accumulates in the fuel filter, the warning light comes on when the ignition key is in the "ON" position.

3

CAUTION

If the water accumulated in the fuel filter is not drained at proper times, damages to the major parts such as the fuel system can be caused by water permeation in the fuel filter.

4

5

6

7

8

9

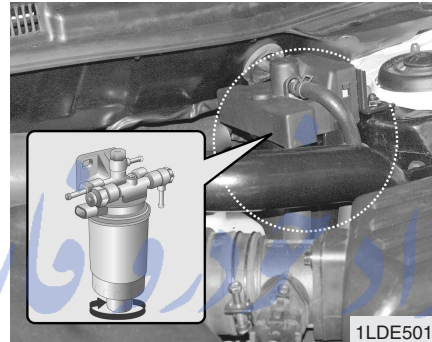

Draining water from the fuel filter

- Place a water tray under the fuel filter.
- Loosen the drain plug and drain water.
- After water is drained, securely tighten the drain plug.
- After starting the engine, check to make certain the fuel filter warning light is off.

AIR CLEANER



1LDA5010

Element cleaning

This element may be air cleaned or replaced, depending on its condition. Unless it is very dirty, merely shake it to remove foreign particles. Each time this filter is inspected, wipe the inside of the air cleaner housing and cover with a damp cloth. If the vehicle is operated in extremely dusty or sandy areas, clean or replace this element more often than at the usual recommended intervals.

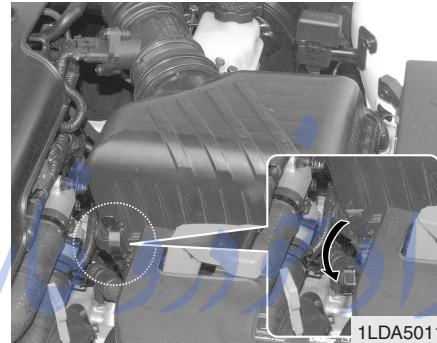

1LDA5011

Element replacement

A dry paper air cleaner filter is used. It must be replaced when necessary.

1. Loosen the air cleaner cover attaching clips and open the cover.

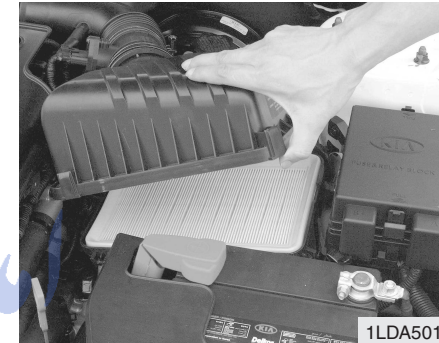

1LDA5012

2. Wipe the inside of the air cleaner housing with a clean, damp cloth.

1

2

3

4

5

6

7

8

9

armaSOS.com

- 1
- 2
- 3
- 4
- 5
- 6
- 7**
- 8
- 9

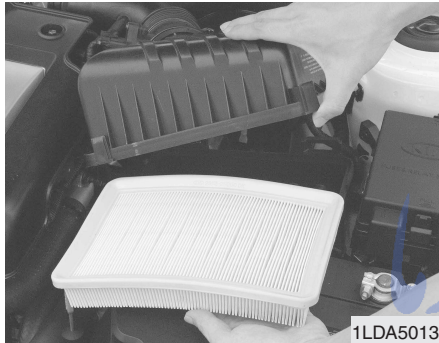

- 3. Replace the air cleaner element. We recommend that the air cleaner element be replaced with genuine Kia parts.
- 4. Lock the cover with the cover attaching clips.

Replace the element according to the Scheduled Maintenance Section.

If the vehicle is operated in extremely dusty or sandy areas, replace the element more often than the usual recommended intervals. (Refer to Maintenance Under Severe Usage Conditions in this section.)

CAUTION

- **Do not drive with the air cleaner removed; this will result in excessive engine wear.**
- **Driving without an air cleaner encourages backfiring, which could cause a fire in the engine compartment.**
- **When removing the air cleaner element, be careful that dust or dirt does not enter the air intake, or damage may result.**

AIR CONDITIONER AIR FILTER (IF EQUIPPED)

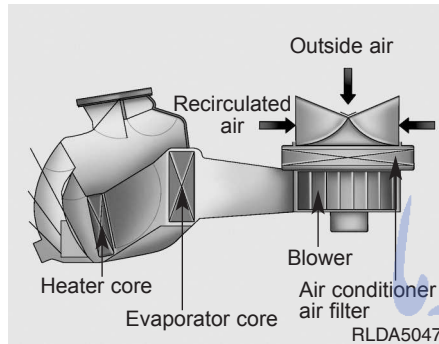

The air conditioner air filter installed behind the glove box filters the dust or other pollutants that come into the vehicle from the outside through the heating and air conditioning system. If dust or other pollutants accumulate in the filter over a period of time, the air flow from the air vents may decrease, resulting in moisture accumulation on the inside of the windshield even when the outside (fresh) air position is selected. If this happens, have the air conditioner air filter replaced by an Authorized Kia Dealer.

The air filter should be replaced every 15,000 km. If the vehicle is operated in the severely air-polluted cities or on dusty rough roads for a long period, it should be inspected more frequently and replaced earlier. When you try to replace the air filter by owner maintenance, replace it performing the following procedure, and in this case, be careful to avoid damaging other components.

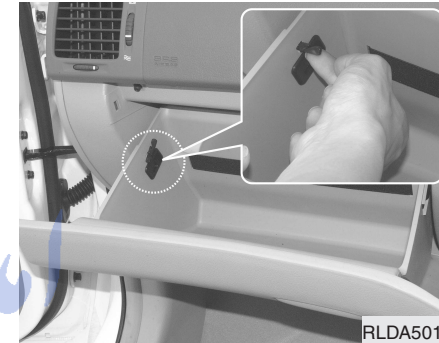

Filter replacement

1. Open the glove box part way, reach inside and pull out the elastic line and push the retaining clip through the hole on the side of the glove box. Allow the glove box to open.

1

2

3

4

5

6

7

8

9

- 1
- 2
- 3
- 4
- 5
- 6
- 7**
- 8
- 9

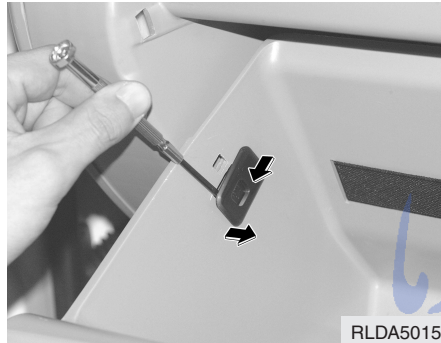

2. With the glove box open, remove the stoppers on both sides to allow the glove box hang freely on the hinges.

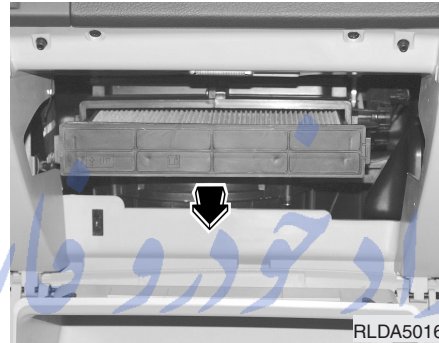

3. Pull out the hooks on both sides of the air conditioner air filter case.



4. Replace the air conditioner filter.
5. Reassemble in the reverse order of disassembly.

تلفن شبانه روزی: ۰۲۱-۸۸۸۶۲۰۸۵

*** NOTICE**

When replacing the air conditioner air filter install it according to the "AIR FLOW↓" and "↑UP" identification marks. Otherwise, the system may produce noise and the effectiveness of the filter may be reduced.

FarmaSOS.com

WIPER BLADES



Wiper blade maintenance

* NOTICE

Commercial hot waxes applied by automatic car washes have been known to make the windshield difficult to clean.

Contamination of either the windshield or the wiper blades with foreign matter can reduce the effectiveness of the windshield wipers. Common sources of contamination are insects, tree sap, and hot wax treatments used by some commercial car washes. If the blades are not wiping properly, clean both the window and the blades with a good cleaner or mild detergent, and rinse thoroughly with clean water.

* NOTICE

To prevent damage to the wiper blades, do not use gasoline, kerosene, paint thinner, or other solvents on or near them.

Windshield wiper blade replacement

When the wipers no longer clean adequately, the blades may be worn or cracked, and require replacement.

* NOTICE

To prevent damage to the wiper arms or other components, do not attempt to move the wipers manually.

* NOTICE

The use of a non-specified wiper blade could result in wiper malfunction and failure.

- 1
- 2
- 3
- 4
- 5
- 6
- 7
- 8
- 9

Maintenance

1



1. Raise the wiper arm and turn the wiper blade assembly to expose the plastic locking clip.

2

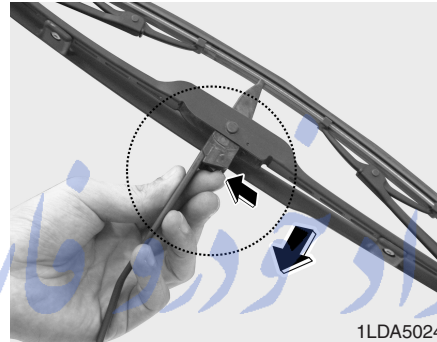

2. Compress the clip and slide the blade assembly downward.

3

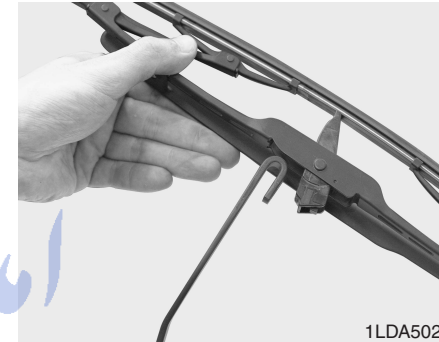

3. Lift it off the arm.

4

4. Install the blade assembly in the reverse order of removal.

5

6

* NOTICE

Do not allow the wiper arm to fall against the windshield.

7

8

9

تلفن شبانه روزی: ۰۲۱-۸۸۸۶۲۰۸۵

FarmaSOS.com

BATTERY**⚠ WARNING - Battery dangers**

Always read the following instructions carefully when handling a battery.



Keep lighted cigarettes and all other flames or sparks away from the battery.



Hydrogen, which is a highly combustible gas, is always present in battery cells and may explode if ignited.



Keep batteries out of the reach of children because batteries contain highly corrosive **SULFURIC ACID**. Do not allow battery acid to contact your skin, eyes, clothing or paint finish.

(Continued)

(Continued)



If any electrolyte gets into your eyes, flush your eyes with clean water for at least 15 minutes and get immediate medical attention. If possible, continue to apply water with a sponge or cloth until medical attention is received.

If electrolyte gets on your skin, thoroughly wash the contacted area. If you feel a pain or a burning sensation, get medical attention immediately.



Wear eye protection when charging or working near a battery. Always provide ventilation when working in an enclosed space.

(Continued)

(Continued)

- When lifting a plastic-cased battery, excessive pressure on the case may cause battery acid to leak, resulting in personal injury. Lift with a battery carrier or with your hands on opposite corners.
- Never attempt to charge the battery when the battery cables are connected.
- The electrical ignition system works with high voltage. Never touch these components with the engine running or the ignition switched on.

1

2

3

4

5

6

7

8

9

1

2

3

4

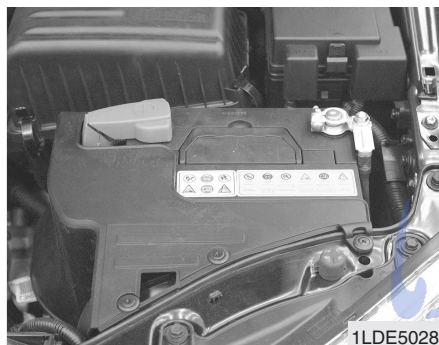

5

6

7

8

9

Battery recharging

Your vehicle has a maintenance-free, calcium-based battery.

- If the battery becomes discharged in a short time (because, for example, the headlights or interior lights were left on while the vehicle was not in use), recharge it by slow charging (trickle) for 10 hours.
- If the battery gradually discharges because of high electric load while the vehicle is being used, recharge it at 20-30A for two hours.

Items to be reset after the battery has been discharged or the battery has been disconnected.

- Clock (See page 3-95)
- Climate control system (See pages 4-57)
- Audio (See the audio manual)
- Sunroof (See page 3-96)

For best battery service :

- Keep the battery securely mounted.
- Keep the battery top clean and dry.
- Keep the terminals and connections clean, tight, and coated with petroleum jelly or terminal grease.
- Rinse any spilled electrolyte from the battery immediately with a solution of water and baking soda.
- If the vehicle is not going to be used for an extended time, disconnect the battery cables.

تلفن شبانه روزی: ۰۸۵-۸۸۶۲-۲۱

ArmaSOS.com

⚠ WARNING - Recharging battery

When recharging the battery, observe the following precautions:

- The battery must be removed from the vehicle and placed in an area with good ventilation.
- Do not allow cigarettes, sparks, or flame near the battery.
- Watch the battery during charging, and stop or reduce the charging rate if the battery cells begin gassing (boiling) violently or if the temperature of the electrolyte of any cell exceeds 49°C (120°F).
- Wear eye protection when checking the battery during charging.

(Continued)

(Continued)

- Disconnect the battery charger in the following order.

1. Turn off the battery charger main switch.
2. Unhook the negative clamp from the negative battery terminal.
3. Unhook the positive clamp from the positive battery terminal.

*** NOTICE**

- Before performing maintenance or recharging the battery, turn off all accessories and stop the engine.
- The negative battery cable must be removed first and installed last when the battery is disconnected.

1

2

3

4

5

6

7

8

9

تلفن شبانه روزی: ۰۸۵-۸۸۸۶۲-۱

PharmaSOS.com

TYRES AND WHEELS

Tyres care

For proper maintenance, safety, and maximum fuel economy, you must always maintain recommended tyre inflation pressures and stay within the load limits and weight distribution recommended for your vehicle.

1

2

3

Inflation pressures

All tyre pressures (including the spare) should be checked every day when the tyres are cold. "Cold Tyres" means the vehicle has not been driven for at least three hours or driven less than 1.6 km (one mile).

4

5

6

Recommended pressures must be maintained for the best ride, top vehicle handling, and minimum tyre wear.

7

8

9



All specifications (sizes and pressures) can be found on a label attached to the front driver's door sill.

⚠ WARNING

Severe underinflation (70 kPa (10 psi) or more) can lead to severe heat build-up, especially on hot days and when driving at high speed. This can potentially cause tread separation and other tyre irregularities to appear that can result in the loss of vehicle control leading to severe injury or death.

* NOTICE

- Warm tyres normally exceed recommended cold tyre pressures by 28 to 41 kPa (4 to 6 psi). Do not release air from warm tyres to adjust the pressure or the tyres will be underinflated.
- Underinflation results in excessive wear, poor handling, reduced fuel economy, and the possibility of blowouts from overheated tyres. Also, low tyre pressure can cause poor sealing of the tyre bead. If the tyre pressure is excessively low, wheel deformation and/or tyre separation is possible. So, keep your tyre pressures at the proper levels. If a tyre frequently needs refilling, have it checked by an Authorized Kia Dealer.

(Continued)

(Continued)

- **Overinflation produces a harsh ride, handling problems, excessive wear at the centre of the tyre tread, and a greater possibility of damage from road hazards.**
- **Be sure to reinstall the tyre inflation valve caps. Without the valve cap, dirt or moisture could get into the valve core and cause air leakage. If the cap have been lost, install new one as soon as possible.**

⚠ WARNING - Tyre Inflation
Overinflation or underinflation can reduce tyre life, adversely affect vehicle handling, and lead to sudden tyre failure. This could result in loss of vehicle control.

Tyre rotation

To equalize tread wear, it is recommended that the tyres be rotated every 12,000 km (7,500 miles) or sooner if irregular wear develops.

During rotation, check the tyres for correct balance.

When rotating tyres, check for uneven wear and damage. Abnormal wear is usually caused by incorrect tyre pressure, improper wheel alignment, out-of-balance wheels, severe braking or severe cornering. Look for bumps or bulges in the tread or side of tyre. Replace the tyre if you find either of these conditions. Replace the tyre also if you can see fabric or cord. After rotation, be sure to bring the front and rear tyre pressures to specification and check lug nut tightness.

Refer to Section 8, Specifications.

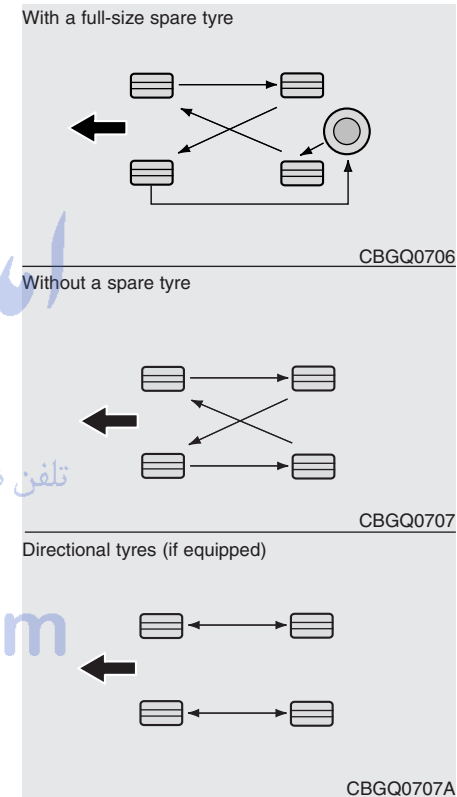

- 1
- 2
- 3
- 4
- 5
- 6
- 7
- 8
- 9

Disc brake pads and rear brake shoes should be inspected for wear whenever tyres are rotated.

1

*** NOTICE**

2

Rotate radial tyres that have an asymmetric tread pattern only from front to rear and not from right to left.

3

4

5

6

7

8

9

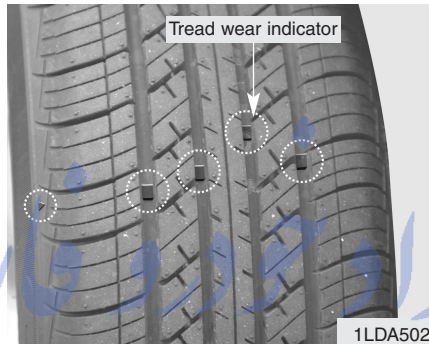

Tyre replacement

If the tyre is worn evenly, a tread wear indicator will appear as a solid band across the tread. This shows there is less than 1.6 mm (1/16 inch) of tread left on the tyre. Replace the tyre when this happens.

Do not wait for the band to appear across the entire tread before replacing the tyre.

Wheel alignment and tyre balance

The wheels on your vehicle were aligned and balanced carefully at the factory to give you the longest tyre life and best overall performance.

In most cases, you will not need to have your wheels aligned again. However, if you notice unusual tyre wear or your vehicle pulling one way or the other, the alignment may need to be reset.

If you notice your vehicle vibrating when driving on a smooth road, your wheels may need to be rebalanced.

*** NOTICE**

Improper wheel weights can damage your vehicle's aluminum wheels. Use only approved wheel weights.

⚠ WARNING

- When replacing tyres, never mix radial, bias-belted, and bias-type tyres. All four tyres should be of the same size, design and construction. Use only the tyre sizes listed on the Tyre Label found below the door striker on the driver's side. Make sure that all tyres and wheels are the same size and have the same load-carrying capacity. Use only tyre and wheel combinations recommended on the Tyre Label or by an Authorized Kia Dealer. Failure to follow these precautions can adversely affect the safety and handling of your vehicle.

(Continued)

(Continued)

- The use of any other tyre size or type may seriously affect ride, handling, ground clearance, tyre clearance, and speedometer calibration.
- Driving on worn-out tyres is very hazardous and will reduce braking effectiveness, steering accuracy, and traction.
- It is best to replace all four tyres at the same time. If that is not possible, or necessary, then replace the two front or two rear tyres as a pair. Replacing just one tyre can seriously affect your vehicle's handling.

Wheel replacement

When replacing the metal wheels for any reason, make sure the new wheels are equivalent to the original factory units in diameter, rim width and offset.

⚠ WARNING

A wheel that is not the correct size may adversely affect wheel and bearing life, braking and stopping abilities, handling characteristics, ground clearance, body-to-tyre clearance, snow chain clearance, speedometer calibration, headlight aim and bumper height.

- 1
- 2
- 3
- 4
- 5
- 6
- 7
- 8
- 9

PharmaSOS.com

- 1
- 2
- 3
- 4
- 5
- 6
- 7
- 8
- 9



Tyre size designation

A tyre's sidewall is marked with a tyre size designation. You will need this information when selecting replacement tyres for your car. The following explains what the letters and numbers in the tyre size designation mean.

Example tyre size designation:

195/60 R15 88H

(These numbers are provided as an example only; your tyre size designator could vary depending on your vehicle.)

- 195 - Tyre width in millimeters.
- 60 - Aspect ratio. The tyre's section height as a percentage of its width.
- R - Tyre construction code (Radial).
- 15 - Rim diameter in inches.
- 88 - Load Index, a numerical code associated with the maximum load the tyre can carry.
- H - Speed Rating Symbol. See the speed rating chart in this section for additional information.

Wheel size designation

Wheels are also marked with important information that you need if you ever have to replace one. The following explains what the letters and numbers in the wheel size designation mean.

Example wheel size designation:

6.0 J x 15

- 6.0 - Rim width in inches.
- J - Rim contour designation.
- 15 - Rim diameter in inches.

Tyre speed ratings

The chart below shows many of the different speed ratings currently being used for passenger car. The speed rating symbol is part of the tyre size designation on the sidewall of the tyre. This symbol corresponds to that tyre's designed maximum safe operating speed.

Speed Rating Symbol	Maximum Speed
S	180 km/h (112 mph)
T	190 km/h (118 mph)
H	210 km/h (130 mph)
V	240 km/h (149 mph)
Z	Above 240 km/h (149 mph)



Uniform tyre quality grading

Tread wear

The tread wear grade is a comparative rating based on the wear rate of the tyre when tested under controlled conditions on a specified government test course. For example, a tyre graded 150 would wear one-and-a-half times as well on the government test course as a tyre graded 100.

The relative performance of tyres depends upon the actual conditions of their use. However, performance may differ from the norm because of variations in driving habits, service practices and differences in road characteristics and climate.

These grades are molded on the side-walls of passenger vehicle tyres. The tyres available as standard or optional equipment on Kia vehicles may vary with respect to grade.

Traction - A, B & C

The traction grades, from highest to lowest, are A, B and C. The grades represent the tyre's ability to stop on wet pavement as measured under controlled conditions on specified government test surfaces of asphalt and concrete. A tyre marked C may have poor traction performance.

Temperature -A, B & C

The temperature grades are A (the highest), B and C. The grades represent the tyre's resistance to the generation of heat and its ability to dissipate heat when tested under controlled conditions on a specified indoor laboratory test wheel.

Sustained high temperature can cause the material of the tyres to degenerate and reduce tyre life, and excessive temperature can lead to sudden tyre failure. Grades A and B represent higher levels of performance on the laboratory test wheel than the minimum required by the law.

1

2

3

4

5

6

7

8

9

- 1
- 2
- 3
- 4
- 5
- 6
- 7**
- 8
- 9

⚠ WARNING - Tyre temperature
The temperature grade for this tyre is established for a tyre that is properly inflated and not overloaded. Excessive speed, underinflation, or excessive loading, either separately or in combination, can cause heat build-up and possible sudden tyres failure. This can cause loss of vehicle control and serious injury or death.



Checking a tyre life

Tyre strength and performance decline with age. Any tyres that are over 6 year old, including the spare (determined by the tyre manufacture date), should be replaced regardless of mileage. You can find the tyre manufacture date on the tyre sidewall (either on the inside or outside of the wheel). The date is a Department Of Transportation (DOT) number consisting of letters and numbers. You can determine the tyre manufacture date by the last four numbers of the DOT code.

DOT : XXXX XXXX 0000
The first letters/numbers of the DOT indicate the manufacturing plant, tyre size and tread pattern, last four numbers indicate week and year manufactured.
For example:
DOT XXXX XXXX 0803 represents that the tyre was produced in the 8th week of 2003.

⚠ WARNING
A tyre more than 6 years old may cause separation of the cord layers inside the tyre leading to loss of vehicle or a serious injury. Therefore, make sure to check the manufacturing date and replace the old tyre in 6 years after the tyre manufacturing date.

BULB REPLACEMENT**⚠ WARNING - Working on the lights**

Prior to working on the light, firmly apply the parking brake, ensure that the ignition switch is turned to the "LOCK" position and turn off the lights to avoid sudden movement of the vehicle and burning your fingers or receiving an electric shock.

Use only the bulbs of the specified wattage.

*** NOTICE**

If you don't have necessary tools, the correct bulbs and the expertise, consult an Authorized Kia Dealer. In many cases, it is difficult to replace vehicle light bulbs because other parts of the vehicle must be removed before you can get to the bulb. This is especially true if you have to remove the front bumper to get to the bulb(s).

Removing/installing the front bumper or bumper hardware can result in damage to the vehicle.

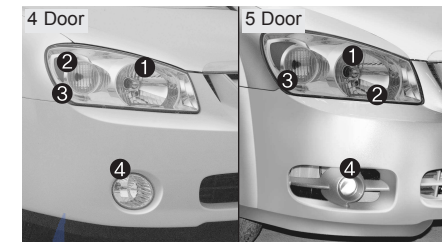

- ① Headlight (High/Low)
- ② Position light
- ③ Front turn signal light
- ④ Front fog light (if equipped)

1LDN5032/1LDE5032

Headlight bulb replacement*** NOTICE**

After heavy, driving rain or washing, headlight and taillight lenses could appear frosty. This condition is caused by the temperature difference between the lamp inside and outside. This is similar to the condensation on your windows inside your vehicle during the rain and doesn't indicate a problem with your vehicle. If the water leaks into the lamp bulb circuitry, have the vehicle checked by an Authorized Kia Dealer.

1

2

3

4

5

6

7

8

9

تلفن شبانه روزی: ۰۲۱-۸۸۸۶۲۰۸۵

FarmaSOS.com

1

2

3

4

5

6

7

8

9



(Continued)

- If a bulb becomes damaged or cracked, replace it immediately and carefully dispose of it.
- Wear eye protection when changing a bulb. Allow the bulb to cool down before handling it.

⚠ WARNING - Halogen bulbs

- Halogen bulbs contain pressurized gas that will produce flying pieces of glass if broken.
- Always handle them carefully, and avoid scratches and abrasions. If the bulbs are lit, avoid contact with liquids. Never touch the glass with bare hands. Residual oil may cause the bulb to overheat and burst when lit. A bulb should be operated only when installed in a headlight.

(Continued)

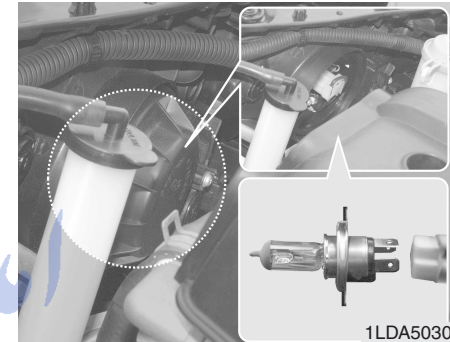

1. Open the hood.
2. Remove the headlight bulb cover by turning it counterclockwise.
3. Disconnect the headlight bulb socket-connector.
4. Unsnap the headlight bulb retaining wire by depressing the end and pushing it upward.
5. Remove the bulb from the headlight assembly.

6. Install a new headlight bulb and snap the headlight bulb retaining wire into position by aligning the wire with the groove on the bulb.
7. Connect the headlight bulb socket-connector.
8. Install the headlight bulb cover by turning it clockwise.



Front turn signal/position light bulb replacement

1. Open the hood.
2. Remove the socket from the assembly by turning the socket counterclockwise until the tabs on the socket align with the slots on the assembly.
3. Remove the bulb from the socket by pressing it in and rotating it until the tabs on the bulb align with the slots in the socket. Pull the bulb out of the socket.
4. Insert a new bulb by inserting it into the socket and rotating it until it locks into place.

5. Install the socket in the assembly by aligning the tabs on the socket with the slots in the assembly. Insert the socket into the assembly and turn the socket clockwise.

Front fog light bulb replacement

If the light bulb is not operating, have the vehicle checked by an authorized Kia Dealer.

1

2

3

4

5

6

7

8

9

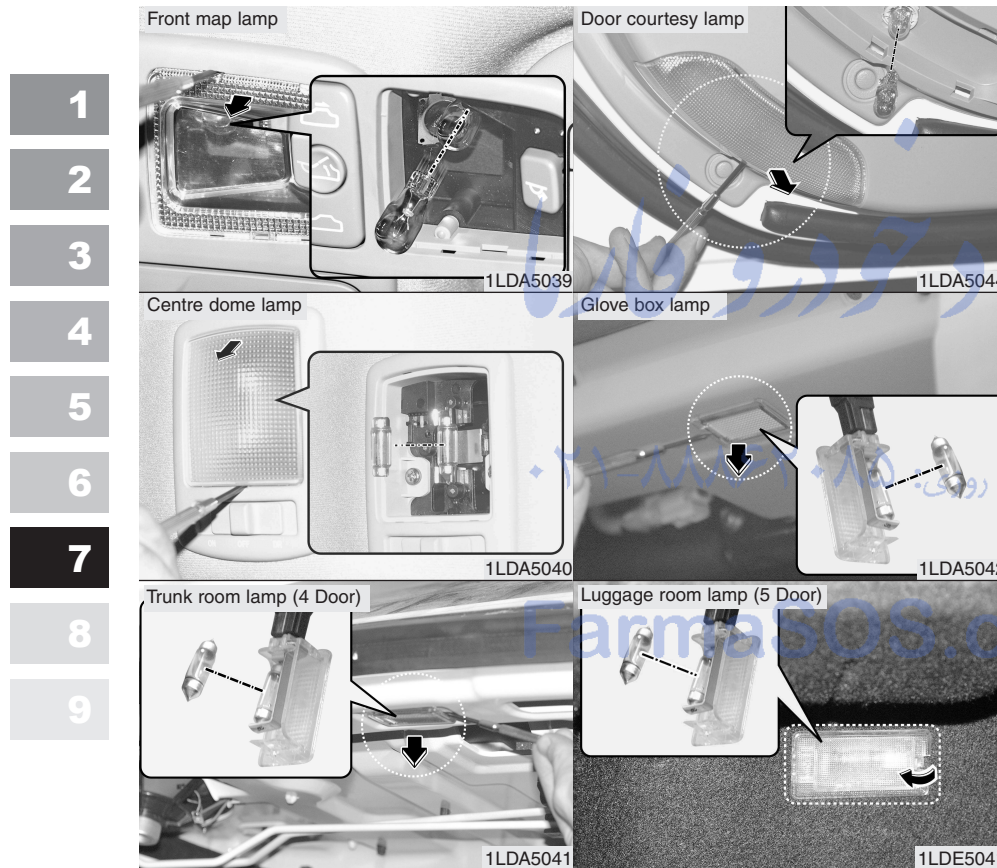

Interior lights bulb replacement

1. Using a flat-blade screwdriver, gently pry the lens from the interior light housing.

CAUTION

Prior to working on the Interior Lights, ensure that the "OFF" button is depressed to avoid burning your fingers or receiving an electric shock.

2. Remove the bulb by pulling it straight out.
3. Install a new bulb in the socket.
4. Align the lens tabs with the interior light housing notches and snap the lens into place.

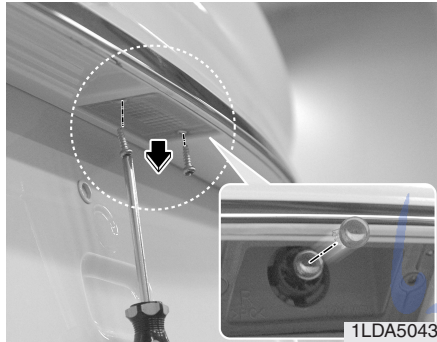

License plate lights bulb replacement

1. Loosen the lens retaining screws with a cross-tip screwdriver.
2. Remove the lens.
3. Remove the bulb by pulling it straight out.
4. Install a new bulb.
5. Reinstall the lens securely with the lens retaining screws.



Rear combination light bulb replacement

1. Open the trunk lid or rear hatch.

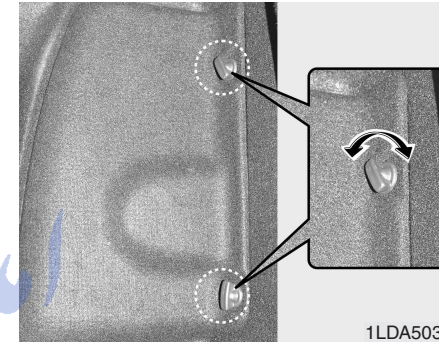

2. Remove the service cover by turning the plastic screw counterclockwise and removing the cover.

- 1
- 2
- 3
- 4
- 5
- 6
- 7
- 8
- 9

- 1
- 2
- 3
- 4
- 5
- 6
- 7
- 8
- 9

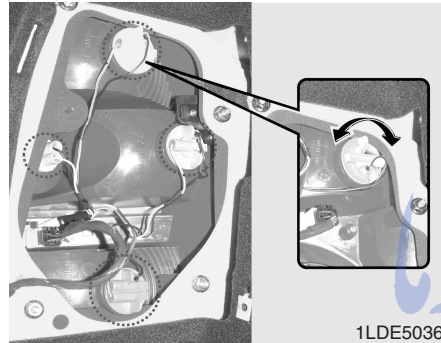

3. Remove the socket from the assembly by turning the socket counterclockwise until the tabs on the socket align with the slots on the assembly.

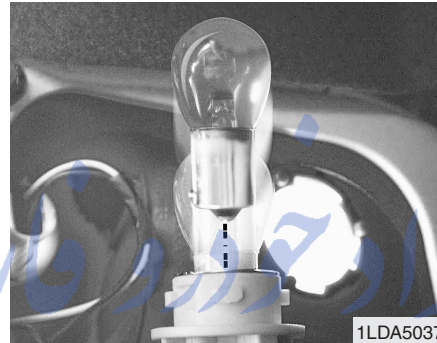

4. Remove the bulb from the socket by pressing it in and rotating it until the tabs on the bulb align with the slots in the socket. Pull the bulb out of the socket.

5. Insert a new bulb by inserting it into the socket and rotating it until it locks into place.

6. Install the socket in the assembly by aligning the tabs on the socket with the slots in the assembly. Push the socket into the assembly and turn the socket clockwise.

7. Replace the service cover and tighten the screws.

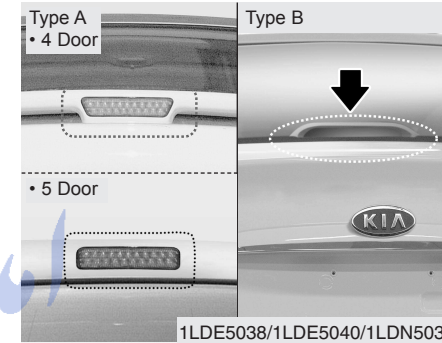

High mounted stop light bulb replacement

Type A

If the light bulb is not operating, have the vehicle checked by an authorized Kia Dealer.

Type B

1. Open the trunk lid.

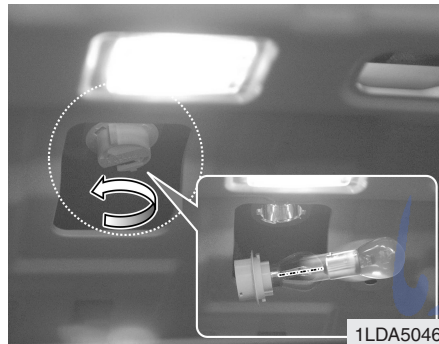

2. Remove the socket from the housing by turning the socket counter-clockwise until the tabs on the socket align with the slots on the housing.
3. Remove the bulb from the socket by pressing it in and rotating it until the tabs on the bulb align with the slots in the socket. Pull the bulb out of the socket.
4. Insert a new bulb by inserting it into the socket and rotating it until it locks into place.
5. Install the socket in the housing by aligning the tabs on the socket with the slots in the housing. Insert the socket into the housing and turn the socket clockwise.

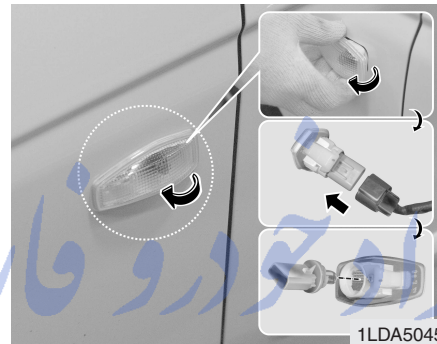

Side repeater light bulb replacement (if equipped)

1. Remove the light assembly from the vehicle by pushing the lens forward and pulling the assembly out.
2. Disconnect the bulb electrical connector.
3. Separate the socket and the lens parts by turning the socket counter-clockwise until the tabs on the socket align with the slots on the lens part.

4. Remove the bulb by pulling it straight out.
5. Insert a new bulb in the socket.
6. Reassemble the socket and the lens part.
7. Connect the bulb electrical connector.
8. Reinstall the light assembly to the body of the vehicle.

- 1
- 2
- 3
- 4
- 5
- 6
- 7
- 8
- 9

LUBRICANT SPECIFICATIONS

Recommended lubricants

To help achieve proper engine and powertrain performance and durability, use only lubricants of the proper quality. The correct lubricants also help promote engine efficiency that results in improved fuel economy.

Engine oils labeled Energy Conserving Oil are now available. Along with other additional benefits, they contribute to fuel economy by reducing the amount of fuel necessary to overcome engine friction. Often, these improvements are difficult to measure in everyday driving, but in a year's time, they can offer significant cost and energy savings.

Recommended SAE viscosity number

* NOTICE

Always be sure to clean the area around any filler plug, drain plug, or dipstick before checking or draining any lubricant. This is especially important in dusty or sandy areas and when the vehicle is used on unpaved roads. Cleaning the plug and dipstick areas will prevent dirt and grit from entering the engine and other mechanisms that could be damaged.

1

2

3

4

These lubricants and fluids are recommended for use in your vehicle.

Lubricant		Classification	
Engine oil *1	Gasoline Engine	API Service SJ, SL or above, ILSAC GF-3 or above	
	Diesel Engine	1.5L	API Service CH-4 or above, ACEA B4 or above
		2.0L	API Service CF-4 or above, ACEA B4 or above
Manual transaxle fluid		API Service GL-4 (SAE 75W-85, fill-for-life)	
Automatic transaxle fluid		DIAMOND ATF SP-III or SK ATF SP-III	
Power steering fluid		PSF-III	
Brake/Clutch fluid		FMVSS116 DOT-3 or DOT-4	

*1 Refer to the recommended SAE viscosity numbers on the next page.

7

8

9

Engine oil viscosity (thickness) has an effect on fuel economy and cold weather operating (starting and oil flow). Lower viscosity engine oils can provide better fuel economy and cold weather performance, however, higher viscosity engine oils are required for satisfactory lubrication in hot weather. Using oils of any viscosity other than those recommended could result in engine damage. When choosing an oil, consider the range of temperature your vehicle will be operated in before the next oil change. Proceed to select the recommended oil viscosity from the chart.

		Temperature Range for SAE Viscosity Numbers									
Temperature	°C	-30	-20	-10	0	10	20	30	40	50	
	(°F)	-10	0	20	40	60	80	100	120		
Gasoline Engine Oil *1		20W-50									
		15W-40									
		10W-30									
		5W-20, 5W-30									
Diesel Engine Oil		30									
		20W-40									
		15W-40									
		10W-30									
		5W-30									
		0W-30 *2									

1. For better fuel economy, it is recommended to use the engine oil of a viscosity grade SAE 5W-20,5W-30 (API SJ, SL / ILSAC GF-3). However, the engine oil is not available in your country, select the proper engine oil using the engine oil viscosity chart.
2. It is only for extreme cold area and to be restricted by driving condition and area. (Especially, not recommended for sustained high loaded and high speed operation.)

FarmaSOS.com



EXTERIOR CARE

Exterior general caution

It is very important to follow the label directions when using any chemical cleaner or polish. Read all warning and caution statements that appear on the label.

1

2

Finish maintenance

Washing

To help protect your vehicle's finish from rust and deterioration, wash it thoroughly and frequently at least once a month with lukewarm or cold water.

4

5

6

7

If you use your vehicle for off-road driving, you should wash it after each off-road trip. Pay special attention to the removal of any accumulation of salt, dirt, mud, and other foreign materials. Make sure the drain holes in the lower edges of the doors and rocker panels are kept clear and clean.

8

9

Insects, tar, tree sap, bird droppings, industrial pollution and similar deposits can damage your vehicle's finish if not removed immediately.

Even prompt washing with plain water may not completely remove all these deposits. A mild soap, safe for use on painted surfaces, may be used.

After washing, rinse the vehicle thoroughly with lukewarm or cold water. Do not allow soap to dry on the finish.

* NOTICE

Do not use strong soap, chemical detergents or hot water, and do not wash the vehicle in direct sunlight or when the body of the vehicle is warm.

⚠ WARNING

After washing the vehicle, test the brakes while driving slowly to see if they have been affected by water. If braking performance is impaired, dry the brakes by applying them lightly while maintaining a slow forward speed.

⚠ CAUTION

- *Water washing in the engine compartment may cause the failure of electrical circuits located in the engine compartment.*
- *Pay extreme attention to wash the engine compartment by using water.*

Waxing

Wax the vehicle when water will no longer bead on the paint.

Always wash and dry the vehicle before waxing. Use a good quality liquid or paste wax, and follow the manufacturer's instructions. Wax all metal trim to protect it and to maintain its luster.

Removing oil, tar, and similar materials with a spot remover will usually strip the wax from the finish. Be sure to re-wax these areas even if the rest of the vehicle does not yet need waxing.

*** NOTICE**

- Wiping dust or dirt off the body with a dry cloth will scratch the finish.
- Do not use steel wool, abrasive cleaners, or strong detergents containing highly alkaline or caustic agents on chrome-plated or anodized aluminum parts. This may result in damage to the protective coating and cause discoloration or paint deterioration.

Finish damage repair

Deep scratches or stone chips in the painted surface must be repaired promptly. Exposed metal will quickly rust and may develop into a major repair expense.

*** NOTICE**

If your vehicle is damaged and requires any metal repair or replacement, be sure the body shop applies anti-corrosion materials to the parts repaired or replaced.

1

2

3

4

5

6

7

8

9

تلفن شبانه روزی: ۰۲۱-۸۸۸۶۲۰۸۵

FarmaSOS.com

1

Bright-metal maintenance

- To remove road tar and insects, use a tar remover, not a scraper or other sharp object.
- To protect the surfaces of bright-metal parts from corrosion, apply a coating of wax or chrome preservative and rub to a high luster.
- During winter weather or in coastal areas, cover the bright metal parts with a heavier coating of wax or preservative. If necessary, coat the parts with non-corrosive petroleum jelly or other protective compound.

2

3

4

5

6

7

8

9

Underbody maintenance

Corrosive materials used for ice and snow removal and dust control may collect on the underbody. If these materials are not removed, accelerated rusting can occur on underbody parts such as the fuel lines, frame, floor pan and exhaust system, even though they have been treated with rust protection.

Thoroughly flush the vehicle underbody and wheel openings with lukewarm or cold water once a month, after off-road driving and at the end of each winter. Pay special attention to these areas because it is difficult to see all the mud and dirt. It will do more harm than good to wet down the road grime without removing it. The lower edges of doors, rocker panels, and frame members have drain holes that should not be allowed to clog with dirt; trapped water in these areas can cause rusting.

⚠ WARNING

After washing the vehicle, test the brakes while driving slowly to see if they have been affected by water. If braking performance is impaired, dry the brakes by applying them lightly while maintaining a slow forward speed.

Aluminum wheel maintenance

The aluminum wheels are coated with a clear protective finish.

- Do not use any abrasive cleaner, polishing compound, solvent, or wire brushes on aluminum wheels. They may scratch or damage the finish.
- Use only a mild soap or neutral detergent, and rinse thoroughly with water. Also, be sure to clean the wheels after driving on salted roads. This helps prevent corrosion.
- Avoid washing the wheels with high-speed car wash brushes.
- Do not use any acid detergent. It may damage and corrode the aluminum wheels coated with a clear protective finish.

FarmaSOS.com

1

2

3

4

5

6

7

8

9

INTERIOR CARE

Interior general precautions

1

Prevent caustic solutions such as perfume and cosmetic oil from contacting the dashboard because they may cause damage or discoloration. If they do contact the dashboard, wipe them off immediately. See the instructions that follow for the proper way to clean vinyl.

2

3

4

Cleaning the upholstery and interior trim

5

Vinyl

Remove dust and loose dirt from vinyl with a whisk broom or vacuum cleaner. Clean vinyl surfaces with a vinyl cleaner.

6

7

8

9

Fabric

Remove dust and loose dirt from fabric with a whisk broom or vacuum cleaner. Clean with a mild soap solution recommended for upholstery or carpets. Remove fresh spots immediately with a fabric spot cleaner. If fresh spots do not receive immediate attention, the fabric can be stained and its colour can be affected. Also, its fire-resistant properties can be reduced if the material is not properly maintained.

CAUTION

Using anything but recommended cleaners and procedures may affect the fabric's appearance and fire-resistant properties.

Cleaning the lap/shoulder belt webbing

Clean the belt webbing with any mild soap solution recommended for cleaning upholstery or carpet. Follow the instructions provided with the soap. Do not bleach or re-dye the webbing because this may weaken it.

Cleaning the interior window glass

If the interior glass surfaces of the vehicle become fogged (that is, covered with an oily, greasy or waxy film), they should be cleaned with glass cleaner. Follow the directions on the glass cleaner container.

*** NOTICE**

Do not scrape or scratch the inside of the rear window. This may result in damage to the rear window defroster grid.

<p>امداد خودرو فارما</p> <p>تلفن شبانه روزی: ۰۲۱-۸۸۸۶۲۰۸۵</p> <p>Farma</p>	Specifications / 8-2	1
		2
		3
		4
		5
		6
		7
	Specifications	8
		9

Specifications

SPECIFICATIONS

The specifications given here are for general information only. Please check with an authorized Kia dealer for more precise and more up-to-date information.

1

Dimensions

mm (in)

Item	4 Door	5 Door
Overall length	4,480 (176.4)	4,340 (170.9)
Overall width	1,735 (68.3)	1,735 (68.3)
Overall height	1,470 (57.9)	1,470 (57.9)
Front tread	1,495 (58.9)	1,495 (58.9)
Rear tread	1,485 (58.5)	1,485 (58.5)
Wheelbase	2,610 (102.8)	2,610 (102.8)

2

3

4

5

Tyres

Item	Tyre size	Wheel size	Inflation pressure: تلفن شبانه روزی: ۰۲۱-۸۸۸۶۲۰۸۸				Wheel lug nut torque kg•m (lb•ft, N•m)
			bar (psi, kPa)				
			Normal load *1		Maximum load		
			Front	Rear	Front	Rear	
European model	185/65R15 88H	6.0Jx15	2.1	2.1	2.1	2.2	9~11 (65~79, 88~107)
	195/60R15 88H	6.0Jx15	(30, 210)	(30, 210)	(30, 210)	(32, 220)	
	205/50R16 87V	6.0Jx16					
Except European model	185/65R15 88H	6.0Jx15	2.1	2.1	2.1	2.1	
	195/60R15 88H	6.0Jx15	(30, 210)	(30, 210)	(30, 210)	(30, 210)	
	205/50R16 87V	6.0Jx16					

*1 Normal load : Up to 4 persons

Capacities

Lubricant		Volume	Classification
Engine oil *1 (with filter change)	Gasoline Engine	1.6L	3.3 l (3.5 US qt.)
		2.0L	4.0 l (4.2 US qt.)
	Diesel Engine	1.5L	5.3 l (5.6 US qt.)
		2.0L	5.9 l (6.2 US qt.)
Manual transaxle fluid	Gasoline Engine	2.15 l (2.27 US qt.)	API Service GL-4 SAE 75W-85 (fill for-life)
	Diesel Engine	2.10 l (2.22 US qt.)	
Automatic transaxle fluid		7.8 l (8.2 US qt.)	DIAMOND ATF SP-III, SK ATF SP-III
Power steering		0.8 l (0.8 US qt.)	PSF-III
Coolant		8.14 l (8.6 US qt.)	Ethylene glycol base for aluminum radiator
Brake/Clutch fluid		0.7~0.8 l (0.7~0.8 US qt.)	FMVSS116 DOT-3 or DOT-4
Fuel		55 l (14.5 US gal)	-

*1 Refer to the recommended SAE viscosity numbers on the page 7-61.



Specifications

Light bulbs

Wattage

	Light Bulb	4 Door	5 Door
1	Headlights (Low/High)	55/60	55/60
	Front turn signal lights	21	21
2	Position lights	5	5
	Side repeater lights (if equipped)	5	5
3	Front fog lights (if equipped)	Gasoline Engine	27
		Diesel Engine	51
4	Stop and tail lights	For Europe	21/5
		Except Europe	28/8
	Rear turn signal lights	21	21
5	Back-up lights	16	16
	Rear fog lights (if equipped)	21	21
6	High mounted stop light	21 or LED*1	LED*1
	License plate lights	5	5
7	Front map lamp	10	10
	Centre dome lamp	10	10
8	Door courtesy lamps	5	5
	Trunk room lamp	5	5
9	Glove box lamp	5	5

*1 LED : Light-emitting diode

امداد خودرو فارما

تلفن شبانه روزی: ۰۲۱-۸۸۸۶۲۰۸۵

FarmaSOS.com

1

2

3

4

5

6

7

8

Index

9

Index

	A		Emission control system5-3
	Air cleaner7-37		Engine compartment7-16
1	Air conditioner air filter.....7-39		Engine cooling system7-22
	Airbags-supplemental restraint system3-56		Engine oil and oil filter.....7-19
	Antenna.....3-100		Exterior care.....7-62
2	Automatic climate control system4-66		Exterior overview.....2-2
	Automatic transaxle4-8, 7-32		
	B	F	
3	Battery.....7-43		Fuel filler lid3-79
	Before driving.....5-5		Fuel filter7-36
4	Brake system4-15		Fuel requirements5-2
	Brakes and clutch7-25	G	
5	Bulb replacement7-53		Gauges.....4-34
	C	H	
6	Cruise control system4-25		Hazard warning flasher4-56
	D		Hood3-77
7	Defroster4-55		How to use this manual1-2
	Door locks3-8	I	
8	Drive belts.....7-27		If you have a flat tyre6-19
	E		Ignition switch4-2
9	Electrical circuit protection6-7		Immobilizer system.....3-7
	Emergency starting.....6-4		Instrument cluster4-33
			Instrument panel overview2-5
			Interior care.....7-66

Interior features	3-91
Interior lights	3-86
Interior overview	2-4

K

Keys	3-2
------------	-----

L

Label information	5-23
Lighting	4-46
Loading your vehicle	5-22
Lubricant specifications	7-60
Lubricants and fluids	7-35
Luggage net	3-99

M

Maintenance services	7-3
Maintenance under severe usage conditions	7-11
Manual climate control system	4-57
Manual transaxle	4-7, 7-30
Mirrors	3-82

N

Normal maintenance schedule	7-5
-----------------------------------	-----

O

Overheating	6-3
Overloading	5-21
Owner maintenance	7-13

P

Parking brake	7-26
Power steering	7-28

R

Remote keyless entry	3-4
Road warning	6-2

S

Safety belts	3-30
Seats	3-16
Special driving conditions	5-7
Specifications	8-2
Starting the engine	4-4
Steering wheel	4-22, 7-29
Storage compartment	3-88
Suggestions for economical operation	5-6
Sunroof	3-96

1

2

3

4

5

6

7

8

9

Index

T

	Theft-alarm system	4-84
	Towing	6-14
1	Traction control system	4-30
	Trailer towing	5-13
2	Trunk	3-75
	Tyres and wheels	7-46

V

3	Vehicle break-in process	1-3
---	--------------------------	-----

W

4	Warnings and indicators	4-38
5	Windows	3-13
6	Windshield defrosting and defogging	4-79
7	Wiper blades	7-41
	Wipers and washers	4-52